









APPENDIX

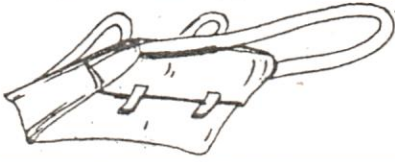

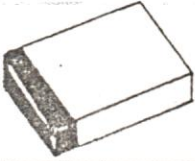

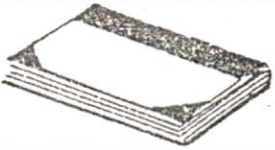



(१) क्या छात्र दैनिक जीवन में काम आने वाली वस्तु को पहचान रहा है ?

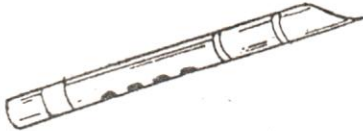

वस्तुएं	उत्तर
(क) 	हाँ / नहीं
(ख) 	हाँ / नहीं
(ग) 	हाँ / नहीं
(घ) 	हाँ / नहीं
(ङ) 	हाँ / नहीं
(च) 	हाँ / नहीं
(छ) 	हाँ / नहीं
(ज) 	हाँ / नहीं

Identify

(२) क्या छात्र चित्रों को देखकर पहचान सकता है?







चित्र	उत्तर
(क) 	हाँ / नहीं
(ख) 	हाँ / नहीं
(ग) 	हाँ / नहीं
(घ) 	हाँ / नहीं
(ङ) 	हाँ / नहीं
(च) 	हाँ / नहीं
(छ) 	हाँ / नहीं
(ज) 	हाँ / नहीं

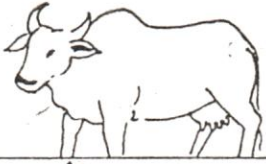

Identify 7

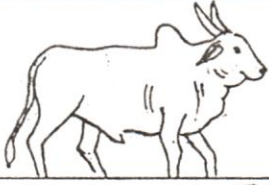

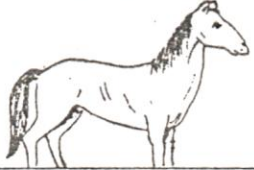
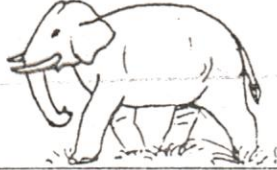
(३) क्या छात्र चित्रों को देखकर पशु और पक्षी को पहचान सकते हैं ?

पशु-पक्षी	उत्तर
(क) 	पशु / पक्षी
(ख) 	पशु / पक्षी
(ग) 	पशु / पक्षी
(घ) 	पशु / पक्षी
(ङ) 	पशु / पक्षी
(च) 	पशु / पक्षी
(छ) 	पशु / पक्षी
(ज) 	पशु / पक्षी

Disturbed पशु - पक्षी



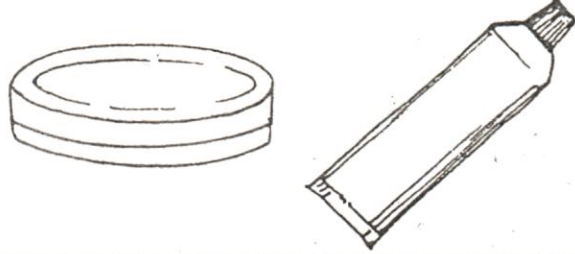
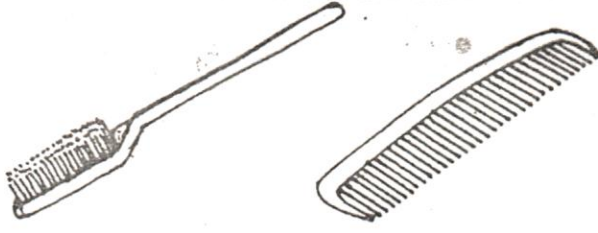
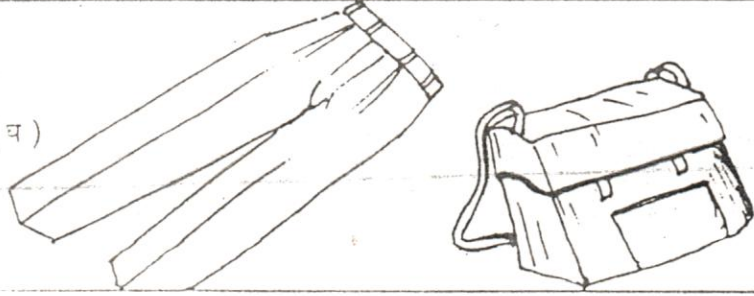
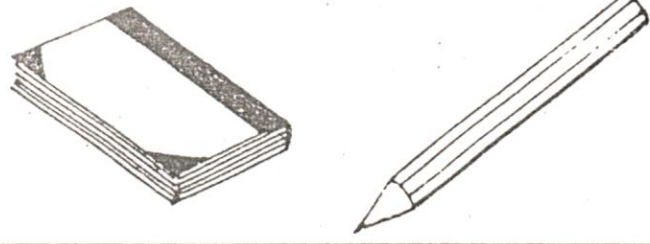



(४) क्या छात्र परिचित वस्तुओं को छाँटकर अलग कर सकते हैं?

	वस्तुएं	उत्तर
(क)		हाँ / नहीं
(ख)		हाँ / नहीं
(ग)		हाँ / नहीं
(घ)		हाँ / नहीं
(ङ)		हाँ / नहीं



Disson

(५) क्या छात्र सब्जी और फलों को पहचान रहे हैं? इनमें कौन से फल सब्जी के रूप में भी प्रयोग में लाये जाते हैं?

फल-सब्जी	उत्तर
(क) 	फल / सब्जी
(ख) 	फल / सब्जी
(ग) 	फल / सब्जी
(घ) 	फल / सब्जी
(ङ) 	फल / सब्जी
(च) 	फल / सब्जी
(छ) 	फल / सब्जी



clarif

(६) किसी चार्ट को देखकर छात्र घटना का वर्णन कैसे और कितना करते हैं?

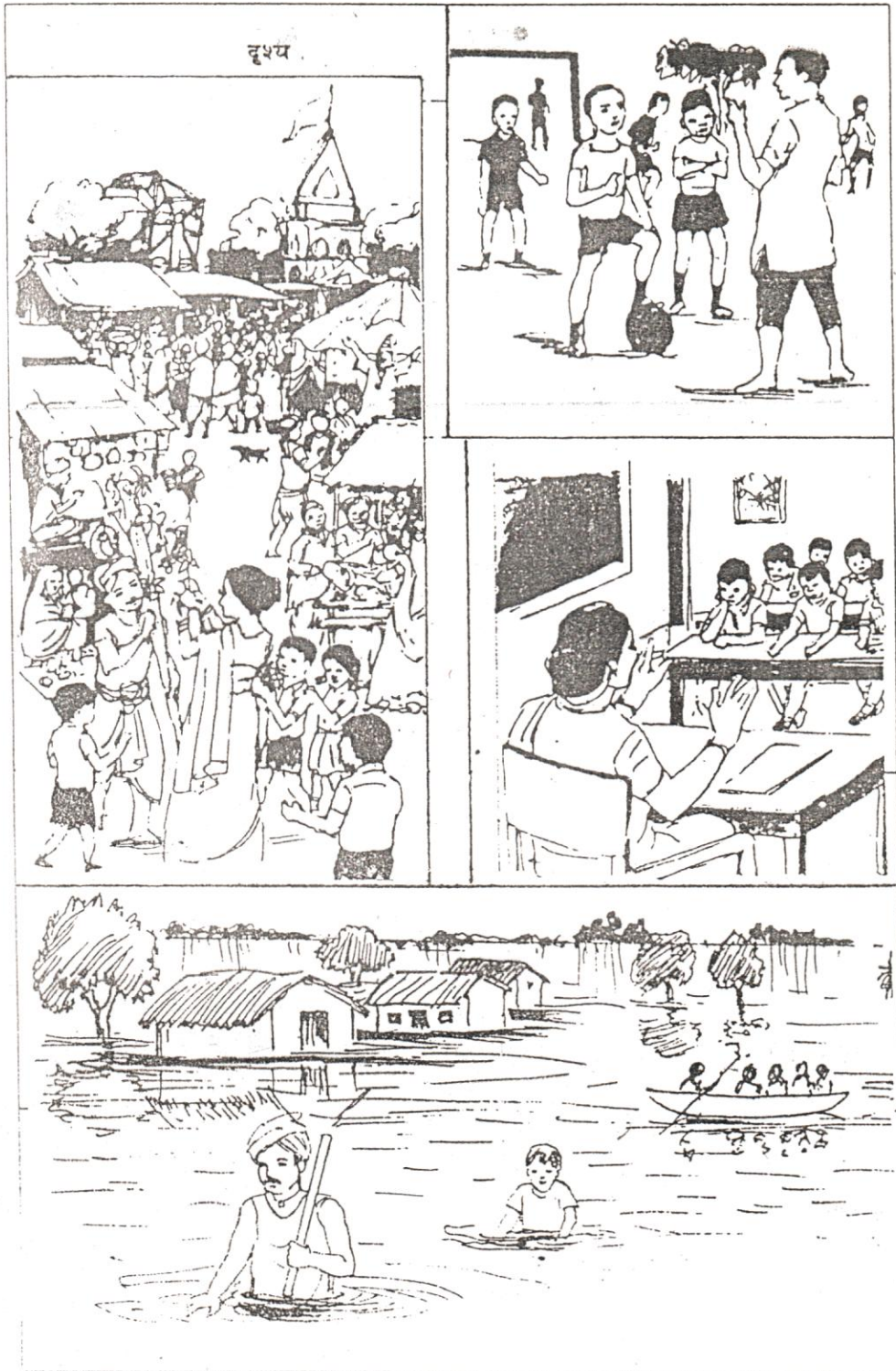

Imagines

(७) क्या छात्र फ्लैश कार्ड से कोई कहानी बता सकते हैं?



फ्लैश कार्ड	उत्तर
(क)	हाँ / नहीं
(ख)	हाँ / नहीं
(ग)	हाँ / नहीं
(घ)	हाँ / नहीं
(ङ)	हाँ / नहीं

Image

(८) क्या छात्र एक आकृति को देखकर दूसरी आकृति का मिलान कर सकते हैं ?

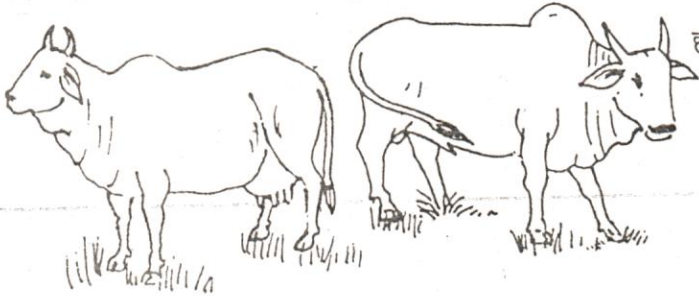
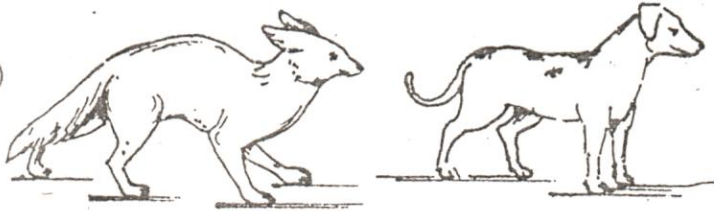
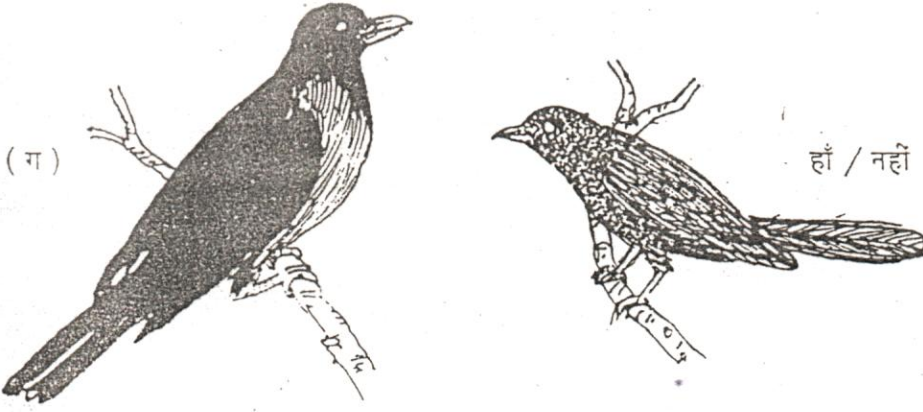

आकृति	उत्तर
<p>(क)</p> 	हाँ / नहीं
<p>(ख)</p> 	हाँ / नहीं
<p>(ग)</p> 	हाँ / नहीं

Match

(६) क्या छात्र किमी कहानी के चित्रों को फाइकर उमे क्रमवार लगा सकते हैं ?



कहानी	उत्तर
(क)	हाँ / नहीं
(ख)	हाँ / नहीं
(ग)	हाँ / नहीं
(घ)	हाँ / नहीं
(ङ)	हाँ / नहीं

Prob Solv →

16th missing

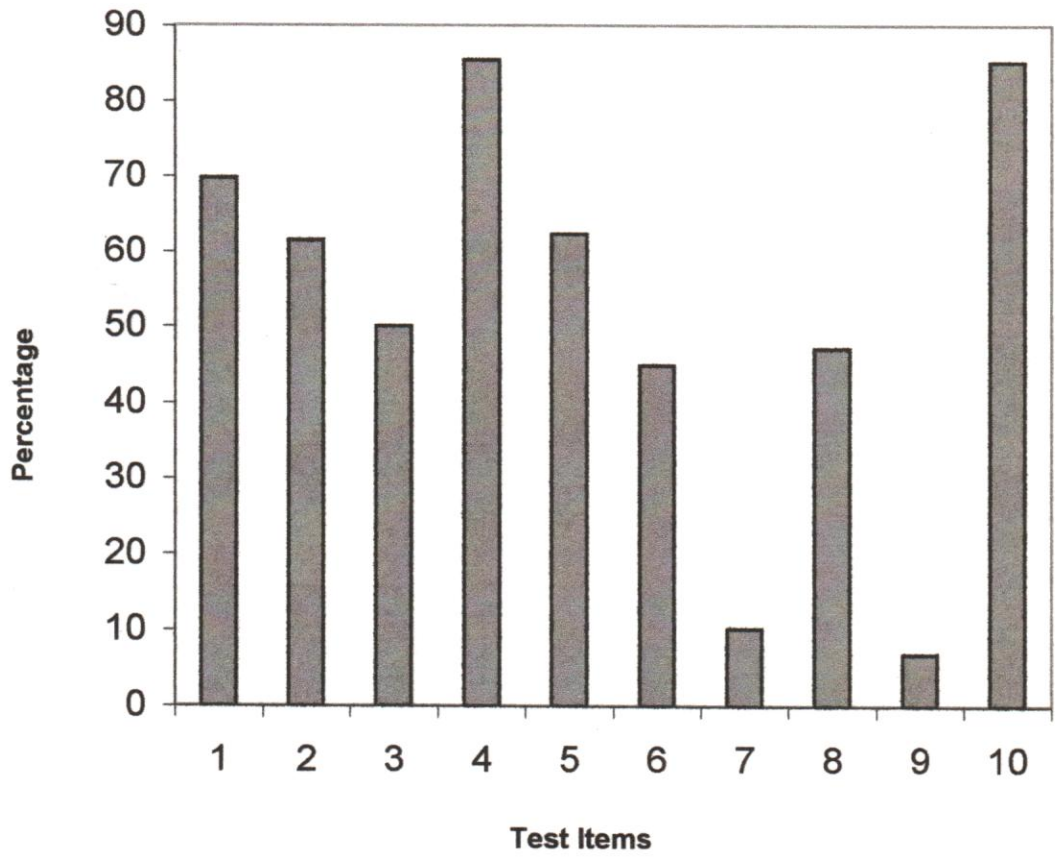

Fig. 1 : Item wise status of Learning Readiness among children

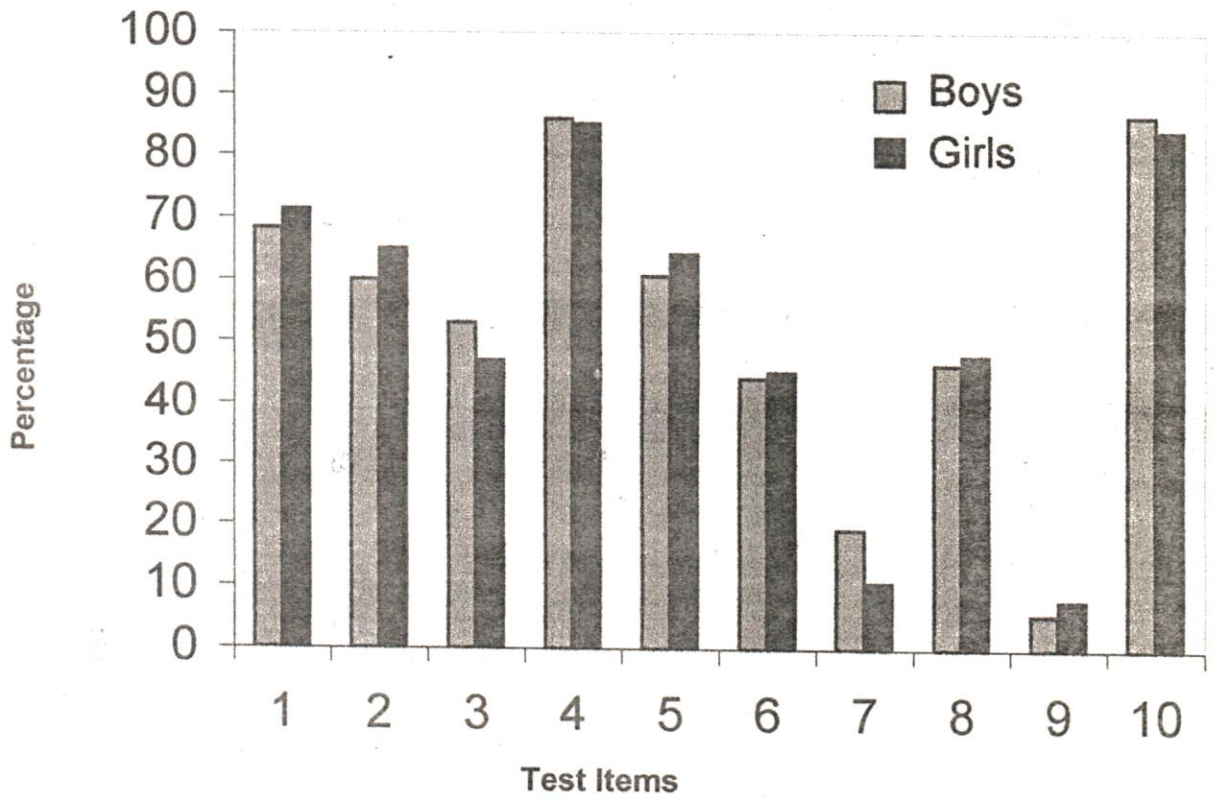

Fig.2: Item wise status of Learning Readiness among boys and girls

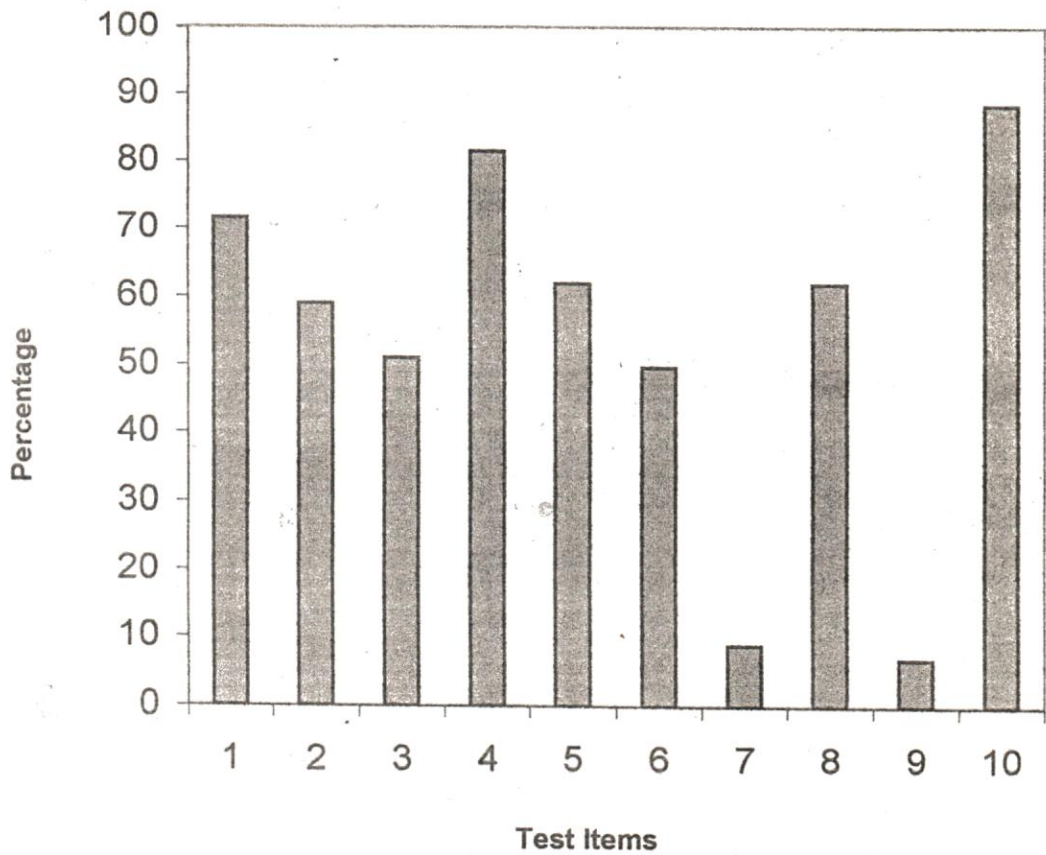

Fig. 3 : Item wise status of Learning Readiness among urban children

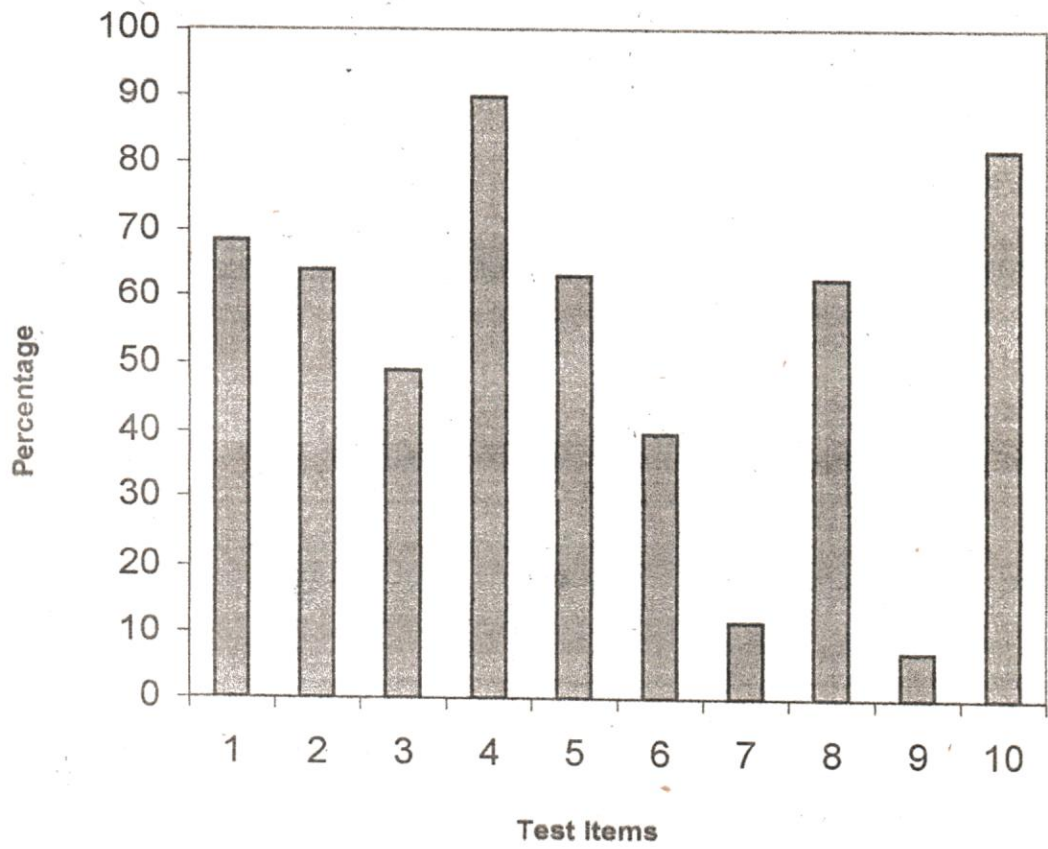

Fig. 4 : Item wise status of Learning Readiness among rural children

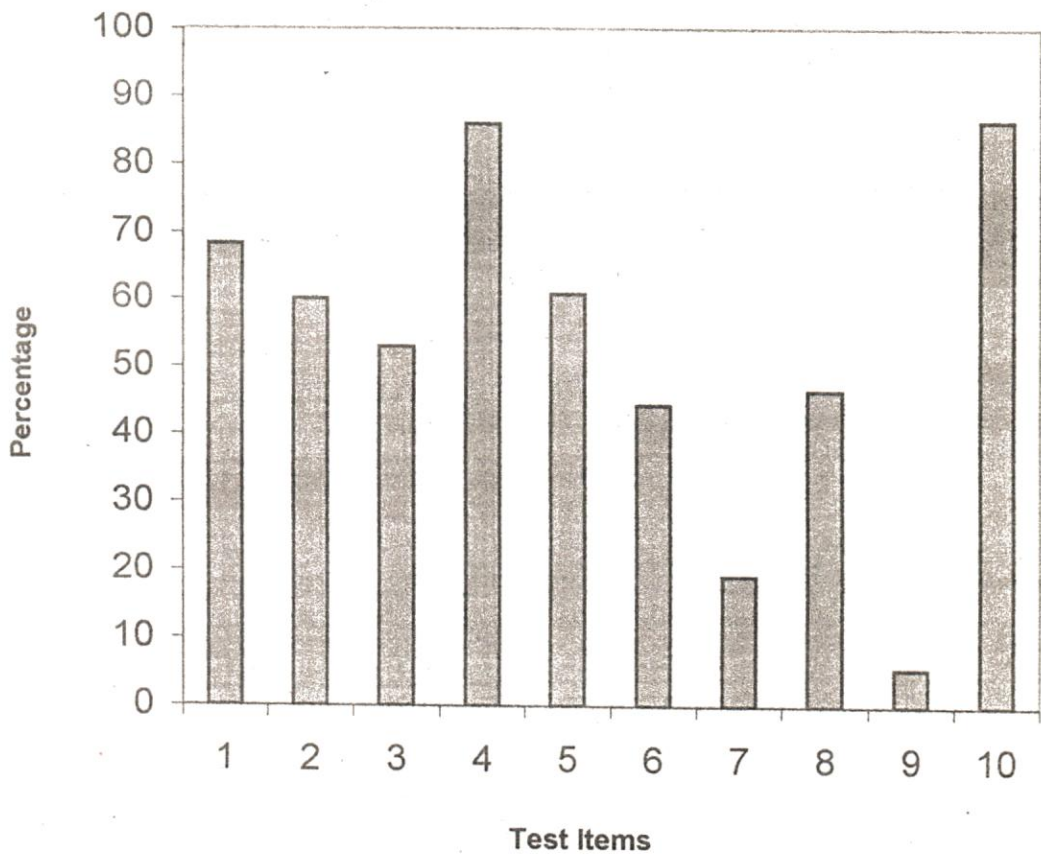

Fig.5: Item wise status of Learning Readiness among boys.

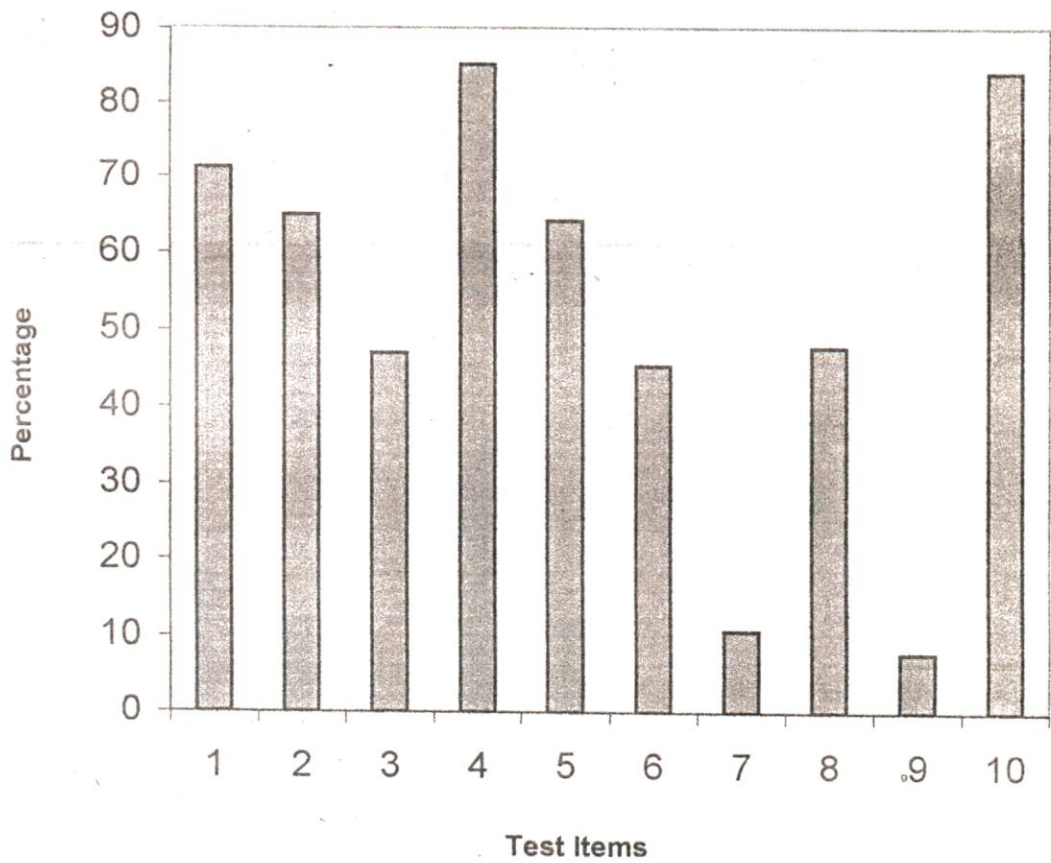

Fig.6: Item wise status of Learning Readiness among girls

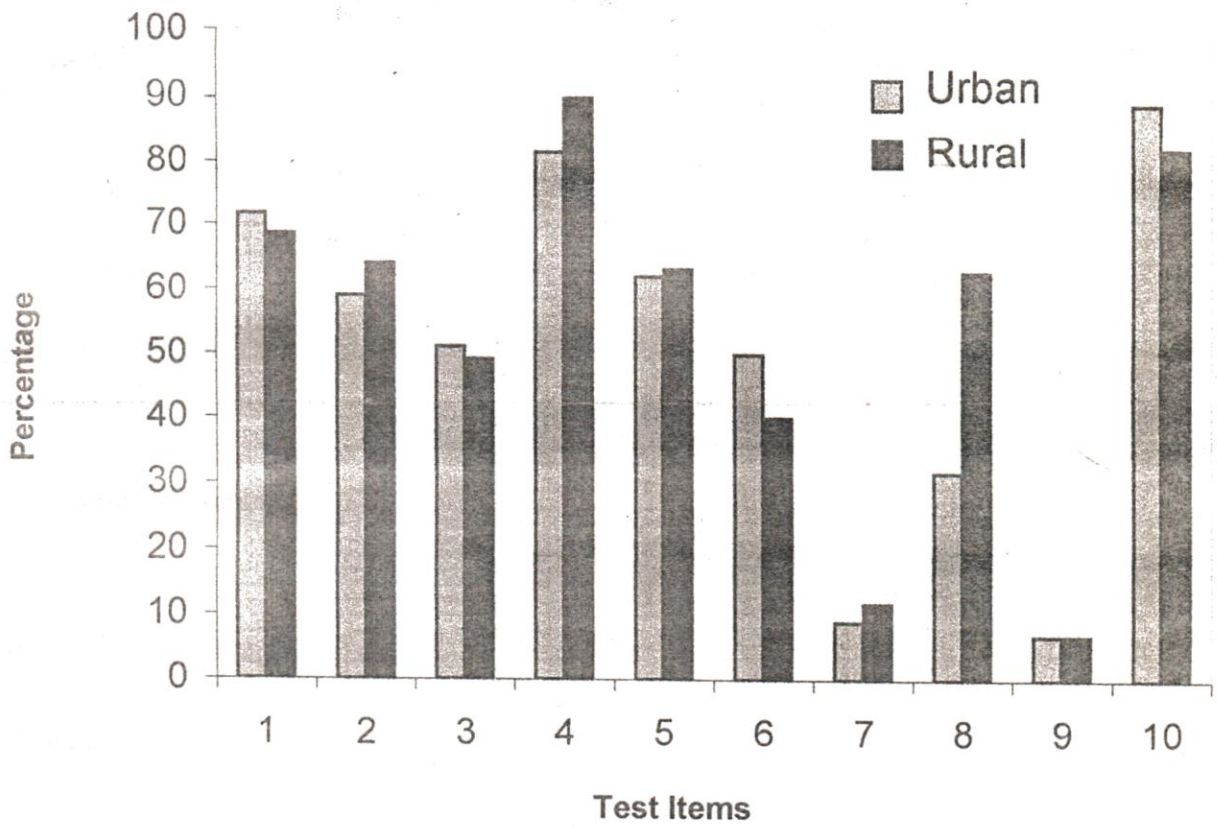

Fig.9 : Item wise status of Learning Readiness among urban and rural children