

PAC 16.37

TRAINING OF KGBV AND EKLAVYA VIDAYALAYA TEACHERS OF CHHATTISGARH ON CONTENT AND PEDAGOGY OF SCIENCE AT SECONDARY SCHOOL LEVEL

विद्यया ऽ मृतमश्नुते



एन सी ई आर टी
NCERT

2017-18

Dr. SHIVALIKA SARKAR
Program Coordinator

REGIONAL INSTITUTE OF EDUCATION, BHOPAL - 462013
(A Constituent unit of National Council of Education Research and Training, New Delhi)



Training program for KGBV and Eklavya Teachers of Chhattisgarh on content and pedagogy of science at secondary school level from 09/01/18 to 13/01/18

**TRAINING OF KGBV AND EKLAVYA VIDAYALAYA
TEACHERS OF CHHATTISGARH ON CONTENT AND
PEDAGOGY OF SCIENCE AT SECONDARY SCHOOL LEVEL**

2017-18

Dr. Shivalika Sarkar
Program Coordinator

Regional Institute of Education, Bhopal – 462013
**(A Constituent unit of National Council of Educational
Research and Training, New Delhi)**

TRAINING PROGRAM

OF

KGBV and Eklavya Vidyalaya teachers of
Chhattisgarh on content and pedagogy of science
at secondary level

(January 9-13, 2018)

विद्यया ऽ मृतमश्नुते



एन सी ई आर टी
NCERT

Dr. Shivalika Sarkar
Program Coordinator
PAC-16.37

Regional Institute of Education Bhopal -462013
(A Constituent unit of National Council of Educational Research and Training, New Delhi)

FOREWORD

The National Council of Educational Research and Training is at a historic moment completing half a century of dedicated work in shaping school education in India. The Council's work stands testimony to its rich contribution to ushering educational reforms and innovations in school education and teacher education.

Teacher performance is the most decisive input in the field of education because it is the teacher who interprets and implements the policies in the grassroots through examples, instructions and influence. In the present information age of technology, knowledge is growing exponentially leading to frequent curricular changes, especially in the subject areas of natural sciences. The teachers are called upon to play varied roles at the same time. In view of the NCF-2005, there is a paradigm shift from teaching to learning through constructivist approach. The programme thus is planned to emphasize on the content and recent pedagogical processes in Science.

Regional Institute of Education, Bhopal, a constituent unit of NCERT, New Delhi conducts innovative pre-service and in-service teacher education programmes. The need of organizing a training program on content and pedagogy of science at secondary level came from Chhattisgarh state. The programme has been designed after consultation with stakeholders of Chhattisgarh, particularly with reference to content and pedagogy.

I take this opportunity to thank my colleagues in the institute and external resource persons for sharing their valuable thoughts in this programme.

Bhopal
January 9, 2018

Prof N. Pradhan
Principal
RIE, Bhopal

PREFACE

Regional Institute of Education, Bhopal organized a five day training program for Eklavya School teachers of Chhattisgarh on content and pedagogy of Science from January 9-13, 2018. A one day workshop was organized at SCERT, Raipur, Chhattisgarh for need assessment on October 10, 2017. After collecting the needs of the teachers, a three days workshop was organized at RIE, Bhopal from December 18-20, 2017 for preparation of the training module. In close consultation with the subject experts and RIE faculty we have planned to give sufficient emphasis on content and pedagogy in Science at Secondary Stage. Several topics related to Physics, Chemistry and Biology have been included in the training program. These topics have been selected keeping in mind the difficulties faced by the teachers in transacting them.

A total of 29 participants from different districts of Chattisgarh participated in the program.

I wish to thank Commissioner, Department of Tribal and Scheduled Caste, Raipur for sending the Eklavya Vidyalaya teachers to attend this training program.

I express my gratitude to Prof. N. Pradhan, Principal, RIE, Bhopal for his valuable guidance all along the course of the program. I am very much thankful to Prof. V.K. Kakaria, Head, Department of Science and Mathematics, RIE Bhopal for his constant support and guidance during the program.

I am also grateful to all resource persons for their interesting and useful deliberations in the program. I also thank Prof. L.K. Tiwary, Head, Department of Extension Education, RIE Bhopal and other administrative staff of the department for the success of the program.

Dr. Shivalika Sarkar

Program Coordinator

Approach Paper

Training of KGBV and Eklavya Vidyalaya teachers of Chhattisgarh on content and pedagogy of science at secondary level

One of the important thrust of NCERT is to organize quality in-service training programmes to enhance the institutional capacity of teachers and teacher educators at all levels of school education in the country. The National Curriculum Framework, 2005 also recognized the need of the professional preparation of teachers. The NCF also elaborated the importance of in-service training programme in the professional growth of teachers and function as an agent for change in school related practices.

The National curriculum Framework (NCF), 2005, recommends that children's life at school must be linked to their life outside the school. The principle marks a departure from the legacy of bookish learning which continues to shape our system and causes a gap between the school, home and community. The syllabi and textbooks developed on the basis of NCF signify an attempt to implement this basic idea. They also attempt to discourage rote learning and the maintenance of sharp boundaries between different subject areas. The success of this effort depends on the steps that school principals and teachers will take to encourage children to reflect on their own learning and to pursue imaginative activities and questions.

At the secondary stage the students should be engaged in learning science as a composite discipline, in working with hands and tools to design more advanced technological modules than at the upper primary stage, and in activities and analysis on issues surrounding environment and health. Systematic experimentation as a tool to discover/verify theoretical principles, and working on locally significant projects involving science and technology are to be important parts of the curriculum at this stage.

The National Focus Group on teacher education formed while developing NCF-2005 strongly recommends that teacher education programmes should be redesigned to respond to the school curriculum renewal process and in accordance with the state and regional context in which they are situated. NCF – 2005 envisions a teacher education programme that should facilitate prospective teachers to understand that learners are active participants rather than passive recipients in the process of learning. They construct their own knowledge by connecting new ideas to the existing ideas on the basis of activities/materials presented to them. Science is dynamic, expanding body of knowledge covering ever new domains of experience. It is an organized system of knowledge which is based on inquiry born out of natural curiosity, logical reasoning and experimentation. The role of a science teacher has evolved in recent years from that of transmitter of knowledge to one of facilitator of knowledge. The teacher is also expected to be a participant in the construction of knowledge and to develop in students an understanding of the nature of science.

Keeping in view the above concerns of science and its pedagogy and to bring quality, excellence and acceptance of diversity in the field of science this training program has been designed to help teachers in teaching-learning of science at secondary level. The program has been designed keeping in mind the needs of KGBV and Eklavya Vidyalaya teachers of Chhattisgarh state.

The content in this module was prepared through a workshop organized at RIE Bhopal involving teachers, subject experts from universities and institutes of higher learning and faculty of the science group of DESM. I gratefully acknowledge their efforts and thank them for their valuable contribution in our endeavor to provide good quality teaching-learning materials to teacher-educators.

CONTENTS

S.No.	Particulars		Page
1.	Foreword		
2	Preface		
3	Approach Paper		
4	Constructivist approach in teaching learning process	Prof. N. Pradhan	1-7
5	E-content development	Dr. N.C. Ojha	8-22
6	Sound	Dr. Kalpana Maski	23-34
7	Chemical Reactions and Equations	Prof. I.P Agrawal	35-42
8	Force and Newton's law of Motion	Dr. Shivalika Sarkar	43-51
9	Motion	Prof. V.G. Jadhao	52-60
10	Heredity	Prof. Pramod Patil	61-67
11	Electric Current and Circuit	Prof. Mukund Bapat	68-71
12	Chemical Bonding	Dr. Rashmi Sharma	72-75
13	Hydrocarbon	Dr. Chitra Singh	76-86
14	Control and Coordination in Plants	Prof. Jaydip Mandal	87-96
15	Conservation of Energy	Prof. Mukund Bapat	97-99
16	Biodiversity	Prof. Suchitra Banerjee	100-108
17	Control and Coordination in Animals	Prof. V.K. Kakaria	109-118
18	Metals and Non Metals	Prof. L.K. Tiwary	119-121
19	Learning Physics by smart phone	Mr. L.S Chouhan	122-125
20	Video based analysis using tracker	Mr. L.S Chouhan	126-138
21	Chemical formula and Mole Concept IPA	Prof. I.P Agrawal	139-146
22	Magnetic effects of electric current	Dr. Kalpana Maski	147-155

PAC 16.37

TRAINING OF KGBV TEACHERS AND MASTER TRAINERS OF EKLAVYA SCHOOL OF CHHATTISGARH ON CONTENT AND PEDAGOGY OF SCIENCE AT SECONDARY SCHOOL LEVEL

1. Introduction

Secondary Education (classes IX and X) is a crucial stage for children as it prepares them for higher education and also for the world of work. It is very essential to provide good quality education available, accessible and affordable to all our children in the age group of 14-16 years. To achieve this, there is a need to strengthen the secondary school education by providing opportunities to teachers for improving their professional capabilities/capacities. In majority of the schools, untrained teachers are handling secondary classes. Even the trained teachers are facing lot of challenges to handle classes at secondary stage of school education especially in science and mathematics. With this vision this PAC program was planned for the KGBV and Eklavya Science teachers at the secondary level in content and pedagogy. To make teachers aware and to train them on different aspects of pedagogy was one of the main motives of the program. Also to bridge the gaps in content areas of science this training program was proposed.

2. Objectives

- (1) To assess the need of KGBV and Eklavya teachers of Chhattisgarh state at the secondary level
- (2) To orient the KGBV and Eklavya teachers of Chhattisgarh state in related content areas of science at the secondary level
- (3) To impart training to KGBV and Eklavya science teachers on constructivist approach
- (4) To impart training to KGBV and Eklavya science teachers on practical skills of secondary level science
- (5) To orient the KGBV and Eklavya science teachers on using different teaching aids in science at the secondary level

3. Methodology

- (1) One day in-house meeting to plan overall program.
- (2) One day workshop for need assessment of KGBV and Eklavya science teachers in Chhattisgarh
- (3) Three days workshop to develop material on the identified concepts
- (4) Five days training for orientation of KGBV and Eklavya science teachers at the secondary level science

4. Need and Justification

The Kasturba Gandhi Balika Vidyalaya (KGBV) scheme was launched by the Government of India in August, 2004 for setting up residential schools at upper primary level for girls belonging predominantly to the SC, ST, OBC and minorities in difficult areas. The scheme is being implemented in educationally backward blocks of the country where the female rural literacy is below the national average and gender gap in literacy is above the national average. The scheme

provides for a minimum reservation of 75% of the seats for girls belonging to SC, ST, OBC or minority communities and priority for the remaining 25% is accorded to girls from families below poverty line. Keeping in view the background of girl students, teaching learning process in the KGBVs should be radical and revolutionary in their outlook and should be much above the prevailing stereotypes in the society. Another issue that needs urgent attention is the use of teaching and learning materials in KGBVs. Textbooks prepared by NCERT in the light of NCF, 2005 and the position paper on 'Gender Issues in Education' may be referred for developing materials for KGBV students. The major issue in KGBV is not related to enrolment and retention but how knowledge is constructed and whether this knowledge links girl with their lived reality. This is also true for the Eklavya Schools which are residential and located in tribal dominated areas. Also training of the teachers should not be merely regarding curriculum and textual materials but also the pedagogy and environment of KGBV and Eklavya schools. Different textbooks and study materials need to be prepared for them in which enough spaces must be given to their local environment, their problems, their interest and also their life experiences. In this context NCERT could contribute in capacity building of the KGBV and Eklavya teachers by using science kits and other teaching – learning material. Capacity building of KGBV and Eklavya teachers is an urgent need.

5. Activities done under the program

Activity I

One day in-house meeting to plan overall program

A one day in house meeting was conducted to plan the overall program. It was decided to conduct one-day need assessment workshop at SCERT, Chhattisgarh.

Activity II

One day workshop for need assessment of KGBV and Eklavya science teachers at SCERT Raipur, Chhattisgarh

The Program coordinator Dr. Shivalika Sarkar along with team member Dr. Kalpana Maski, visited SCERT, Raipur, Chhattisgarh on 09/10/2017. One day workshop for

need assessment of KGBV and Eklavya science teachers in Chhattisgarh was conducted at SCERT, Raipur, Chhattisgarh on 10/10/2017. Nineteen Eklavya Science teachers from different districts of Chhattisgarh participated in the workshop.

The workshop began with a lecture by Dr. Kalpana Maski. The participants were provided SCERT Science Textbooks of Class IX and X. They were asked to give their needs on different topics. Mrs Jyoti Chakroborty, Assistant Prof., SCERT Raipur briefed the participants about the program.

Participants discussed their problems on different topics in groups. This was followed by presentation of each group on their needs on different topics.



Group Discussion at one-day workshop for need assessment organized at SCERT, Raipur

Participants gave their needs on different topics of Class IX and X Science in content as well as pedagogy. They expressed difficulty in explaining the different diagrams given in the SCERT Science Textbook. They also found it difficult in designing and conducting activities on different topics. Specific difficulties of the teachers on different topics is given in Annexure I. Valedictory session was chaired by Honorable Director, SCERT Raipur, Shri Sudheer Kumar Agrawal. He urged the need of conducting innovative teacher training programs for Eklavya Science Teachers and discussed the difficulties of the teachers in their respective schools.

Activity III

Three days workshop to develop material on the identified concepts

After need assessment was done it was planned to conduct three days workshop to develop material on the basis of need of the teachers. Three days workshop was organized at Regional Institute of Education, Bhopal from December 18-20, 2017. Sixteen resource persons participated in the workshop. Different resource persons after going through the needs of the teachers developed their modules on different topics. In close consultation with the subject experts and RIE faculty we have planned to give sufficient emphasis on content and pedagogy in Science at Secondary Stage. Several topics related to Physics, Chemistry and Biology have been include in the training program. These topics have been selected keeping in mind the difficulties faced by the teachers in transacting them. While designing the training package it was decided to include knowledge on pedagogy, content, curriculum, technology, knowledge of students and the possible misconceptions which will be strongly emphasized throughout the program

Activity IV

Five days training of KGBV and Eklavya science teachers of Chhattisgarh on content and pedagogy of secondary level science

After developing the training package on the basis of need of the teachers five days training program was organized from January 9-13, 2018. A total of 29 participants from different districts of Chhattisgarh participated in the program. The training program on content, Pedagogy and the emerging trends was planned to empower the teachers with exposure to multi-dimensional approach towards teaching – learning process. The Inaugural Session began with introduction of the aims and objectives of the program by the program coordinator Dr. Shivalika Sarkar followed by the overview of the program given by Head, Department of Extension Education, Prof. L.K. Tiwari. Honorable Principle, RIE Bhopal, Prof. N. Pradhan shared his vision about the training programs organized at RIE Bhopal. Keynote speech was given by Prof. N. Pradhan on Constructivism Approach in Teaching Learning Process. 21 Sessions on different topics of Physics, Chemistry and Biology were included along with lab sessions.

The Indoor visit to Science Park widened the horizon of the participants towards innovation and creativity and so was the group presentation in providing a platform for peer, collaborative learning and exchange of innovative ideas amongst the teachers. The Diverse aspects of science education covered in the program on the whole promoted a very holistic view on teacher's professional development.

The Valedictory function, chaired by the Honorable Director NCERT, Prof. H.K. Senapaty presided at the Valedictory Function of the training program. His interaction with the participants was very powerful in boosting the teachers as facilitators in Nation building. Reflections on the program by the participants were also obtained.

Principal RIE Bhopal and Head Department of Extension Education, RIE Bhopal also presided over the function. Principal RIE Bhopal, gave his concluding remark on importance of the application of the things learned from the program by the participants in real classroom situations and their willingness to extend every kind of support and urged the teachers to have a very free interaction with the resource persons of NCERT for all sorts of issues with regard to Science education and future interventions. Vote of thanks was given by the program coordinator, Dr. Shivalika Sarkar.



Participants from Ekalvyas Schools of Chhattisgarh state during the training program

Feedback Analysis

Participants were given feedback forms and feedback was also obtained during the training program on a daily basis. Several topics were new for the participants.

Summary of the feedback

1. Econtent: - This was the first opportunity for participants to learn the development of E content. They also visited the RIE Bhopal studio and got involved in e content development. This session was very interesting for the participants.

2. Constructivism Approach in Teaching Learning Process – First time participants were exposed to the constructivist theory of learning. They found this session very useful and interesting.

Different topics of physics, chemistry and biology like chemical reaction and equation, optics biodiversity and conservation of life, metals and nonmetals force, laws of motion, electric current and circuit were appreciated by the participants. Physics, Chemistry and Biology laboratory work gave a chance to the trainees to perform many different experiments and activities in the laboratory life

Topics to be included

Participants requested the inclusion of the following topics in the future training programs

- 1.Space Science
2. Computer Science
3. Magnetism
4. Sound
5. Waste management

Constructivism and Classroom Teaching

Prof. N.Pradhan

Principal

RIE, NCERT, Bhopal

E-mail: npradhan17@rediffmail.com

The term constructivism refers to the idea that individuals, through their interaction with the environment construct their own knowledge and meaning (Fosnot 1996; Steffe and Gale, 1995). This metaphor of construction comes from the idea that humans are builders, shapers, and designers, who throughout history have created artifacts from pots to skyscrapers. All these tangible products were and are still being built through the process of selecting the materials, arranging or mixing the materials together, resulting in a whole that is greater than some of its parts (Spivey, 1997). However, as humans we also create mental products or meanings as well as creating things. The emphasis of the constructivist theory is on the process, rather than the product of learning. A constructivist approach would have the student determine how much they have learned as well as the process by which they have come to know. Such a theory of knowledge and learning has significant implication for teaching. It changes the dynamics of the traditional classroom by empowering the learner as the focus and architect of the learning process while redefining the role of the instructor to be a guide and helper, rather than the source and conduit of knowledge. Constructivism has become an educational theory of choice for many within modern educational institutions. Gaining insight into its core pedagogical principles and how these principles determine/influence the major aspects of classroom instruction, e.g. role of the teacher, instructional strategy, evaluation, is important on the part of the teachers and the teacher-educators who really want to participate in this movement.

Assumptions of Constructivist Learning Theory

The constructivist learning theory is based on the following four major assumptions

- Knowledge depends on past constructions. We know the world through our mental framework and we transform and interpret new information through this framework.
- Constructions come through systems of assimilation and accommodation into our existing mental framework.
- Learning is an organic process of invention, not mechanical.
- Meaningful learning occurs through reflection and scaffolding of new knowledge upon existing framework of knowledge.

Characteristic of constructivist learning

- Goals and objectives are derived either by the learner or in negotiation with the teacher or system
- Teacher plays the role of facilitator, guide monitor and coach
- Learner plays a central role in mediating and controlling learning
- Knowledge construction and not reproduction is emphasized

- Knowledge construction takes place in individual contexts and through social negotiation, collaboration and experiences
- Learners' previous knowledge, beliefs and attitudes are considered in the knowledge construction process
- Learning environments are created where activities, opportunities, tools are provided to encourage meta-cognition, self-analysis, self-regulation, self-reflection and self-awareness
- Content, skills, tasks and learning situation are relevant, realistic, authentic and represent the natural complexities of the 'real world'
- Primary sources of data are used to ensure authenticity and real-world complexity
- Problem-solving, critical and creative thinking skills and deep understanding are emphasized
- Wrong answers provide the opportunity for insight into students previous knowledge construction
- Learners are encouraged to explore the new knowledge independently and to manage the pursuit of their goal
- Learners are provided with the opportunity for apprenticeship learning in which there is an increasing complexity of tasks, skills, and knowledge construction
- Conceptual interrelatedness and interdisciplinary learning are emphasized which reflex knowledge complexity
- Collaborative and cooperative learning are focused in order to expose the learner to alternative viewpoints and encourage social interaction
- Scaffolding facilitate to enable students perform just beyond the limits of their ability
- Assessment is interwoven with teaching

Constructivist Pedagogy

Instruction that is based on constructivist principles is extremely demanding of the teacher. Constructivist pedagogy is the link between theory and practice. Many theorists and practitioner (Brooks and Brooks, 1993; Driscoll, 1994; Jonassen, 1991) have generated constructivist pedagogies with an array of results. While these pedagogies share a set of core design principles, the peripheral principles tend to vary greatly. The general theoretical and practical constructivist principles indicates that eight factors are essential in constructivist pedagogy (Brooks and Brooks, 1993; Larochelle, Bednarz and Garrison, 1998; Steffe & Gale, 1995).

Learning should take place in authentic and real-world environments

Experience, both socially oriented and object oriented, is a primary catalyst of knowledge construction. Experience provides the activity upon which the mind operates. In addition, knowledge construction is enhanced when the experience is authentic.

(i) Learning should involve social negotiation and mediation

While only social constructivism emphasizes social interaction as a basis for knowledge construction, cognitive and radical constructivism do assign social interaction a role. Social interaction provides for the development of socially relevant skills and knowledge. In some cases, e.g. greetings, gender relations, dress, knowledge can only be attained through social contact. As an individual gains experience in a social situation, this experience may verify his

knowledge structure or it may contradict those structures. If there is contradiction or confusion, then the individual must accommodate this contradiction in order to maintain an accurate or social model of reality. Language is the medium through which knowledge and understanding are constructed in social situations (Spivey, 1997).

(iii) Content and Skills should be made relevant to the learner

Constructivism emphasizes the concept that knowledge serves an adaptive function. The knowledge attained, i.e. content and skills, in order to enhance one's adaptation and functioning, must be relevant to the individual's need, understanding, and goal. This relevancy is likely to increase the individual's motivation. Ultimately, experience with relevant tasks will provide the individual with the mental process and social experiences necessary for enhanced functioning within one's practical environment.

(iv) Content and skills should be understood within the framework of the learner's prior knowledge

All learning begins with an individual's prior knowledge, regardless of constructivist affiliation. Understanding a student's behaviour requires an understanding of the student's mental structure, i.e. an understanding of the student's understanding. When a student replies that the answer to $54 - 38$ is 24, the teacher must not think it immediately to be wrong, but rather try to understand the student's understanding of subtraction that has led to this answer. In this case, the student appears to be using the following rule of subtraction: "Subtract the smallest from the largest". Understanding the student's rule usage makes it much easier for the teacher to demonstrate the non-viability of the student's understanding. The teacher in this case, for example, may ask the student to count out 54 blocks, then take away 38 blocks from that pile, and finally count the remaining 16. Only by attempting to understand a student's prior knowledge will the teacher be able to create effective experiences, resulting in maximal learning.

(v) Students should be assessed formatively, serving to inform future learning experiences.

Constructivism asserts that the acquisition of knowledge and understanding is an ongoing process that is heavily influenced by a student's prior knowledge. Knowledge and understanding are not directly visible, but can be inferred from one's action. Thus, to take into account an individual's current level of understanding in this ongoing teaching-learning process, a teacher must continually assess the individual's knowledge. This formative assessment is necessary to create the subsequent series of experiences and activities for the students.

(vi) Students should be encouraged to become self-regulatory, self-mediated, and self-aware

The underlying tenet of constructivism is that learners are active in their construction of knowledge and meaning. This activity involves mental manipulation and self-organization of experiences; and requires that students regulate their own cognitive functions, mediate new meaning from existing knowledge, and form an awareness of current knowledge structures. Within a cognitive constructivist perspective, self regulation, self-mediation, and self-awareness would be subsumed under the construct of metacognition. Metacognition is considered an essential aspect of learning and consists of (i) knowledge of cognition, and (ii)

regulation of cognition (Brown & Palincsar, 1987). Vygotsky (1978) believed that students construct mental signs or psychological tools to represent concepts and relationships, and that these tools are used to mediate cognition. Similarly, Piaget (1977) theorized that students mentally reflect on the use and nature of objects and then construct new knowledge by generalizing new relationships.

(vii) Teachers serve primarily as guides and facilitators of learning, not instructors

The role of the teacher, in constructivist perspective, is to motivate, provide examples, discuss, facilitate, support, and challenge, but not to transmit knowledge. In the cognitive constructivist perspective, the role of the teacher is to create experiences in which the students will participate that will lead to processing and acquisition of knowledge. On the other hand, social and radical constructivism argue that the only role of the teacher is to guide students to an awareness of their experiences and socially agreed-upon meanings. They advocate that there is no factual knowledge to transmit.

(viii) Teachers should provide for and encourage multiple perspectives and representations of content

The relationship of multiple perspectives and multiple representations is one of cause and effect. Experiencing multiple perspectives of a particular event provides the student with the raw materials necessary to develop multiple representations. These multiple representations provide students with the ability to develop more complex schemas relevant to the experience. In a nut-shell, multiple perspectives provide the students with a greater opportunity to develop a more viable model of their experiences and social interactions.

Constructing Knowledge in the Classroom

Research on instructional advancement of the last 30 years, particularly in the areas of cognitive processing, teacher effects, and teaching of cognitive strategies, revealed that the constructivist view affects all the important aspects of the teaching-learning process, including classroom environment. A constructivist classroom is no longer a place where the teacher pours knowledge into passive students, who wait like empty vessels to be filled. Students are actively involved in the learning process and given the opportunity to construct knowledge based on their own background. In specific terms, a constructivist classroom bears the following characteristics (Brooks & Brooks, 1993) :

Students' autonomy and initiative are accepted and encouraged

By respecting students' ideas and encouraging independent thinking, teachers help students attain their own intellectual identify. Students who frame questions and issues and then go about analyzing and answering them, take responsibility for their own learning and become problem solvers.

The teacher asks open-ended questions and allows wait time for responses.

Reflective thought takes time and is often built on others' ideas and comments. The ways teachers ask questions and the ways students respond will structure the success of student inquiry.

Higher-level thinking is encouraged.

The constructivist teacher challenges students to reach beyond the simple factual response. He encourages students to connect and summarize concepts by analyzing, predicting, justifying, and defending their ideas.

Students are engaged in dialogue with the teacher and with each other.

Social discourse helps students change or reinforce their ideas. If they have the chance to present what they think and hear others' ideas, students can build a personal knowledge base that they understand. Only when they feel comfortable enough to express their ideas will meaningful classroom dialogue occur.

Students are engaged in experiences that challenge hypotheses and encourage discussion.

When allowed to make prediction, students often generate varying hypotheses about natural phenomena. The constructivist teacher provides ample opportunities for students to test their hypotheses, especially through group discussion of concrete experiences.

The class uses raw data, primary sources, manipulatives, physical, and interactive materials.

The constructivist approach involves students in real-world possibilities, then helps them generate the abstractions that bind phenomena together.

The 5 E's Model of Constructive Learning

The 5 E model of constructive learning envisages all the principles of constructivism.

1. **Engage**– Students encounter the material, define their questions, lay the groundwork for their tasks, make connections from new to known, and identify relevance.
2. **Explore** – Students directly involved with material, inquiry drives the process, teamwork is used to share and build knowledge base.
3. **Explain** – Learners explain the discoveries, processes, and concepts that have been learned through written, verbal or creative projects.
4. **Elaborate**– Learners expand their knowledge, connect it to similar concepts, apply it to other situations can lead to new inquiry.
5. **Evaluate**– It is an on-going process by both instructor and learner to check for understanding. Rubrics, checklists, teacher interviews, portfolios, are used to evaluate and modify further instructional needs.

Conclusion

The constructivist view of the world as having reality only as it is understood by the learner signals a dramatic departure from theories which view the world as objective truth to be explained and accepted. This change represents a fundamental shift in the understanding of the learning relationship. It gives new status to the learner as the active constructor within the learning activity instead of being the passive respondent to externally determined world of education. Constructivism challenges learners to move beyond fact learning to more transportable cognitive understanding. It defines teaching to be an exciting process of joining in the intellectual discovery of others. The constructivist teacher becomes a partner who is given the opportunity to see familiar educational vistas through new eyes and in a real sense becomes a fellow learner with the students he serves. Becoming a constructivist teacher may prove a difficult transformation since most instructors are prepared for teaching in the traditional manner.

References

- Bendar A.K. Cunningham, D., Duffy, T.M., and Perry J.P. (1995). Theory into Practice : How do we Link ? In T.M. Duffy and D.H. Jonassen (Eds.) *Constructivism and Technology of Instruction – A Conversation*, Lawrence Erlbaum Associates, Hillsdale, NJ, pp.17-34.
- Brooks, J.G.and.Brooks, M.G. (1993). In search of understanding : The case for constructivist classroom, Association for Supervision and Curriculum Development, Alexandria, VA.
- Brown, A.L. and Palincsar, A.S. (1987). Reciprocal Teaching of Comprehension Strategies : A Natural History of One Program for Enhancing Learning; In J.Brokoowski and J.D. Day, (Eds.), *Cognition in Special Education : Comparative Approach to Retardation, Learning Disabilities, and Giftedness*, Ablex, Norwood, NJ.
- Brown, J.S., Collins, A., and Duguid, P. (1989). Situated Cognition and the Culture of Learning, *Educational Researcher*, (January / February). 18, 32-42.
- Driscoll, M. (1994). *Psychology of Learning for Instruction*, Allyn and Bacon, Boston.
- Fosnot, C.T. (1996). *Constructivism : Theory, Perspective, and Practice*, Teachers College Press, New York.
- Hunter, M. (1982). *Mastery Teaching*, P.O. Box 514, EI Segunda, CA : TIP Publications.
- Jonassen, D.H. (1991). Objectivism versus Constructivism, Do We Need a New Philosophical Paradigm ? *Educational Technology Research and Development*, 39 (3), 11-12.
- Larochella, N., Bednarz, and Garrison, J. (1998). *Constructivism and Education* (Eds.), Cambridge Press, Cambridge.
- Mayer, R.E (1992). Cognition and Instruction : On their Historic Meeting within Educational Psychology, *Journal of Educational Psychology*, 84, pp. 405-412.
- Mayer, R.E (1996). Learning Strategies for Making Sense out of Expository Text : The SOI Model for Guiding Three Cognitive Process in Knowledge Construction, *Educational Psychology, Review*, 8, pp. 357-371.
- Palincsar, A.S. and Brown, A.L. (1984). Reciprocal Teaching of Comprehension-Fostering and Comprehension-monitoring Activities. *Cognition and Instruction*, 2, pp. 117-175.
- Piaget, J. (1977). *The Development of Thought : Equilibrium of Cognitive Structures*, Viking, New York.

- Pressley, M., Burkell, J., Cariglia-Bull, T., Lysynchuk, L., McGoldrick, J. A., Schneider, B., Smons, S. & Woloshyn. (1995) .*Cognitive Strategy Instruction(Eds.)*, Brookline Books, Cambridge, MA.
- Rosenshine, B. (1996). Advances in Research on Instruction “In J.W. Lyoyd, et al. (1997). Eds. *Issues in Educating Students with Disabilities*., Lawrence Erlbaum Associates, Mahwah, NJ.
- Resenshine, B. & Stevens, R. (1986). Teaching Functions., In M.C Wittrock, *Handbook of Research on Teaching*, 3rd Edition. Macmillan, New York.
- Scardamalia, M. & Bereiter, C. (1985). Fostering the Development of Self-Regulation in Children’s Knowledge Processing. In S.F. Chimpman, J.W. Segal, & R. Glaser (Eds.) *Thinking and Learning Skills : Research and Open Questions* : Lawrence Erlbaum Associates. Hillsdale, NJ.
- Sharma ,S. (2001). Constructivism, Paradigm Shift, In *Perspectives in Education*, 17 (2), 78-88.
- Spivey, N.N. (1997). *The Constructivist Metaphor*, Academic Press, Boston.
- Steffe, L.P. and Gale, J. (1995). *Constructivism in Education* (Eds.). Lawrence Earlbaum Associates, Hillsdale, NJ.
- Vygotsky, L.S. (1978). *Mind in Society : The Development of Higher Psychological Process.*, Harvard University Press, Cambridge, M.A..

DEVELOPMENT OF E-CONTENT

Dr. N.C.Ojha,

Regional Institute of Education,

NCERT, Bhopal

Wide varieties of digital materials which are of educational significance are available online. Some of the quality materials which are available free of cost or with minimum restrictions can be used, re-used and modified by teachers and students for their teaching and learning. As textbooks are too expensive, the students are switching from textbooks to digital course materials. These materials provide both teachers and students a greater interactivity and social collaboration. One of the materials which can be designed and developed used, re-used and distributed is e-content.

E-content is becoming popular because of its flexibility of time, place and pace of learning. E-content includes all kinds of content created and delivered through various electronic media. E-content is available in many subjects and almost all levels of education. It can be used by wide variety learners with diverse needs, different backgrounds, and previous experience and skill levels. It can be shared and transmitted easily and promptly among unlimited number of users around the world. Teachers, students and others get benefited by the use of well designed and developed e-content. It is advantageous to the educational organizations to make their program accessible to their teachers and students on campus, home and other community learning or resource centers. It has a significant implications for open and distance learning institutions.

It encompasses eTexts and digital learning resources. These could be digital textbooks, workbooks, articles, videos, or multimedia. Switching from traditional textbooks to digital course materials is a growing trend in higher education. Advantages for students and faculty include greater interactivity, customizability, and opportunities for social collaboration.

Electronic content (e-content) which is also known as digital content refers to the content or information delivered over network based electronic devices or that is made available using computer network such as internet. According to Oxford dictionary 'e-content is the digital text and images designed to display on web pages'. According to Saxena Anurag (2011) 'E-content is basically a package that satisfies the conditions like minimization of distance, cost effectiveness, user friendliness and adaptability to local conditions'.

Well developed e-content can be delivered many times to different learners. Individual course components i.e. units, lessons and media elements such as graphics and animations can be re-used in different contexts.

The purpose of e-content development is to create an information rich society. Every one in the society is empowered to create, receive, share and utilize information for their progress. Very well designed, developed and validated e-content will provide access to high quality meaningful digital content and serve as an effective virtual teacher.

E-content design, development and approach will depend upon the nature of the content and the learners. It will also depend on the quality and complexity the learning you wish to create. Various instructional design models are available according to our requirements. Most of the models involve the process of analyzing the learner needs and goals of the instructional

material development, development of a delivery system and content, pilot study of the material developed, implementation, evaluating, refining the materials etc. In designing and development of E-content we have to adopt one of the instructional design models based on our requirements. Before understanding the designing and development of e-content it is essential to understand the meaning of instructional design.

According to Wikipedia '**instructional design** is the practice of creating instructional experiences which make the acquisition of knowledge and skill more efficient, effective and appealing. The process broadly consists of determining the current status of learner understanding, defining the end goal of the instructional material and creating some 'intervention' to assist the transition. This systematic approach provides a step by step process for the analysis of the learners' needs, the design and development of the material'. Most common and popular model used for creating instructional materials is the **ADDIE** model. This abbreviation stands for the five phases involved in the model. They are **analyze, design, develop, implement and evaluate**. This model is initially developed by Florida State University to explain the processes involved in the formulation of an instructional systems development (ISD) program for military inter-service training. ISD was meant for training individuals to do a particular job. This can also be applied to any inter-service curriculum development activity. Originally the model contained several steps under its five original phases (analyze, design, develop, implement and evaluate). Over the years the steps were revised and finally the model itself became more dynamic and interactive.

Analysis: It is the first phase of this model meant for examining the suitability of the e-content to be developed. It is related to analyzing the learning needs, context, learner, task and content. Analyzing the learning needs is identifying the needs from the perspective of different learners, teachers, subject experts, practitioner, policy makers etc. Needs are to be clearly stated.

- **Contextual analysis** is collecting data related to the context of learning such as learning environment. Whether the e-content developed is for the individual or group, formal or informal, facilitated or self-learning etc.
- **Learner analysis** is collecting data related to learners academic levels and attributes such as skills, motivation, visual literacy, language competency, learning styles etc. That is nothing but preparing the learner profile. It helps to know about the learner.
- **Task analysis** is stating the purposes of developing the e-content. Deciding whether that is developed for educating, training, creating awareness, developing skills etc.
- **Content analysis** is nothing but preparing a content outline. Good content comprehension is required before designing and developing content. It includes verifying the content with respect to cognitive appropriateness, factual accuracy, completeness etc. It also includes classifying the content into facts, concepts, principles, processes and procedures.

Design: It is concerned with defining the learning objectives, structuring the content logically, specifying the instructional and evaluation strategies, and preparing for visual and technical design.

existing knowledge, skills, language proficiency, vocabulary, likes, dislikes, preferences and information needs. It is also important to know about the context or conditions in which the audio/video programmes will be listened/viewed by these audiences.

Access to and knowledge of this kind of learner profile is very useful for educational audio and video scriptwriters. It gives them greater insight into learners' needs and helps in tackling their communication problems. Such detailed information about the target audiences is also useful in formulating precise learning objectives and identifying appropriate content and presentation formats for different programmes. Similarly, need assessment studies help in ascertaining the actual needs of the target audiences and identifying suitable programme topics, themes and content areas. Audio and video scriptwriters can certainly develop relevant need-based scripts and programmes if they are familiar with the needs, interests and characteristics of their specific learner groups.

Instructional objectives and programme briefs.

Another necessary condition for a scriptwriter to be able to write a meaningful and effective audio or video script is concerned with 'what' and 'why' of a programme or what is generally known as 'programme objectives'. Therefore, the crucial questions that a scriptwriter must ask himself/herself right in the beginning are:

- Why am I writing this script? Or, in other words, what are the instructional objectives I am required to achieve through this programme script?
- What is the precise content to be presented? Does the content really lend itself to audio or video treatment?
- What do I want to happen to my audiences through this particular programme or a series of programmes (in terms of gaining knowledge, information or acquiring certain skills, or influencing their attitudes, habits, behaviors, etc.)?

When analyzed and researched further, these questions get expanded into what we call a 'programme brief' or 'an academic note' or a 'programme outline'. A programme brief is a written, typed or printed statement of intent. It represents a 'road map' that traces the scripting path from the beginning to the end. It serves as a basic document that provides all related content – information, ideas, sources and suggestions – for a proposed audio or video programme at one place. Researchers and scriptwriters can freely draw upon such materials to design their scripts. A programme brief should usually include the following information:

- Series title
- Programme title (working title only)
- Target audience (their characteristics, needs, and entry behavior)
- Programme length or duration
- Programme objectives (stated in behavioural terms)
- Brief content outline (preferably in distinct sequences matched with one or more programme objectives)
- Expected learning outcomes (as reflected from objectives, but more concrete and performance-oriented)
- Suggested treatment and production hints (for each sequence)

- **Learning objectives** are to be defined in clear, realistic and measurable terms. Learning objectives are the statements that describe what the learner will be able to do at the end of the course or program. Learning objectives should specify performance and communicate their purposes. Prepare a detailed content outline in which content is thoroughly analyzed and logically organized. Content is to be structured logically following simple to complex, known to unknown, concrete to abstract, general to specific etc.
- **Instructional strategies** are to be stated clearly. Depending on the learning style and nature of the content we have to decide the appropriate instructional strategy. Appropriate **media mix** that is combination of audio, video, graphics, animation; simulation etc is to be decided.
- **Learner evaluation strategies** such as practice, computer marked or tutor marked assessments, pretest, post-test, remedial tests etc are to be specified. We have to decide about the formative and summative assessments. Before developing the content for the selected course review the proposed learning objectives. Make sure that content, assessment tests and exercises match the objectives stated. Provide the information and knowledge required to meet the learning objectives.

Development: It is related to the creation of story board. **Story board** is nothing but scripting the entire course content. The term ‘story board’ is taken from film production. In a movie it indicates the visual representation of the various scenes. In e-content development the story board describes step by step script of the final outcome of the e-content i.e. story board is created to provide a blue print of the course with each and every detail along with the content notes. The story board is created based on the objectives and instructional strategies. Here the developers create and assemble the content assets and learning objects. **Programming and integration** of all media elements into a cohesive multimedia package are the part of this phase.

Implement: In the implementation phase, materials are distributed to learners. A comprehensive implementation strategy document is developed. This document should cover the course curriculum, learning outcomes, method of delivery in terms of hard ware and soft ware requirements and testing procedures. Ensure that the web site is functional if the material is on the web site.

Evaluation: The evaluation phase consists of two parts i.e. Formative and summative evaluation. Formative evaluation is present in each stage of the ADDIE process. Summative evaluation determines the adequacy of the distributed materials in achieving the course objectives. Material is to be revised at all the stages based on the feedback received.

Learner’s Characteristics and needs

Educational audio and video materials are invariably addressed to specific learner groups of conventional or ODL systems. It is, therefore, of utmost importance that audio/video scriptwriters have as much information as possible about their target audiences. In ODL systems where learners are placed at a distance and are scattered and almost invisible, it is all the more important to have such vital information about them, viz. their age, sex, maturity level, attitudes, beliefs and aspirations, socio-economic background, lifestyles, (urban/rural),

- Write in a simple language, using short sentences so that he/she is understood correctly, and not misunderstood.

General guidelines for radio/audio scriptwriting

Writing for educational audio/radio programmes appears to be a rather simple activity. It is, however, not so in actual practice. It is a demanding task that requires a lot of creativity and imagination. Whereas the ways to writing may vary from writer to writer, the process of script development entails a few essential steps, which all writers follow consciously or unconsciously. The general guidelines that we present below will provide you a better insight into the scriptwriting process for radio/audio.

Carry out programme research

Once you have acquainted yourself fully with a particular 'programme brief' or have thoroughly understood the scriptwriter's mandate in terms of general objectives, content, target audience and programme length, your first task is to carry out a thorough research on the given topic/ content by consulting books, journals, experts and other knowledgeable people or subject specialists. You must keep your target audience and programme objectives in focus while selecting appropriate content and authentic information. You must also ensure that your facts are correct and up-to-date. You must double check every bit of information before you put in your script. Always look for some information that may enrich and provide interest to your storyline. Select only the most relevant content, resources and ideas, which match your programme objectives.

Select key ideas

The next step is concerned with the selection of content for the programme. Here, you have focus on the basic content and reduce it to a few key ideas. Put these key ideas in a logical sequence and this will help you define the main focus or the central theme of your program. You will also be able to decide on the weightage and emphases you need to give to different programme objectives.

Make a plan

At this point, you are ready to concretize your presentation strategy. You may choose a special format or combination of formats to put your content in certain style, pace and sequential continuity. You are ready with a detailed story structure or script outline, which is essential for designing a draft script.

Write your draft script

While putting your draft script on paper, the most essential rule to follow is to always keep individual listener in focus. That means you must address your writing to one person, not thousands and millions of distance learners. Radio, of course, is a mass medium, yet you will end up in the mind of one person, i.e. the individual listener. Radio writing is, therefore, an intimate, one-to-one talk. It is just 'you' and 'me'. By that reason, you must consciously construct your sentences in 'active voice'.

Think of a good beginning and a good end

Usually, detailed programme briefs are designed jointly by a team consisting of subject experts, instructional designers, researchers, scriptwriters, and media producers. Programme briefs serve as basic reference material for scriptwriters, researchers, producers and evaluators. Programme briefs facilitate the scriptwriters and producers to the given mandate and help them remain on track while developing audio and video scripts and producing final programmes.

Script as the core of the programme

The script is the foundation of any programme whether for stage, radio, film, television or videotape. It is created and evolved step by step into a carefully designed blueprint that provides detailed instructions for actors/participants, technicians and producers who finally transform the script into a worthwhile listening experience or a viewable programme. In the ultimate analysis, the script is the 'core' of any educational audio or video programme. In other words, we can say that it is the quality of the script that determines the quality of the programme.

At this point, we may return to the basic questions raised earlier. How are educational audio and radio scripts planned and developed? What is the scripting process like? What are the steps involved in the scriptwriting process?

Undoubtedly, planning and writing educational audio/video scripts is a demanding task. It requires intelligence, imagination, creativity, knowledge of a subject, a deep insight into the nature, attributes and constraints of the medium, its language, grammar and techniques and above all the ability and willingness to work in a team.

The felicity of the language and the skill to convert simple ideas into powerful aural (audio) experiences and/or to transform abstract ideas and concepts into visual illustrations and appropriate analogies, are other important traits of scriptwriters of educational audio and video programmes.

Developing scripts for radio/audio programmes

Writing for radio differs from other forms of writing such as 'writing for print' or 'television'. The reasons are given as follows:

- In radio/audio writing, words are required to be spoken and heard (not required to be read).
- Unlike a television or film viewer, the radio listener only hears the speaker (but does not see him/her).
- The potential listeners, especially those targeted in open schooling and distance learning systems, comprise of all ages and conditions and have vast variations in their levels of understanding, achievement and intelligence. In this case, therefore, the audio/video writer must use the simplest possible language and avoid long, usual and bombastic words and sentences. In other words, we may say that the educational radio/audio writer must learn to:
 - Write for the ear, not the eye,
 - Write for speaking, not for reading,

The final script, as described above, is ready for recording at this stage. The radio producer will arrange all studio facilities and production resources, crew and artists to produce and record the programme for broadcast or playback.

The educational audio script, in its final form, must indicate all relevant instruction in CAPITAL LETTERS so that these are not mistaken for a 'dialogue to be spoken'. Instruction on the script can also be underlined, as these are not to be spoken by actors or performers. Such instructions must be noted and followed both by the artists and the production crew.

Developing scripts for TV/video programmes

Writing for television or video is a kind of visual scripting. It is just not an activity or coordinating words with pictures in sequential continuity. It requires intelligence, creativity, drawing capability, knowledge of the medium, its nature, language, grammars and techniques.

Television or video is primarily a visual medium. That means it is the visuals or pictures that come first, and are the main carriers of messages. Words do have their place but only in support of the visuals. Many a time, pictures need no words; they speak for themselves and make powerful statements. A TV/video scriptwriter has, therefore, to learn to think in terms of visuals, visual ideas and visual illustrations for ideas.

In television, a writer has to communicate in an entirely new language: in which the writer uses the video camera as his/her and all the different kinds of shots, movement devices, techniques, effects, transitions, dialogues, sounds, noises and even silences as his/her language. Writing for TV/video is thus quite different from other forms of writing particularly 'writing or print' or 'writing for radio'.

Writing as such is a solitary activity. However, writing for television or video is largely a co-operative effort; a team mode approach. It may be seen as a sort of a continuous dialogue or a constant interaction among the scriptwriter, the researcher, the subject specialist, the producer and other members of the production team. This dialogue or interaction generally begins with a 'programme idea' or a 'programme topic' or a 'theme' around which a video script is proposed to be evolved and continuous up to the end when there is no time left and the programme script has got to be finally produced. While the scriptwriter is the principal architect of the script other team members contribute in many different ways to its instructional effectiveness, authenticity, visual quality, technical perfection and overall embellishment. To put it differently, we can say that video or television scripts are evolved step by step. Creatively, imagination and cooperative effort are the key words in the video scripting process.

Process of TV/video scriptwriting

It is rather difficult to describe what the video scriptwriting process like. Experiences vary from writer to writer and from script to script, and it is very hard to generalize. However, television./video scriptwriting may be seen as consisting of a series of steps or stages or processes which together and often overlap. But the basic pattern of the scripting and programming processes remain almost the same. All TV/video scriptwriters, whether

Give adequate attention to the beginning of your programme. The first sentence or the open of the programme. The first sentence or the open of the programme must be interesting and should hold the listeners attention. Thereafter, you may follow it with other key points and ideas linking them together in a sequence that you already decided above. Join each sequence by signposts of aural indicators, which will help draw the listener's attention and move from one point to the other.

After you have dealt with all key points in your script, spend some time on finding a good of your programme. In educational radio, it is a good idea to return to the introductory remark end the programme reinforcing the same point. There can be several other interesting way round off our pgoramme. For example, you may choose to leave your listeners with a spy theme, a punch line, a particular action or task. The programme must close on a positive me and in natural way – not in an abrupt, sudden or unnatural fashion. Openings and closing although most difficult to visualize and write certainly make radio programmes a memorable experience for the listeners.

Check and rewrite

Write the draft script in your hand, it is now time to shape the final script. It is the good idea I discuss the draft script with some of your colleagues or media experts to get their reaction suggestions and incorporate the same in the revised version of the script. Now, read you're to yourself and ask the following type of questions:

- Is the script interesting? (If not, change it.)
- Is it easy to understand? (If not, replace difficult words and expressions with simple and straight ones.)
- Is it accurate and authentic in information and content? Is it free from controversies that may invite criticism or an objection later? (If not, update it.)
- Are there too many facts and details? (If yes, reduce and simplify.)
- Is it logically sequenced? (If not, alter the sequences accordingly.)
- Does the content match with the given objectives? (If not, modify the content.)
- Does it have enough 'signposts' for joining different key points? (If not, add more.)
- Does it begin and end with a punch or memorable sentence? (If not, add think more and modify.)
- Is the language conversational so as to engage the listener in a one-to-one interaction? (Remember that it will be
- Are the sentences and phrases short and simple to understand and speak? (Modify to remove tongue twisters and bombastic words and phrases.)

As you answer the above kind of questions to yourself, you must try to revise, refine and rewrite your script into the final form. One golden rule to test eh quality of your script is to read it out aloud to yourself – speaking reach sentence one, twice, thrice, exactly in the same way you would like it to be heard. In this way, you can modify, rearrange, refine and polish your language and ideas on the basis of your own feedback and judgment. You may add some more attention-catchers in your script, if you find the need to do so at this stage,

A well-designed programme brief delineates the parameters of the proposed video script and enables the scriptwriter to begin the process of programme research. Programme research is the most essential pre-requisite for developing a video script. It is at this initial stage that the scriptwriter must plan and carry out thorough research both on the topic as well as the target audience. He/she should look for suitable visual materials and other interesting and related information on the topic. Not only should she/he consult books, journals, census reports, yearbooks and encyclopedias but should also talk to experts and knowledgeable people in that particular field.

At this stage, it is important for the scriptwriter to get to know the target audience well - their background, maturity level, interests, likes, dislikes preferences etc. Such knowledge about the audience enables the scriptwriter to collect, select and organize relevant programme materials and information in a manner most interesting for the viewers. It is not uncommon for writers and researchers interact with small groups of their target audience and know their first-hand experiences and interests on the topic. Some writers do not attach much importance to programme research and tend to skip this step, often claiming, that they already know a lot about the topic and the audience. It is, however, a grave misconception and must be guarded against.

Selection of content

During programme research, the writer is often able to come across a large mass of material and information (both written and verbal) besides pictorial evidence on the programme topic. At this stage, therefore, he/she must go through this mass of materials and select the most relevant material, visual resources and information which match the programme objectives, are relevant to audience needs and interests and are sufficient to cover the given content and fill programme time most appropriately.

To put it conversely, the scriptwriter must eliminate what is not relevant to programme objectives or is not likely to click with the viewers or may go over-their heads, or may even unnecessarily lengthen the programme and increase its information size.

Message planning

Message planning is the most decisive and creative stage of video script development. Here, the scriptwriter explores interesting ways of dishing out his/her programme to the audience. Many options and considerations come into sharp focus and the writer has to design a strategy taking appropriate decisions on each of the following aspects:

- Identifying key teaching concepts or ideas to be highlighted.
- Selecting a suitable format or a combination of formats for presenting the programme.
- Adopting a particular programme style and approach.
- Exploring media possibilities; use of visual examples and analogies, graphics, photographs, reality bites, stock shots, animation, experiments, demonstrations and other resources, both visual and aural.

consciously or unconsciously, go through these stages or steps in one way or the other. The sequence and timing of these steps may vary and even overlap in most of the cases.

Major steps of TV/video scriptwriting process

A descriptive presentation of the steps involved in the video scriptwriting process suggested below may be helpful to you. Certainly it is a loose, flexible and arbitrary arrangement. Yet this process framework will give you sufficient insight into the creative activity of TV/video scriptwriting.

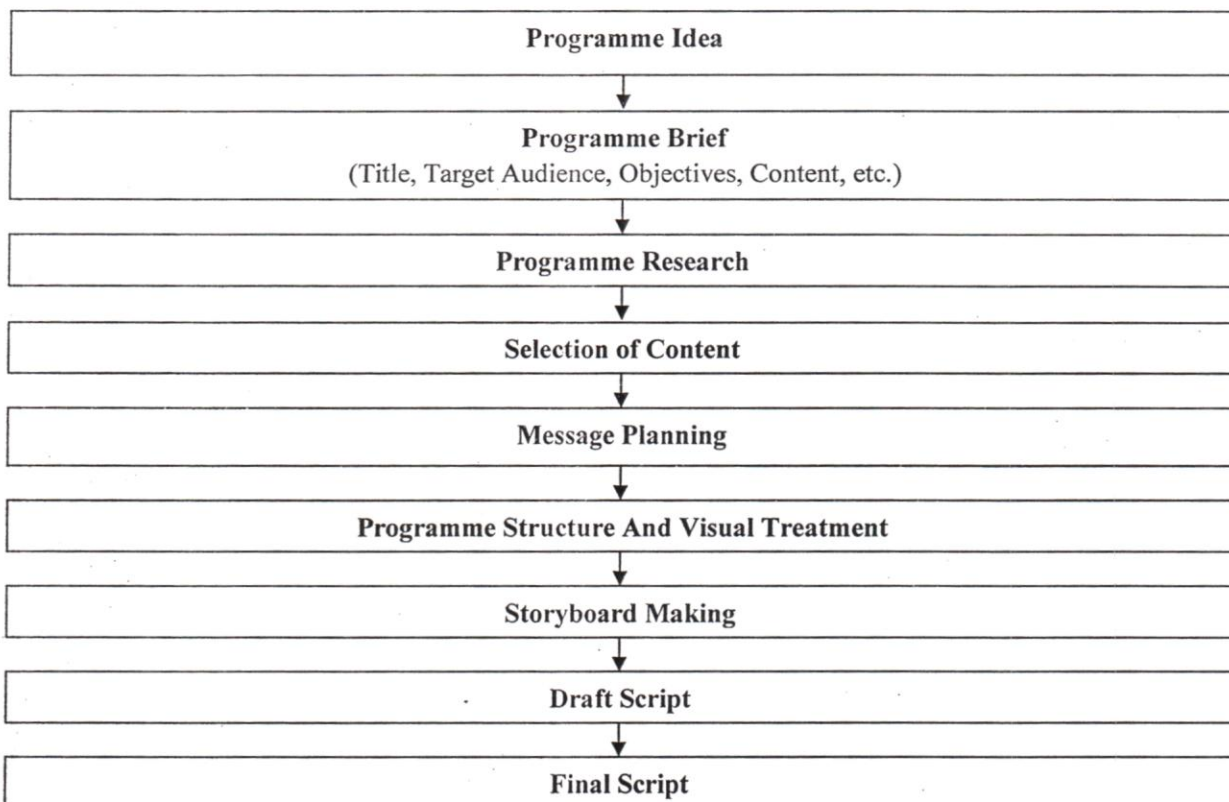

Programme ideas

Ideas are basic to any kind of writing, not just television writing. Indeed, all educational TV/video scripts originate with an idea. Once an idea or a theme has been identified, it needs to be analyzed for its possible expansion into a worthwhile visual presentation. If the idea is found to be entertaining, educative and appropriate for the intended audience and suitable for television presentation, it meets the criteria for being 'production worthy'.

Programme brief

Once an idea or a theme or a topic is adjudged as 'production worthy' for TV/video production, it can be further analyzed and expended into a 'programme brief' or an 'academic note'. As already discussed, a programme brief is the first written statement-which forms the basis of an educational video script. It provides a road map to the scriptwriter.

Programme research

- How will they feel and react to a particular visual sequence or a part of it?

In this process, the writer must again think of and provide for visual illustration and analogies for abstract ideas and key concepts proposed to be presented in the programme. Different sequences of the script should be arranged in a logical and natural order so that they appear to be evolving from one sequence to the other. The writer must also think of and decide on possible visual and/or aural links or transitions from one sequence to the other. It is very helpful to draw a 'timeline' showing how much time should be devoted to each sequence keeping in view: (i) the coverage of the content, (ii) weightage or emphasis on programme objectives and key teaching points, and (iii) the attention span of viewers. Some scriptwriters, especially those who write for young children, draw up an 'interest curve' or a 'tension chart' to ascertain uninterrupted attention of viewers.

Storyboard making

The storyboard means a detailed, shot-by-shot description of the programme on sheets of paper divided into two vertical columns. The rectangular boxes (3:4) in the left hand column are used for drawing pictures/sketches with shot sums described on each; and the right hand column is used for writing supporting words, sound effects and music, as shown in Figure 2.2.

A STORYBOARD OUTLINE



Fig. 2.2 A suggestive outline of a storyboard for a video script

The storyboard is important because:

- It forces the writer to think in terms of visuals.
- It is at this stage the TV/video script begins to appear as evolving into a series of pictures with sequential continuity, with sound and action described side by side.
- It is easily possible to study the overall development and progression of the script with the use of the storyboard.
- It is possible and advisable to make script changes, if any, by adding, deleting, shifting or reordering of shots and sequences.
- It is useful for all production team members to study the storyboard.

- Choosing a definite storyline for message presentation: using human characters in the story - men, women, children, presenter, anchor, puppets, cartoon figures, animals, birds etc.

While deciding on the above aspects, as suggested earlier the writer must always keep in view: (i) the nature and requirements of the topic or the subject, (ii) viewers' age, characteristics, needs and interests, (iii) programme objectives, and (iv) a balanced presentation of the given content in an interesting way.

Programme structure and visual treatment

Programme structuring is the creative process of giving the programme a definite shape and form. It is at this stage that the programme begins to unfold its shape or structure with a clear-cut storyline with a beginning, a middle and an end. Here, the scriptwriter must give some thought to such questions as:

- How will the programme begin? (or what will be the first or introductory sequence of the programme?)
- How will the programme end? (or what will be the concluding sequence of the programme?)
- What will be the shape and Order of the sequences that will form the middle part (or the body) of the programme?
- How many sequences will the programme finally contain? And in what order?
- What will be the length, sequence, emphases and amount of educational content of each of the sequences?
- Does the content of each of the sequences contribute to and match the programme objectives set out in the beginning? If yes, to what extent? If .not, how can content and objectives be matched optimally?

While finding solutions to such questions as noted above, the writer must rethink of a good beginning for the programme. Most often, it is the introductory sequence which holds the attention of the audience and keeps their motivation high for receiving the rest of the programme. On the contrary, however, if the beginning is uninteresting and dull, the programme may fail to click with the viewers.

The scriptwriter should also devote some time to think about a good natural ending for the programme. Viewers invariably tend to like and remember for long a programme that ends on a cheerful and satisfying note and provokes them to think and act in the desired way. Rest of the sequences that constitute the middle part or the body of the programme, must also receive writer's attention in the same way - arranging the visual and aural content logically and meshing it with the given objectives.

As the programme structure takes a definite shape, the writer has to work out simultaneously a detailed visual treatment for different sequences of the programme. The visual treatment must provide at each step a full description of:

- What will the viewers see?
- What will they hear?
- What will they think?

SOURCES

e-Pathshala

National Repository of Open Educational Resources (NROER)

e-pgpathshala

Gyanpitara

Karnataka Open Educational Resources (KOER)

The Open Educational Resources universitas (OERu)

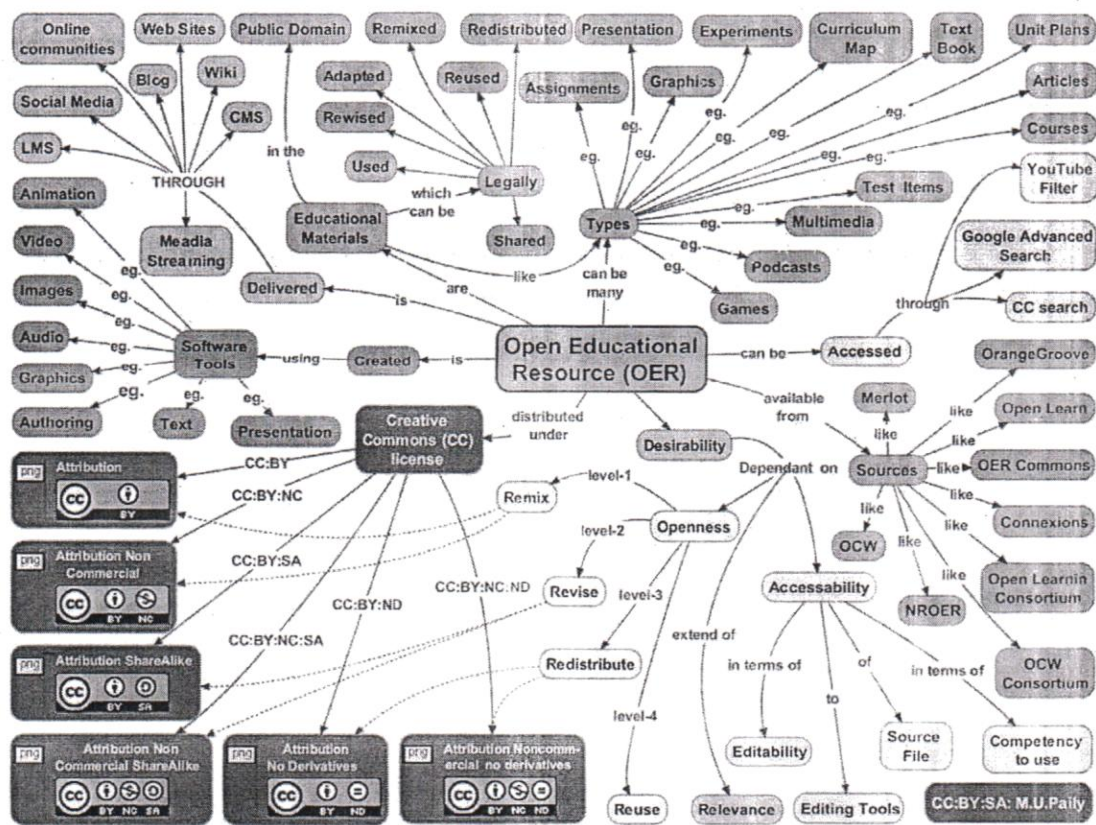

A suggestive outline of a storyboard for a video script

The story board is important because:

- It forces the writer to think in terms of visuals.
- It is at this stage the TV/video script begins to appear as evolving into a series of pictures in sequential continuity, with sound and action described side by side.
- It is easily possible to study the overall development and progression of the script with the use of the storyboard.
- It is possible and advisable to make script changes, if any, by adding deleting, shifting or reshaping of shots and sequences.
- It is useful for all production team militias to study the storyboard.

Some experienced TV Scriptwriters skip the storyboard stage and straightway prepare a draft script. For beginners, however, storyboard Making is immensely useful and is strongly recommended. Let's at this stage describe a little more about a draft script and the final script.

Draft script

The storyboard, when complete, at once road to the preparation of a draft script. The draft script is the first full length script that includes a complete listing and description of all visuals, captions, accompanying commentary, dialogues, actions, movements, music, sound effects and any kind of pre-recorded inserts or audio/video inputs. The draft script must be shared and discussed with all team members, experts as well as the producer to get their reactions and suggestions on various aspects. The scriptwriter must be open to criticism and ideas fur improvement of the Script should be welcomed.

Final script

At the final script stage, the writer incorporates all suggestions made at the stage of the draft script. This stage suggests that the scriptwriter has more or less finally accomplished his/her job. In most cases, he/she hands over the script to the TV producer. As the scriptwriter usually bows out at this stage, the producer and his/het team take over. However, the interaction between the scriptwriter and the producer and other team members must continue up to the point the programme has been finally produced.

From the above description, it may be amply clear that video scriptwriting is a co-operative activity. It is not just a process of writing words and sentences and thinking of pictures to accompany them or vice versa. TV/video scriptwriting is indeed a highly creative process. Video scripts are evolved bit by bit, rather than written. That is why each video programme is unique Milts message, design, format, style and technique. In all cases, however, a video scriptwriter must go through all the stages and processes of script development as described above.

12.8 REFERENCES

1. COL (2005). Creating Learning Materials for Open and Distance Learning: A Handbook for Authors and Instructional Designers. Commonwealth of Learning available at <http://oasis.col.org/bitstream/handle/11599/43/odlinstdesignHB.pdf?sequence=1&isAllowed=y>
2. Editing Software - Edit Audio, Video, Photos or Graphics www.nchsoftware.com/software/editing.html
4. e-Learning Standards - Course Avenue available at www.courseavenue.com/e-learning-standards accessed on 19th Jan, 2016
5. Free and Open Source Authoring Tools for e-Learning-eFront Blog available at <http://www.efrontlearning.net/blog/2010/10/open-source-authoring-tools-for-e.html> accessed on 19th Jan, 2016
6. 'Frequently asked questions- Creative Commons' Available at https://wiki.creativecommons.org/index.php/Frequently_Asked_Questions accessed on 12th Jan, 2016
7. National Repository of Open Educational Resources(NROER) Available at <http://edtechreview.in/news/561-national-repository-of-open-educational-resources-by-mhrd> accessed on 13-1-2016
8. Proprietary software - Wikipedia, the free encyclopedia available at https://en.wikipedia.org/wiki/Proprietary_software accessed on 18th January 2016
9. SOM Naidu 'E-learning A Guidebook of Principles, Procedures and Practices' Published by CEMCA 2003.
10. 'Standards for e-learning' available at http://www2.tisip.no/quis/public_files/wp5-standards-for-elearning.pdf accessed on 17-1-2016
11. The Enhancement of Reusability of Course Content---org Available at www.ejel.org/issue/download.html?idArticle=148 accessed on 18th January 2016
12. Standards for e-learning Available at http://www2.tisip.no/quis/public_files/wp5-standards-for-elearning.pdf accessed on 19th Jan, 2016
13. VUSSC. Training Educators to Design and Develop ODL Materials A Facilitator's Guide, Virtual University for Small States of the Commonwealth available at http://oasis.col.org/bitstream/handle/11599/458/Training%20Educators%20to%20Design%20and%20Develop%20ODL%20Materials_2.pdf?sequence=2&isAllowed=y

Sound

Kalpana Maski
Assistant Professor, RIE Bhopal

Sounds are all around us—cars honking, phones ringing, friends talking, and dogs barking are all sounds you are probably familiar with. So, what is sound? Sound is a type of energy made by vibrations.

Introduction

Sound is a longitudinal, mechanical wave. Sound can travel through any medium, but it cannot travel through a vacuum. There is no sound in outer space. Sound is a variation in pressure. A region of increased pressure on a sound wave is called a compression (or condensation). A region of decreased pressure on a sound wave is called a rarefaction (or dilation). The speed of sound depends upon the type of medium and its state. It is generally affected by two things: elasticity and inertia.

Key concepts:

1. Form of energy: transfer from one point to another with the help of particles of the medium.
2. Exert pressure on a wave
3. Humans are generally capable of hearing sounds between 20 Hz and 20 kHz
4. Simple harmonic waves
5. Echo and resonance are the examples of forced vibrations.

Prior Knowledge:

The student

1. give the location of a sound
2. describe source of sound as the vibration of matter, including air
3. describe and demonstrate with vibrating objects how sound travels through substances by wave motion
4. had an opportunity to experience or talk about an echo
5. compare and contrast music and noise using concepts of rhythm, pitch and volume related to wave motion
6. worked with forms of matter such as a solids, liquids and gases
7. describe the human voice range as related to frequency
8. worked with examples of at least two forms of energy, such as light and heat

Instructional strategy:

The concept of sound will be explained with the help of demonstration of different activities, examples, models, charts, animations, slide-show etc and the previous knowledge of the students.

Activity

These three activities will help us examine vibrations, how sounds develop and characteristics of sounds.

The students

1. Strike a tuning fork and then put it on their hands to sense the vibrations. The students try to discover how to make the tone louder. Ask students if they think they can change the tone. The students describe the tuning fork as they felt it on their hands.
2. Place a meter stick with one end extending at least 15 cm. over a table and hold it firmly on the table with one hand. Students pluck the protruding end of the meter stick to make a sound. They determine what the meter stick is doing as it makes a sound.
3. Experiment with the meter stick, trying to make high and low and loud and soft sounds. They record their observations for future use.

Ask students to tell what they think sound is. Sound develops when something is vibrating — when it is moving back and forth. Hold a loose rubber band between your fingers and thumb and pluck it gently. Ask the students: Is it making a sound? Why not? You are right. It has to move back and forth — vibrate very fast — for us to hear the sound.

The vibration of matter causes all sounds. Sound is very important in our lives. Sound can make us happy, as with music, dancing or playing a musical instrument. However, sound can be harmful when it is too loud. Sounds can also warn us of danger, as with a fire siren. Sometimes when we are home alone, the sound of the radio or television can give us comfort.

Discuss each activity with the students, stressing that sounds develop in many ways as vibrations in matter.

A wave is a disturbance or oscillation that travels through space and matter, accompanied by a transfer of energy. Wave motion transfers energy from one point to another, often with no permanent displacement of the particles of the medium—that is, with little or no associated mass transport. They consist, instead, of oscillations or vibrations around almost fixed locations.

Sound Waves (~ any longitudinal wave)

A sound wave is similar in nature to a slinky wave for a variety of reasons. First, there is a medium that carries the disturbance from one location to another. Typically, this medium is air; though it could be any material such as water or steel.

A sound wave is a longitudinal wave in an elastic medium (which could be a gas, liquid or solid). In such a wave the particles of the medium oscillate back and forth along the direction in which the wave travels such that regions of high and low density are created. It is these regions of compression and rarefaction which make up the wave fronts which travel through space and carry energy.

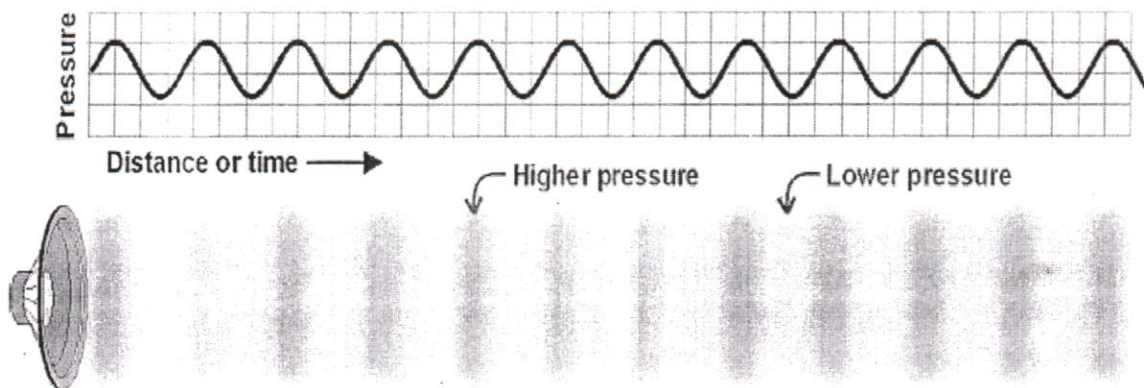

The waves have a speed which comes from the elastic properties of the medium. When a molecule moves, it collides with the next one and makes it move too. The energy of a sound wave travels away from the source through a series of molecule collisions parallel to the direction of the wave. Sound cannot travel through a vacuum.

Sound waves can also travel through liquids and solids. The velocity of a sound wave depends on the temperature of the medium and its elasticity (more elasticity means that molecules will move easily). **Through air, sound waves travel at 343 m/s.** Actually, sound waves move faster through liquids and solids than through gases.

Some basic definitions:

1. **Vibration**

One complete round trip of a simple harmonic motion is called vibration.

or

If a body in periodic motion moves to and fro

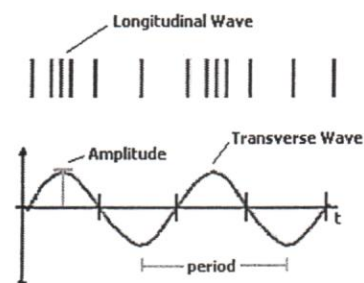

over the same path, this motion is called Oscillation.

2. **Wave:** A method of energy transfer involving some form of vibration is known as a wave.
3. **Wave Motion:** Wave motion is a form of disturbance, which travels through a medium due to periodic motion of particles of the medium about their mean position.

Experiment

We see that if we dip a pencil into a tub of water and take it out a pronounced circular ripple is set up on the water surface and travels towards the edges of the tub. However if we dip the pencil and take it out many times, a number of ripples will be formed one after the other.

Waves can also be produced on very long ropes. If one end of the rope is fixed and the other end is given sudden up and down jerk, a pulse-shaped wave is formed which travels along the rope.

4. **Transverse Wave:** The wave in which amplitude is perpendicular to the direction of wave motion is known as Transverse Wave.

Examples

- * Radio Waves
- * Light Waves
- * Micro Waves
- * Waves in Water
- * Waves in String

5. **Longitudinal Wave:** The wave in which amplitude is parallel to wave motion is called longitudinal wave.

Examples

- * Sound Waves
- * Seismic Waves

6. **Time Period (T):** The time required to complete vibration is known as time period.
7. **Frequency:** It is the number of vibrations executed by an oscillating body in one second. It is measured in Hertz or cycles per second
8. **Displacement:** It is the distance of a vibrating body at any instant from the equilibrium position.

9. **Amplitude:** The maximum distance of the body on either side of its equilibrium position is known as amplitude.
10. **Wavelength:** The distance between two consecutive crests and troughs is called wavelength. It is measured in meter.
11. **Natural Frequency:** The frequency at which an object will vibrate freely (without any external periodic force or resistance) is known as natural frequency of that object.
12. **Audible Sound:** Our ear can hear only those sounds whose frequency is between 20Hz and 20000Hz. This range is known as audible sound.
13. **Ultrasonic Sound:** Sound with frequency greater than 20000 Hz is known as ultrasonic sound.
14. **Interference of waves:** When two or more waves with the same frequency reach the ear, the ear interprets these waves as one wave with amplitude as big as the sum or difference of the initial waves.
15. **Octave:** The interval between a waveform and another of twice the frequency is known as Octave.
16. **Simple Harmonic Motion (S.H.M):** To and fro motion of a body in which acceleration is directly proportional to displacement and always directed towards mean position is known as Simple Harmonic Motion.

Condition for S.H.M: The conditions for simple Harmonic Motion are given below:

- * Some resisting force must act upon the body.
- * Acceleration must be directly proportional to the displacement.
- * Acceleration should be directed towards mean position.
- * System should be elastic.

Examples

Following are the examples of S.H.M:

- * Body attached to a spring horizontally on an ideal smooth surface.
- * Motion of a simple and compound pendulum.
- * Motion of a swing.
- * Motion of the projection of a body in a circle with uniform circular motion.

Sound

A vibration transmitted by air or other medium in the form of alternate compressions and rarefactions of the medium is known as Sound.

Production of Sound

Sound is produced by a vibrating body like a drum, bell, etc, when a body vibrates due to the to and fro motion of the drum, compressions and rarefactions are produced and transmitted or propagated in air.

Propagation of Sound Waves

When a body vibrates in air, it produces longitudinal waves by compressions and rarefactions. These compressions and rarefactions are traveled by the particles of the medium and transferred into the next particles. Due to this transference, sound propagates in a medium.

Experiment

Suspend an electric bell in a jar by its wires through a cork fixed in its mouth. Switch on the bell; we will hear the sound of the bell. Now start removing air from jar with the help of an exhaust (vacuum) pump. The sound will decrease, although the hammer is still seen striking the bell. This experiment shows that air or any other medium is necessary for the propagation of sound.

Activity

Understanding sound as vibrations

Put rice on a drum, when you strike the drum the rice will dance because of the vibrations (Title – Have you ever seen rice dance?)

Voice vibrations

Put two fingers on your throat and then talk, you will feel the vibrations from your voice box.

Velocity of Sound

It is a matter of common experience that the flash of lightning is seen earlier than hearing the thunder of cloud. Similarly when a gun is fired its sound is heard a little after seeing its flash. The reason is that light is faster than sound. Due to its slow velocity sound lags behind.

Factors Effecting Velocity of Sound

The factors are given below:

- * Velocity of air or any other medium.
- * Density of the medium.
- * Temperature of the medium.
- * Nature of the medium

Characteristics of Sound

The characteristic properties of sound by which we can distinguish between noise and music, shrill and grave sounds or sound of men and women are known as characteristics of sound. The properties of sound are given below:

A. Loudness

Loudness is the magnitude of auditory sensation produce by sound. Intensity can be defined as the energy carried by the sound waves through a unit area placed perpendicular to the direction of waver per second.

Factors Effecting Loudness of Sound

Loudness depends on following factors:

- (i) **Area of Vibration of Body:** Greater will be the surface area more will be the loudness.
- (ii) **Amplitude of Motion of Vibrating Object:** Greater will be the amplitude, more will be the loudness.
- (iii) **Density of Medium:** Loudness is directly proportional to the density of medium.
- (iv) **Motion and Direction:** If source of sound is moving towards the listener loudness will be greater or if wind supports the velocity of sound the loudness will be greater.

B. Pitch

The sensation that a sound produces in a listener as a result of its frequency is known as Pitch. This is the property of sound by virtue of which we can distinguish between a shrill and grave sound.

Factors Effecting Pitch of Sound

Pitch depends on following factors:

- (i) **Frequency of Vibrating Body:** The greater the fundamental frequency, more shrill will be the sound.
- (ii) **Relative Motion of Sound:** If source and listener both are coming closer pitch will increase.

Activity

Make a glass xylophone

Find four glass beakers which are the same size and shape. Fill one beaker with water almost to the top. In the second beaker make the water level about 2 cm from the top of the glass. In the third beaker, make the level 4cm from the top. Don't put any water in the fourth glass.

Tap the side of each glass with a wooden spoon. Each glass will ring with a note of a different pitch (more water the lower the pitch.)

C. Quality or Timbre or Tone

The characteristic of a musical note that is determined by the frequency present is known as Quality or Timbre or Tone of that sound. This is the property of sound by virtue of which it is possible to identify a sound of the same loudness and pitch but originating from different instrument.

Factors Effecting Quality

Quality depends upon the following factors:

- (i) Phase of the Sound Wave.
- (ii) Shape of Waves

D. Intensity of Sound

The rate at which a wave's energy flows through an area ($I=P/A$). It is measured in decibels.

Factors affecting Sound Intensity

Sound intensity depends on

- (i) the strength, or amplitude,
- (ii) the vibrations producing the sound
- (iii) Distance from source

Normal sounds carry small amounts of energy, but our ears are very sensitive. Human can hear sounds with intensities as low as 10^{-12} W / m^2 . This is called the threshold intensity, I_0 , i.e.

$$I_0 = 10^{-12} \text{ W / m}^2$$

The Decibel Scale (1/10th of bel):

The decibel (abbreviated dB) is the unit used to measure the intensity of a sound. On the decibel scale, the smallest audible sound (the threshold of hearing) is 0 dB. The decibel (dB) is a logarithmic unit used to express the ratio between two values of a physical quantity (usually measured in units of power or intensity). A decibel (dB) is one tenth of a bel (B), i.e., 1B = 10dB.

$$\text{Intensity level} = 10 \log_{10} (I_1 / I_0) \text{ (dB)}$$

The decibel is also commonly used as a measure of gain or attenuation, the ratio of input and output powers of a system, or of individual factors that contribute to such ratios. The decibel is used for a wide variety of measurements in science and engineering, most prominently in acoustics, electronics, and control theory.

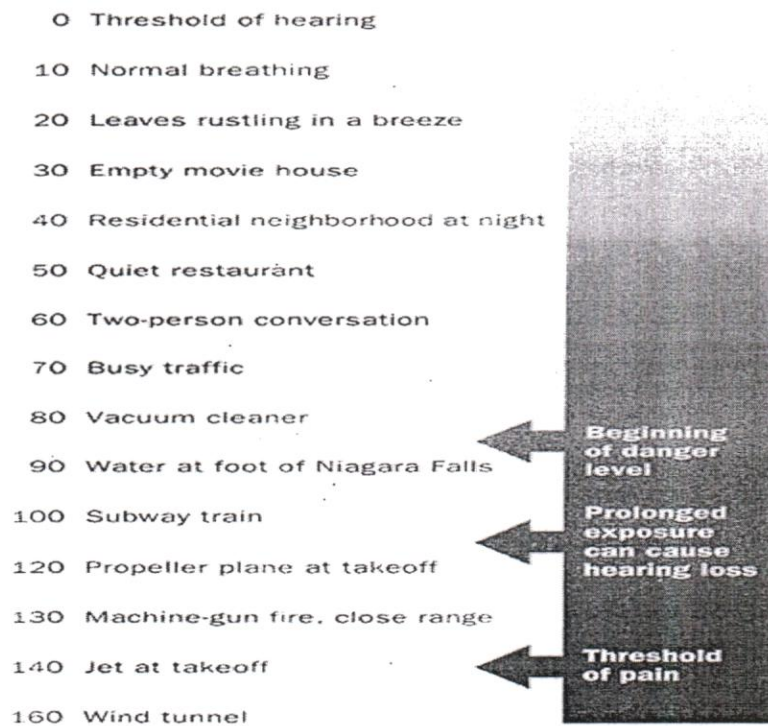

Reflection of Sound

Sound waves encountering a surface and follows laws of reflection.

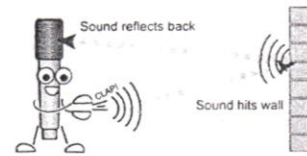

Echo: An echo is simply a reflected sound wave. The word *echo* derives from the Greek ἠχώ (*ēchō*), itself from ἦχος (*ēchos*), "sound". It is the phenomenon of repetition of sound of a source by reflection from an obstacle. It is more commonly used for the special branch of that PHYSICS that deals with the construction of enclosed areas so as to enhance the hearing of speech or music. Reflection of sound off a surface (**Acoustics** (Greek *akouein*, "to hear")). For echo $T = 2d/v$.

Production of echo:

Typical examples are the echo produced by the bottom of a well, by a building, bell or by the walls of an enclosed room and an empty room. A true echo is a single reflection of the sound source. An echo is produced when sound waves bounce off of another surface. It is the second sound produced after reflection of sound waves on a rigid object.

Condition for formation of echo:

1. The size of the obstacle/reflector must be large compared to the wavelength of the incident sound (for reflection of sound to take place).
2. The distance between the source of sound and the reflector should be at least 17m (so that the echo is heard distinctly after the original sound is over.)
3. The intensity or loudness of the sound should be sufficient for the reflected sound reaching the ear to be audible. The original sound should be of short duration.

Use of echo: Use of echo by Bats, dolphins, fisherman (SONAR) and in medical field.

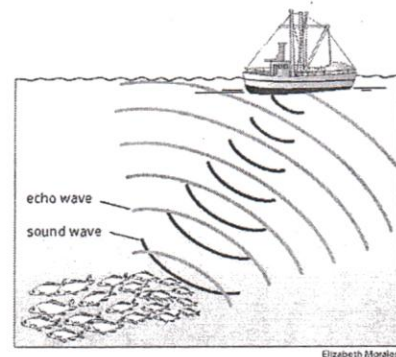
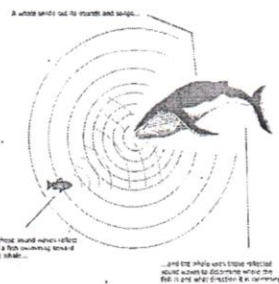
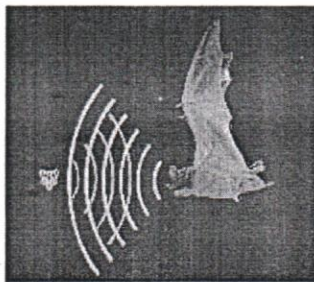

Resonance

The large amplitude vibration of an object when given impulses at its natural frequency is known as Resonance.

Experiment

Consider a long string stretched tightly between two pegs. Four pendulums A, B, C and D of different lengths are fastened to the string. Another pendulum E of same length as A is also fastened.



When pendulum E is set to vibrate, it will be observed that all the pendulums start to swing but pendulum A begins to vibrate with larger amplitude, as pendulum E is set into vibration. It imparts its motion to the string. This string in turn imparts the same periodic motion to the pendulums. The natural frequency of all other pendulums except A is different. Due to the same natural frequency only A vibrates as the same vibration of E. This phenomenon under which pendulum A begins to vibrate is called resonance.

Example

March of Soldiers while crossing the Bridge: Each bridge has its own natural frequency and marching of soldiers is another vibrating system. So there may occur a force on vibration in bridge. This may damage the bridge. So, for safely precautions, it is written that soldiers must march out of step while crossing the bridge.

Dopplers Effect:

The apparent frequency of a sound changes due to the relative movement of the source and/or observer. The Doppler effect – the change in pitch due to a moving wave source.

1. Objects moving toward you cause a higher pitched sound.
2. Objects moving away cause sound of lower pitch.
3. Used in radar by police and meteorologists and in astronomy.

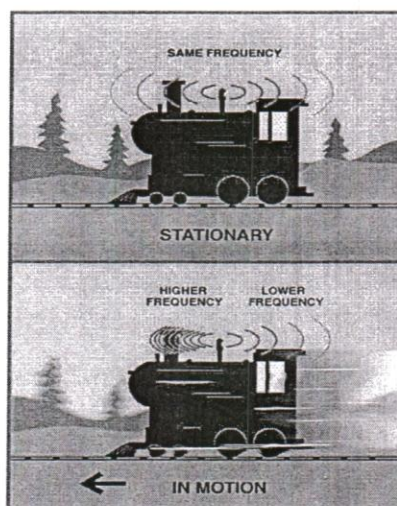

Harmful Effects of Sound (Noise)

Nowadays noise is considered as a great pollution, which is very dangerous for us. Some of them are as follows:

- * Continuous noise damages hearing and can result in complete deafness.
- * Noise has become a great cause for depression and blood pressure.
- * Mental system shows less efficiency due to noise.
- * Consequently it is harmful in all respects for living body.

Musical Sound: The sound producing pleasing effect on our ears is called musical sounds.

Discussion Questions:

1. Hypothesize what happens to sound waves when they reach a wall or other solid, flat object.
2. If sound can't travel in space, hypothesize what other modes of communication astronauts can use when they are outside the space shuttle?
3. Explain why, based on the behavior of sound waves, a classroom with a tile floor is louder than a library that is carpeted?
4. How does sound travel when you have a conversation with your friends?
5. Think about what it is like to hear things under water. Debate whether sound travels better in liquids (like water), gases (air), or solids (like putting your head down on a desk and having someone slam a book down on the surface)?
6. Discuss why you see lightning before you hear thunder during storms.

Chemical Reactions and Equations

Prof. I.P.Agrawal

Ex Professor NCERT

Need/Needs expressed where difficulty is encountered in transaction:

- (i) Displacement Reactions
- (ii) Double Reactions
- (iii) Redox Reactions Electronic Concept in terms of gain/loss of electrons by the species:
- (iv) Exothermic and Endothermic Reactions

Appropriate Material for Expressed Needs. Before dealing with above mentioned transactional difficulties, it would be worthwhile to first understand by the learners what is chemistry and what is its importance for the humanity. In simple words we can say that chemistry deals with varieties of matter and change of one kind of matters into the others. For example air itself which is a mixture of several components has three very important varieties of matter contained in it namely H₂O, (as vapours), O₂ and CO₂ present in varying amount. Now carbon dioxide present in air combines with waters vapours in the air to produce carbohydrate (food for the plants) and oxygen. As chemistry has its own language to express the above interaction, which most appropriately be written as:-

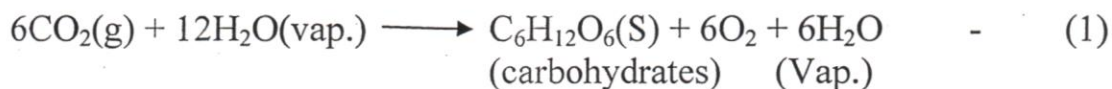

[Remember that this reaction should not be oversimplified by writing 6H₂O species on reactants side and indicating no H₂O on products side. Discussion on this issue we postpone at this stage. We will take this at a later stage]. Two more

examples are worth considering here for the change of one kind of matter into the other who are immensely connected with our daily life. These reactions are the decomposition of calcium carbonate and burning of hydrocarbon in the kitchen. In terms of the language of chemistry, these reactions may be written as:

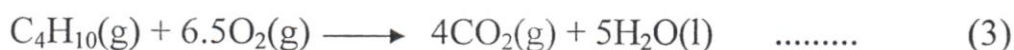

(Mainly present in LPG)

At this stage now we may assess the importance of all the three reactions in our daily life situations. Reaction (1) definitely benefits us to lessen the concentration of CO_2 in the atmosphere, whereas the reaction (2) is of great importance for cement industry, as CaO is the major constituent of cement (a material which finds use in construction work) and reaction (3) is a source of energy for cooking food in the kitchen. If we reassess these three reactions, we find that reaction (1) occurs in plants, which are source of many materials for our survival. Reaction (2) is of great importance for construction work of the buildings which are not possible to erect without cement and reaction (3) is a source of energy; and this energy we utilize for various purposes.

In all the above situations, the nature and the identity of initial substances have changed. This we know is a criterion value of chemical change (which the part of chemistry) and the way we represent the change is called chemical equation or equation and the equation in which number of atoms of different elements on both sides of the arrow is the same is termed as a balanced equation. At this stage the following aspects have only come to highlight and these are:-

- (i) Nature of Chemistry
- (ii) Representation of chemical change through equation
- (iii) Balanced chemical equation

Let us consider few more reactions that we come across in daily life, these are:

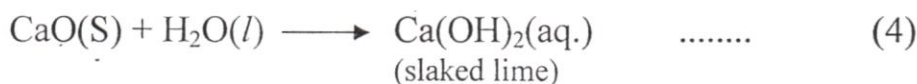

(The reaction we encounter when so oftenly we need whitewashing in own house)

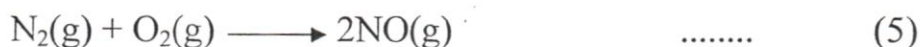

[The chemical change that we encounter during thundering in the sky and which is the thrust reaction for nitrogen cycle in nature]

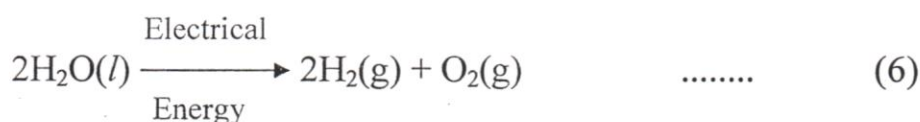

Whereas reaction (4) and (5) are referred to as combination reactions, reactions (2) and (6) are designated as decomposition reactions.

In simple language it can be said that when two or more substances combine to form a single product, the reactions are called combination reactions conversely when a single substance under appropriate condition breaks down to give two or more substances then the reactions are known as decomposition reactions consider the reaction:



(What would you like to tell this now?)

You may also practice these decomposition reactions in the laboratory by decomposing the following components.

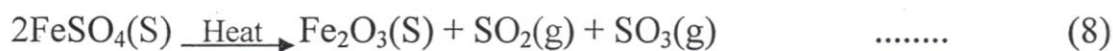

[What criteria you would adopt to label reaction as chemical reaction in each case?]

Apart from combination and decomposition reactions we come across with other types of reactions also. Two such distinguishing reactions are displacement and double displacement reactions. To comprehend these, carry out the following activities.

Activity-1:

Take three metal sheets of iron, zinc and lead and place each of these in copper sulphate solutions copper chloride solution as the need be. Wherein copper sulphate solution is held in a small beaker of capacity 100 mL. Let each of the sheet be held in the copper sulphate solution for about 30 minutes and afterwards observe with respect to the following points:

- (i) Deposit if any held on the metallic sheet.
- (ii) Intensity of colour change noticed if any for copper sulphate solution perhaps you may record positive change with respect to each of the points for all the three solution of the broken, advanced by the following changes:

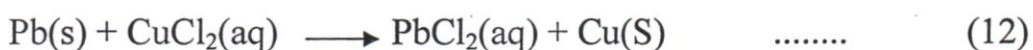
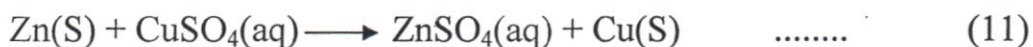
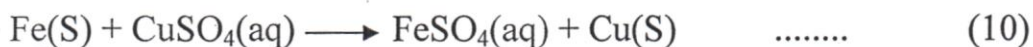

Now the pertinent question that arises is as to why the reactions (10), (11) and (12) are taking place. One way to interpret the occurrence of the reaction could be that more active metal enters in the combined form and displaces the less active metal from its solution. In precise we may say metals, Fe, Zn and Pb are more active than Cu and therefore cause the reaction. Reaction in which the more reactive metal displaces the less active metal from its solution is called displacement reaction. You may now ponder over on the following metal activity seriation also called as metal activity series:

Mg, Al, Zn, Fe, Pb, Cu, Ag

Metal activity decrease from Mg to Ag in a regular gradation manner. (Now can you guess why copper sulphate solution can be safely stored in a pot made from action)

Activity-2

Procure three test tubes and add 3 mL solution of BaCl₂, CuSO₄ and Al₂(SO₄)₃ to these, which after addition may be marked as test tube 1, 2 and 3 respectively. To the test tube (1) add 1 mL Na₂SO₄ solution, to test tube (2) add 1 mL Na₂CO₃ solution and test tube (3) add 1 mL of NaOH solution. What do you observe. You come across with formation of precipitate in each case as advanced by the following reaction



Such reactions which involve an exchange of ions between the reactants are called double decomposition reactions. Now you may appreciate the reaction.



Redox Reactions ... Electronic Concept in terms of gain/ loss of Electrons by the species

Let us recall a famous reaction, that we have so oftenly seen being demonstrated by our teacher, the burning of magnesium ribbon in air represented as:



Air

Wherein we encounter white dazzle light as magnesium burns in air, this reaction though is known as combination reaction but is equally well is said to be a reaction where magnesium in formation of its oxide adds oxygen to itself. This addition of oxygen to magnesium is conventionally called oxidation of magnesium. Let us represent this reaction in another frame of reference. Since $[\text{Mg}^{2+}\text{O}^{2-}]$ is another way of writing MgO . It conveys that in formation of $\text{Mg}^{2+}\text{O}^{2-}$, magnesium loses two electrons and oxygen gains two electrons. Further as already said as per classical concept reaction (18), is a redox reaction, we may safely conclude from here that oxidation of magnesium can be viewed from two different angles.

- (i) Addition of oxygen to metals leading to formation of metallic oxide is oxidation of metals and in additionality.
- (ii) Loss of electrons by magnesium leading to the formation of Mg^{2+} is also its oxidation. This change invariably can be said to be in a generalized form now as:

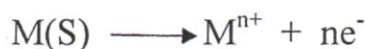

For sodium and potassium metals the n value is unity, for metals like Mg, Zn, Fe, the n value is 2 and evidently for Aln, value is 3. This suggests that the number of electrons that a metal under control able conditions can lose is the number of electrons present in its valence shell, we must not overlook one aspect that a species will lose electrons only if there is another one in the reaction under examination, which can gain electrons. To summarize we may say here Mg is oxidized to Mg^{2+} and O from O_2 is reduced here as O^{2-} , indicating that gain of electrons by the species is its reduction.

Exothermic and Endothermic Reactions/Charges

Let us again consider the reaction:



(Quick lime)

Which in our frame of reference was a combination reaction, from our experiences about whitewashing we have come across with the outcome that a large amount of heat is evolved in this reaction. You may now procure 10 mL of water in each of the two different test tubes and two one of the test tube now add 2 mL concentrated H_2SO_4 and to the other one add two mL of concentrated HNO_3 . You may observe that here also in dilution of the acids heat is produced. Such reactions/ changes which evolve heat as called exothermic changes. Burning of hydrocarbons which is of great practical utility is a celebrated another example of exothermic changes.

Endothermic Reactions / Changes

Once again we consider another combination reaction that we have already transacted namely, $\text{N}_2(\text{g}) + \text{O}_2(\text{g}) \longrightarrow 2\text{NO}(\text{g})$. It has already been pointed out that this reaction occurs during thundering only indicating that energy is required for the occurrence of the charges such reactions/ charges which for their occurrence need energy are said to be as endothermic, charges/reactions. Decomposition of alkaline earth metal carbonates is another classical example of endothermic change denoted by the reaction:



Where M stands for any of the alkaline earth metal namely Be, Mg, Ca, Sr and Ba.

[Do you think these alkaline earth metal carbonates will decompose at different temperatures? If so then why?]

Some more endothermic changes that we experience in daily life are:





[Which will be associated with more heat 1mL H₂O as liquid or 1mL of water as vapours]

Let us now again consider the change,



As it is a photosynthesis reaction persons of hotary usually state that in this change the entire source of O₂ is water, do you now appreciate why 12H₂O appears on reactants side. This question was purposely postponed, as at this stage you here now lot read about the balanced chemical reactions. You may also appreciate why the following reaction occur.



Force and Newton's Laws of Motion

Dr. Shivalika Sarkar

Assistant Professor, RIE Bhopal

Subject: Science

Key Concepts of force and Newton's three laws of motion

Learning concepts: To understand the concept of force, interaction between two objects, explain the motion of an object as resulting from the forces acting on the object and hence the Newton's three laws of motion.

Learning objectives:

1. To understand that force is not only associated with a body in motion
2. To understand that objects at rest are subjected to balanced forces
3. To understand that unbalanced forces will lead to objects slowing down, speeding up or changing direction
4. To understand the concept of NET force, sum of all forces acting on an object and its connection with Newton's first and second laws of motion
5. To find out the direction of force acting on an object
6. To understand that Force acting on any object in any situation is always the result of its interaction with another object force as acting on one object from (or due to) another object. That is concept of pair forces and their connection with Newton's third law of motion.
7. To understand that there does not exist any definition of force independent of Newton's laws of motion
8. To draw free body diagram and calculate the forces associated with it.

Excite

Teacher will ask students to give examples of some situations/statements where the term force is used.

For example

- police force,

- 'Dad forced me to do it',
- 'May the force be with you',
- 'Don't force it — it might break',

Ask student which of these uses matched most closely to the scientific meaning. The answer will be of course the last point

Exploring questions:

1. **What does the word Force makes you think about?"** Students will share within the group and then choose a few to share with the class.
- Having students arm wrestle to show balanced forces (when the same amount of force is applied by each person) and unbalanced forces (when one person wins). The students will learn the effects of unbalanced forces by sharing what they felt as they were winning or losing. Give a rope and ask two students to hold the opposite ends and start pulling in the opposite directions? Ask the students what will happen? Summarize when we have pulls in opposite direction there is no movement. Ask students what happens pulls are not equal? In which direction will the rope move? This will also be a good example to demonstrate the effect of balanced and unbalanced forces. unequal forces acting in opposite directions that results in movement in the direction of the larger force.

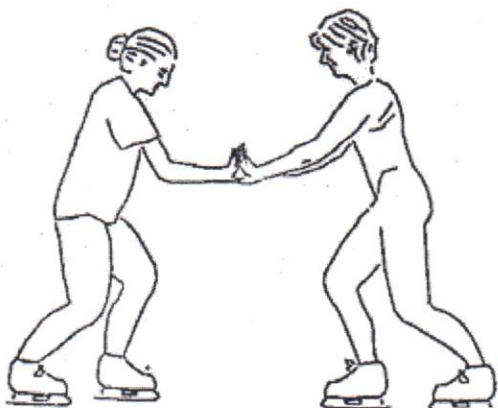
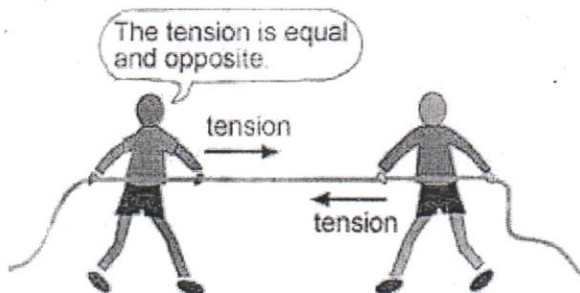

Ask students if they can think of other examples to demonstrate the effect of balanced and unbalanced forces.

2. Is force associated with moving objects only or with stationary objects also?

Place a book on the table. Ask the students to make a rough picture of this in their notebooks. Ask them whether any forces are involved or not?

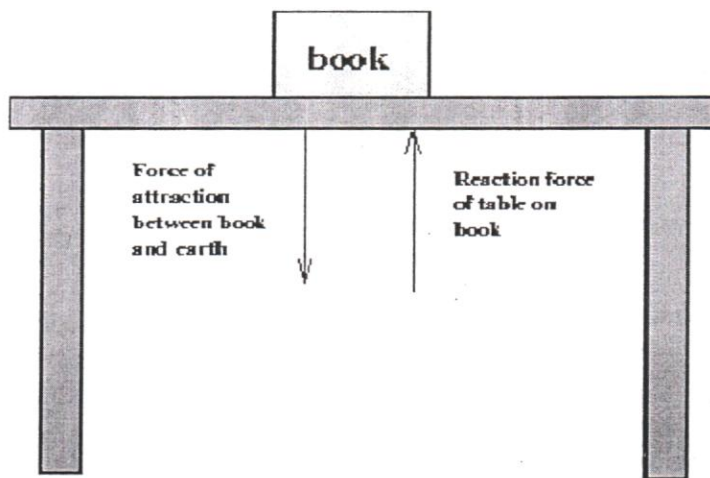

This activity will help students realize that forces are associated with stationary objects also only that the net forces are balanced so there is no motion.

3. What is net force?

To define net forces give one example of a stationary object and one of moving object. **Take any example of an object in motion or at rest and identify all the forces acting on the object and then state whether they all sum up to zero or not?**

Ask the students to label all the forces involved.

For stationary object the example of a person standing on a floor can be given. Ask the students what forces are acting on a person standing on the floor.

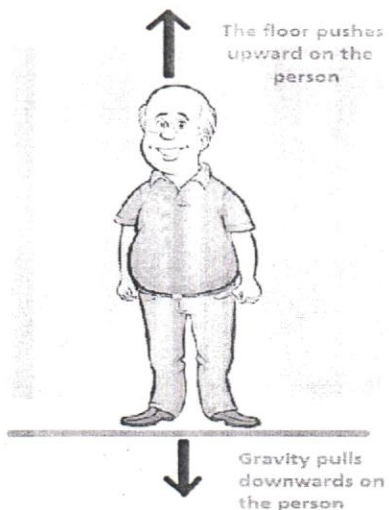

To calculate the net forces on a moving object consider a ball thrown vertically upwards. What kind of motion you expect? You find that the ball loses its speed as it climbs up until it stops climbing up and starts falling down. In this considered example, or you may actually throw a ball upwards in the classroom and ask your students following questions about the upward and downward journey of the ball.

1. Identify the forces acting on the ball also identify by whom each of the force is applied (neglecting air resistance).
2. What is the direction of the net force on the ball as it climbs up and when it comes down?
3. What is the direction of the net force acting on the body as it comes to momentary rest, before its starting of downward journey?
4. What about the magnitude of the force?
5. What is the cause of this force?

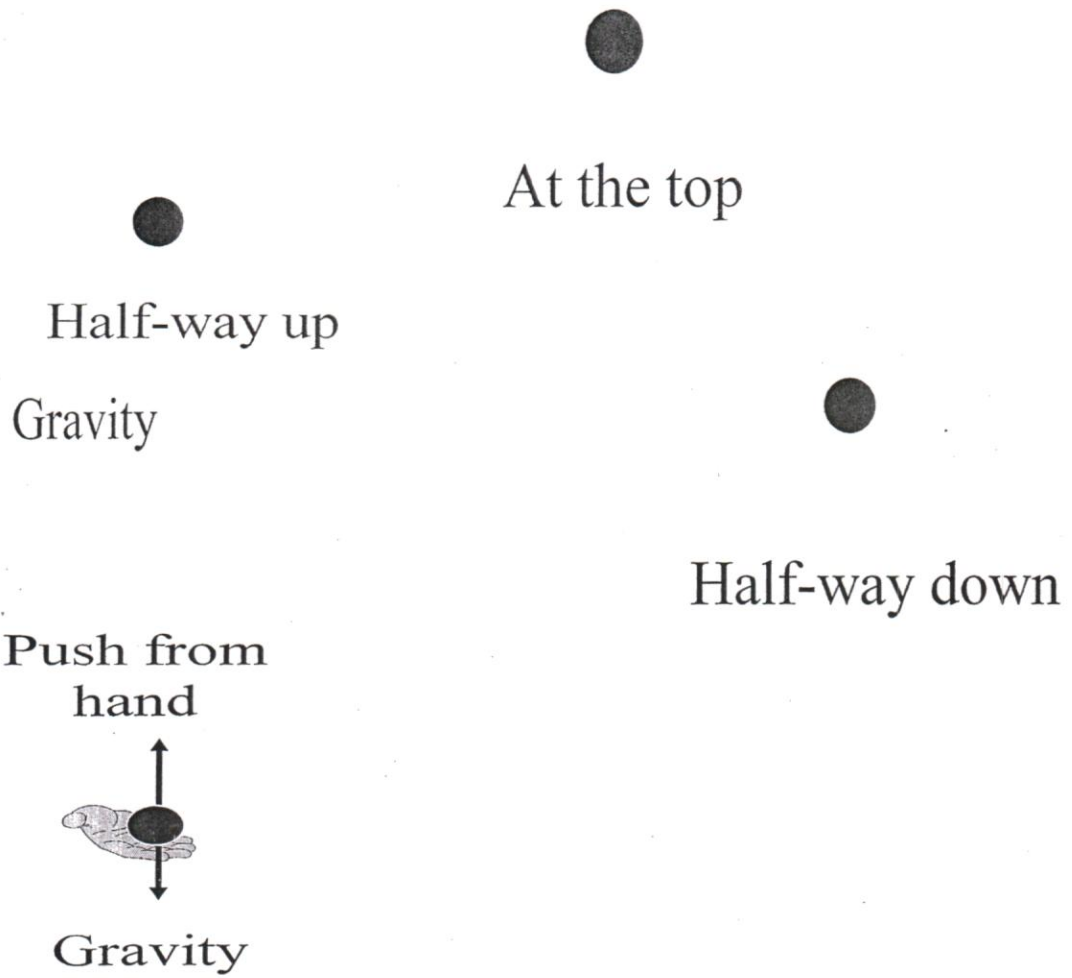

4. How much force is acting on a body moving with constant velocity?

A car travels at a constant 60 mph, along a flat road. What are the forces acting on it?

Is the forward force greater than, equal to or less than the combined backward forces?

5. Is the wind (blow football, wind on leaves) a force-at-a-distance?
6. If you release a stone from a height what are the forces acting and how you calculate the net force?

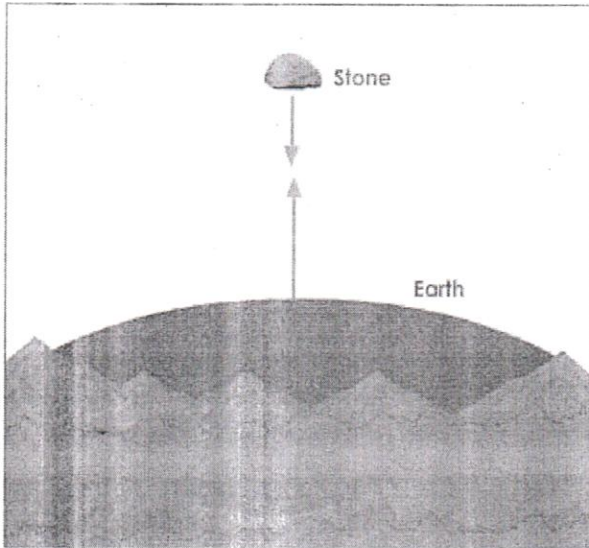

If you allow a stone to fall and if its acceleration is observed as 'a' then 'ma' gives us the net force acting on the stone. This net force is the combination of the force due to earth and the opposing force due to surrounding air.

7. Give ten examples of force acting on one object from (or due to) another object.

Students will give several examples in which action and reaction forces are involved. Recoil of gun, Propulsion of a boat in forward direction. These forces act on different objects and so they do not cancel each other.

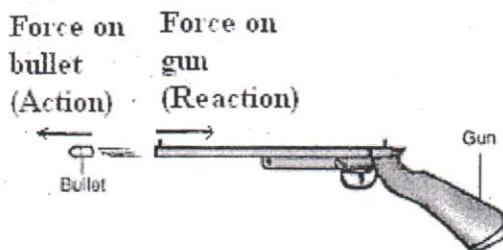

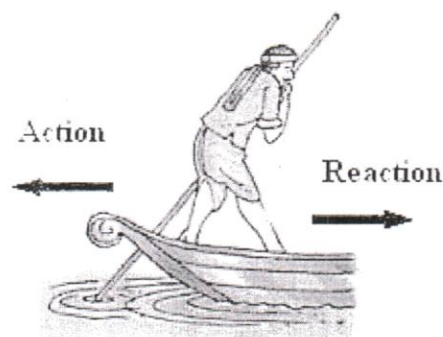
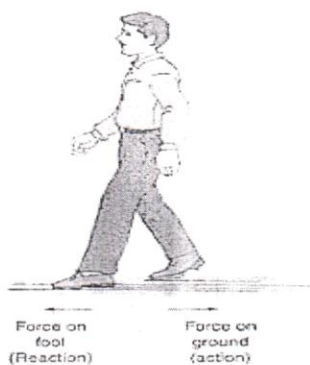

Possible misconceptions among students

Students are aware of the fact that force is push (makes something start or stop moving) or pull (makes something that's already moving go faster or slower). Also that force causes change in shape. Some of them might even be aware of the forces at a distance like the gravitational force, magnetic and electric forces. The alternative conceptions that can arise in a student's mind are listed below:

1. Force is associated with the body till it is in motion.
2. When a body is at rest the force acting on it is zero.
3. Force is always in the same direction as the velocity of the body.
4. If the velocity is changing then force is also changing.
5. The action-reaction forces act on the same body.
6. The product of mass and acceleration is force.
7. Only animate things like people and animals exert forces; passive ones like tables, floors do not exert forces.
8. Forces applied by, say a hand, still acts on an object after the object leaves the hand.

Restructuring of ideas/Explanation

Having understood the concept of balanced and unbalanced forces students can now write the newton's first law of motion in their own words. While discussing the examples mentioned above the teacher can explain to the students to consider a body on which no net force acts. If the body is at rest, it will remain at rest. If the body is moving with constant velocity, it will continue to do so. An important word here is NET. It means "total" or "sum of all" (forces). It

is not that no force at all can act on the body. It is just that all the forces must add to zero (cancel each other out).

Therefore Newton's First Law of Motion can be written as:

Every object persists (stays) in its state of rest or uniform motion in a straight line unless it is compelled (made) to change that state by forces impressed (acting) on it .

According to Newton's first law of motion things come to rest not because they naturally do but because forces act on them to bring them to rest. A common force is friction – which is the push or pull things give to each other when they rub together. Eliminate friction and things would keep moving in a straight line.

- Compare surfaces with more and less friction
Ice vs. carpet
- Newton's first law does hold true as long as you account for all the forces.

Discussing the Newton's second law of motion teacher can discuss the example of a stone thrown from a height. If you allow a stone to fall and if its acceleration is observed as 'a' then 'ma' gives us the net force acting on the stone. This net force is the combination of the force due to earth and the opposing force due to surrounding air.

So, newtons second law of motion which is commonly shortened to "F=ma".

Correctly, it is :

$$\Sigma \vec{F} = m\vec{a}, \quad \vec{a} = \frac{\Sigma \vec{F}}{m}$$

This is the reason that the stone and a piece of paper do not fall down with same acceleration. If you attach a small stone to a parachute made out of a polythene bag and allow it to fall, at first, the stone would tend to fall fast enough and increase its speed and we may conclude that there is some net force acting on the stone. But after some time you may notice that the stone is falling down almost with uniform speed with zero acceleration. From this observation you can conclude that net force acting on the stone is zero. The force due to earth remains same but the opposing force due to air because of the parachute increases with increasing speed. When these opposite forces cancel each other the velocity of the stone does not increase.

Discussing the examples mentioned above teacher can explain the Newton's third law of motion. Whenever two bodies interact with each other, the force exerted by the first body on the second is called action. The force exerted by the second body on the first body is called reaction. The action and reaction are equal and opposite.

Newton's Third Law of Motion states: 'To every action there is an equal and opposite reaction'.

It must be remembered that action and reaction always act on different objects. The Third Law of Motion indicates that when one object exerts a force on another object, the second object instantaneously exerts a force back on the first object. These two forces are always equal in magnitude, but opposite in direction. These forces act on different objects and so they do not cancel each other. Thus, Newton's Third Law of Motion describes the relationship between the forces of interaction between two objects.

Evaluation

1. Assuming air resistance can be ignored, which gets to the ground first, a bowling ball or a tennis ball if they are dropped from the same height at the same time? Explain.
2. Does a book at rest on the table have no forces acting on it? Explain.
3. A car is traveling at a constant 60 mph in a straight line. What is the net force acting on the car?
4. Draw the diagram showing a body of mass m in projectile motion under gravity. Show the magnitude and direction of the force acting on the body when it is a) ascending, b) at the top most position, and c) descending. Give reasons.
5. We take say 5 identical paperweights and put them on a fairly smooth horizontal table so that they touch each other and lie on a straight line. Now if we hit this line of paperweights head on with another identical paperweight moving horizontally in the same line, it is found that one paperweight at the end of the line moves out and the moving paperweight comes to rest. Explain this observation on the basis of the principle of conservation of momentum and in terms of the force acting on each paperweight.

गति

व्यक्त कठिनाईयां और पुस्तक की त्रुटियां

शिक्षकों ने कठिनाईयों के विशिष्ट बिन्दु न बताते हुए उन्हें सामान्यीकरण कर प्रस्तुत किया है। उदाहरणार्थ ग्राफ समझने में सूत्र समझने में परिकल्पना, धनात्मक, गुणात्मक चरण समीकरण वृत्तीय गति इत्यादि। इस कारण अध्याय को पूरी सजगता से पढ़ा गया और उस में त्रुटियां ढूंढी गयी और उन को उल्लिखित कर संभावित तथ्य जिसके कारण शिक्षकों को समझने में दिक्कत आ सकती है उन को लिखा गया है और इन पर चर्चा की गयी है। इस का विवरण पुस्तक में लिखी गयी सामग्री के परिप्रेक्ष्य में प्रथम पृष्ठ से लेकर अंतिम तक अध्याय में दिये गये शीर्षक को साथ सुझाव दिये जा रहे हैं ।

1. प्रस्तावना (4.1 के पहले जो कुछ लिखा गया उसे प्रस्तावना समझा गया है) प्रस्तावना अच्छी है किन्तु कक्षा में इसी तरह से न कहकर और अन्त में छात्रों से एक दो उदाहरण देने के लिए कहने के बजाए, छात्रों की गति का अर्थ मालूम है और उस ने अनेक गतिमान वस्तुएं देखी है। अतः उन्हें इस के उदाहरण देने के लिए कहा जा सकता है। ध्यान रहे कि कक्षा के प्रत्येक छात्रों को उदाहरण देने के लिए कहा जाना आवश्यक है। हम यहां जानबूझकर 40 उदाहरणों की एक सूची (Index) दे रहे हैं जैसे के छात्रों के भी उदाहरण हो सकते हैं। अगर छात्र सटीक नहीं है। तो उसे शिक्षक ने अलग से संज्ञान लेकर उन्हें उस पर आवश्यकतानुसार इसी छात्र से यह सम्पूर्ण कक्षा से चर्चा हो सकती है; उसी समय या बाद में भी हो सकती है।

1. सड़क पर चलता हुआ मनष्य
2. सड़क पर चलने वाला आटो, बैलगाड़ी

3. बैल गाड़ी का चक्का चलते हुए
4. फूल से फूल पर उड़ने वाली तितली
5. घूं घूं कर गति करने वाला मच्छर या कोई अन्य कीट
6. हेलिकॉप्टर / अगर प्रत्यक्ष न देखा हो तो (Video)
7. फिश पॉट में गति करती मछली
8. नदी में बहता हुआ पानी (कैसे पता चलता है कि पानी बह रहा है।)
9. पवन का बहना (कैसे पता चलता है कि हवा गति कर रही है)
10. पोखर में या तालाब में पानी का भंवर
11. फव्वारों में पानी की गति
12. पार्क में दौड़ते हुए व्यक्ति चलते या दौड़ते हुए
13. चलते हुए या दौड़ते हुए, हाथ पैरों की गति
14. संगीत ध्वनि निकलने संबंधी सितार के तारों की गति
15. स्कूल बेल की पृष्ठ की गति जब बेल बजती हो
16. उड़ते पंछी
17. घड़ी के लोलक की गति
18. पहाड़ी चढ़ने वाले की गति
19. घड़ी के सुईयों की गति
20. झूलने के समय झूले की गति

21. चांद की प्रतीत गति
22. सूरज की प्रतीत गति
23. सितारों की गति
24. पृथ्वी की गति
25. शरीर में रक्त की गति (अवलोकन या जानकारी)
26. पौधों में जल का मूल से उपर तक बढ़ाव
27. दवाई के गोली की गति जब उसे निगला जाता है।
28. खेल के मैदान पर एथलीट की गति
29. बंदूक की गोली की गति
30. गेंदबाल से छोड़ी हुई गेंद की गति
31. गेंद को खेलते समय बैट की गति
32. कचरा निकालते समय झाडू की गति
33. समुद्र में उठने वाली बड़े तरंगों की गति
34. तबले के पृष्ठ की गति जब उससे ध्वनि निकलती है।
35. दरवाजे का बंद होना
36. खिड़की का खोलना
37. क्रेन की गति
38. लिखते समय पेन या पेंसिल की गति

39. साईकिल चलाते हुए पैरों की गति

40. तैरते वक्त हाथों की गति

कक्षा में इस प्रकार उदाहरण छात्रों द्वारा दिये जाने की अपेक्षा है। प्रत्येक छात्र को अलग उदाहरण देने को प्रवृत्त करना होगा, कुछ उदाहरणों पर चर्चा सवाल, जवाब होना भी अपेक्षित है।

4.1 गति का वर्णन

दिये गये उदाहरणों से सरल रेखा गति के उदाहरणों को छांटा जा सकता है और इस में पिण्ड के गति का वर्णन करने के लिए पुस्तक का उदाहरण समझाया जा सकता है। पुस्तक में दूरी और विस्थापन के अंतर को केवल सरल रेखीय गति के संदर्भ में समझा गया है किंतु किसी भी गति का उदाहरण देकर भी समझाया जा सकता है। विस्थापन की एक निश्चित दिशा होती है यह इस से स्पष्ट हो जायेगा।

4.1.1 चाल एवं वेग

चाल तय की गयी दूरी का समय—दर है। (Time-rate of change of distance) इस का मान प्रति इकाई समय में चली गयी दूरी के बराबर हो सकता है। किंतु उसे वैसे परिभाषित नहीं किया जाना चाहिए। प्रायोगिक रिन्या औसत चाल ही ज्ञात की जाती है जिसके लिए औसत चाल = कुल तय की गई दूरी सूत्र है।

कुल समयांतराल

तत्कालिक चाल एक अवधारणा है जिसे गणितीय रूप से ही समझा जा सकता है। क्योंकि हम पुस्तक में सरल रेखीय गति को समझा रहे हैं यह स्पष्ट करना चाहिए कि बस एक सीधी सड़क पर चल रही है और अगर ऐसा है तो वेग की दिशा एक सी ही होगी और नहीं तो वेग की दिशा बदलते रह सकती है भले ही उसका मान जैसा कि बस के लिए कहा गया है

कि वह सामान चाल से जा रही है। दोनों उदाहरणों के ग्राफ बनाये जाने थे। इस क्रिया के लिए एक वस्तु के तीन (s-t) द्वारा दिया है और (s-t) बनाकर देखा जा सकता है। उस के संदर्भ में निम्न प्रश्नों का उत्तर दें।

1. क्या गति एक समान है किस डाटा के लिए ?
2. अलग-अलग L2-L1 के लिए औसत चाल की गणना करें।
3. क्या औसत चाल स्थिर है या बदलनी है कैसे समझाए।

4.1.2 वेग (Velocity)

यहां वेग की चर्चा केवल सरल रेखीय गति के लिए की गयी है और उदाहरण भी केवल अति विशिष्ट दिये गये हैं जिसमें एक में चाल कुछ आना है और वेग शून्य ही आना है। वेग की निश्चित दिशा होती है यह इस से स्पष्ट नहीं होता। इस बात को समझाने के लिए एक तल में गति का उदाहरण देना आवश्यक है इस का उदाहरण एक चीटी की गति का दिया गया है जो एक नल पर चलती है। चीटी का पथ दिखाया गया है यह पथ का ग्राफ नहीं है। ग्राफ के लिए चीटी का x और y का अलग-अलग समय के साथ ग्राफ दिखाना होगा।

इस में चीटी की दो समय के बीच औसत चाल और औसत वेग की मात्रा और दिशा समझनी होगी। वेग की दिशा एक (arrow) जगह \longrightarrow से दिखाई जाती है जिसे एक प्रारम्भिक बिंदु वस्तु की पूर्व स्थिति होती है और शिरोबिन्दु उस की समयांतर के बाद की स्थिति होती है।

4.2.1 अलग-अलग चाल वाली एक समान गति

और

4.2.2 रूकने का ग्राफ

दोनों का प्रस्तुतीकरण योग्य है कुछ शंकाएं हैं तो उसे प्रशिक्षण शाला में समझायी जायेगी।

4.2.3 असमान गति का एक ग्राफ

इस का भी प्रस्तुतीकरण योग्य है। केवल एक प्रश्न पूछा जाय कि यह ग्राफ किस गति को दर्शाता है वह कैसी सरल रेखीय गति है कि नहीं ? छात्र और कभी हम शिक्षक भी वस्तु के पथ के चित्र और उस के s-t ग्राफ में अंतर नहीं समझते। बाकी प्रस्तुती सही है।

4.2.4 त्वरण

प्रस्तुतीकरण सही है केवल पृष्ठ 58 पर लिखे गये वाक्य में "इस तरह त्वरण समय वेग ज्ञात कर सकते हैं" ये वेग की जगह वेगांतर भी लिखा सकना है।

4.3 गति समीकरण

प्रस्तुतीकरण योग्य है ग्राफ के साथ तर्क द्वारा भी समझने की कोशिश करनी चाहिए कि वेग x समय ग्राफ के बीच का क्षेत्रफल दो समय के बीच चली गयी दूरी का मान होता है। यहां यह बात अटपटी लग सकती है कि 'क्षेत्रफल' दूरी कैसे हो गया तो उस का कारण है कि Y अक्ष पर v x (मी/सं) ओर X अक्ष पर t (समय) है इसलिए u (मी./सं) x समय (से) का मान मी में दूरी आता है।

4.4 वृत्तीय गति

प्रस्तुतीकरण अति संक्षिप्त है। थोड़ी विस्तृत चर्चा भले ही गणितीय और रेखीय हो, होनी चाहिए। यहां वस्तु QP का

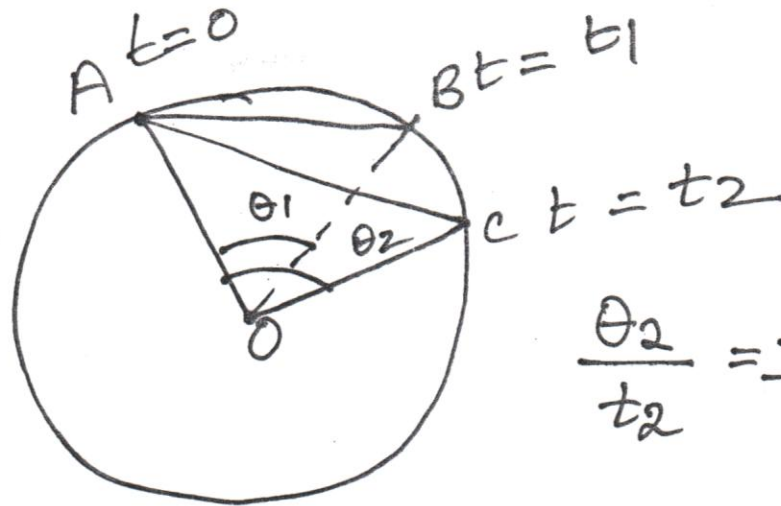

$$\frac{\theta_2}{t_2} = \frac{\theta_1}{t_1} = \text{const } \omega$$

1. चाल की मात्रा कितनी है। दूरी = $P, R = Q_2 R = WR$

$$\frac{\theta_1 R}{t_1} = \frac{\theta_2 R}{t_2} = \omega R$$

$$\text{चाल} = \frac{\text{दूरी}}{\text{समयांतर}} = \frac{Q_1 R}{t_1} = \frac{Q_2 R}{t_2} = \omega R$$

समयांतर चाल नियम है।

$$\text{औसत वेग} = \frac{AB}{t_1} = \frac{AC}{t_2} = 2R \cos(\theta_1/2)$$

$$\text{तात्कालिक वेग} = R \frac{d\theta}{dt} = \omega R$$

तात्कालिक वेग का मान wR और दिशा स्पर्श रेखा होगी। उसी प्रकार से सिद्ध किया जा सकता है कि त्वरण का मान w^2R और दिशा O की तरह हमेशा होगी। अतः एक समान वृत्तीय गति में त्वरण केन्द्राभिमुख होता है और उस की मात्रा u^2/R w^2R होता है।

हमने सीखा –

इस में निम्न बदलाव वांछनीय है।

1. वस्तु की दो स्थितियों (प्रारम्भिक और अंतिम) को जोड़ने वाला किरण विस्थापन कहलाता है उस किरण की लम्बाई विस्थापन का मान और किरण की दिशा विस्थापन की दिशा कहलाती है। यह ही बात सरल रेखीय गति के लिए भी सही है किंतु इस उसे + और – कहते हैं।

अभ्यास प्रश्न –

(iv) (अ) विकल्प के जगह पेंडुलम की गति लिखना अधिक ठीक होगा।

4. प्रश्न गलत है सूर्य के चारों ओर कोई वस्तु नियम वेग (Velocity) से कैसे जा सकती है?

5. प्रश्न सही नहीं है विस्थापन सदिश को आदिश की तरह ग्राफ नहीं बन सकता हां विस्थापन की मात्रा का बन सकता है। या तो विस्थापन की जगह दूरी लिखा जाये।

HEREDITY

Dr. Pramod Patil
Professor,
Institute for Excellence in Higher Education,
Bhopal - 462016
Email : drpatil.pramod@gmail.com

Introduction :-

Heredity is the passing on of traits from parents to their offspring, either through asexual reproduction or sexual reproduction, the offspring cells or organisms acquire the genetic characters from parents to offspring : it is dependent upon the genes during meiosis and fertilization and results in the genesis of a non individual similar to others of its kind exhibiting certain variations resulting from the particular mix of genes and their integrations with the environment.

- Genetics deals with the Study OF heredity and variation.
- The transmission of characters/traits from one generation to the next generation is called Heredity.
- The differences in the characters/traits between the parent and offspring is called Variation.

Types of Variations

- **Variation are of two types:**
 - (i) Somatic Variation
 - (ii) Gametic Variation
- **Somatic Variation**
 - It takes place in the body cell.
 - It is neither inherited nor transmitted.
 - It is also known as acquired traits.
 - Examples : Cutting of tails in dogs, boring of pinna etc.
- **Gametic Variation**
 - Takes place in the gametes/Reproductive cells.
 - Inherited as well as transmitted.
 - Also known as inherited traits.
 - Example : human height, skin colour.
- **Accumulation of Variation during Reproduction**

- Variation occurs during reproduction whether organisms sexually or asexually.
- **Variations in Asexual Reproduction**
 - Variations are fewer.
 - Occurs due to small inaccuracies in DNA copying. (Mutation)
- **Variations in Sexual Reproduction**
 - Variations are large
 - Occurs due to crossing over, separation of chromosomes, (Mutation)
- **Importance of Variation**
 - Depending upon the nature of variations different individuals would have different kinds of advantage.
Example, Bacteria that can withstand heat will survive better in a heat wave.
 - Main advantage of variation to species that it increases the chances of its survival in changing environment.
 - Free ear lobes and attached ear lobes are two variants found in human populations.
- **Mendel and His Work on Inheritance**
 - Gregor Johann Mendel (1822 & 1884) started his experiments on plant breeding and hybridization. He proposed the laws of inheritance in living organisms.
 - Mendel was known as Father of Genetics.
 - Plant selected by Mendel: *Pisum Sativum* (garden pea). He used a number of contrasting characters for garden pea.
- **Seven pairs of contrasting character in Garden Pea.**

Character Trait	Dominant Trait	Recessive Trait
Flower colour	Violet	White
Flower position	Axial	Terminal
Flower colour	Yellow	Green
Seed Shape	Round	Wrinkled
Pod Shape	Inflated	Constricted
Pod Colour	Green	Yellow
Height of Plant	Tall	Dwarf/Short

- **Mendel's Experimental Material**
- He chose Garden Pea (*Pisum Sativum*) as his experiment material because of:
 - Availability of detectable contrasting traits of several characters.
 - Short life span of the plant.
 - Normally allows self-fertilisation but cross-fertilisation can also be carried out.
 - Large no. of seeds produced.
- **Mendel's Experiments :-** Mendel conducted a series of experiments in which he crossed the pollinated to study one character (at a time)
- **Monohybrid Cross :-**
 - Cross between two pea plants with pair of contrasting character is called a monohybrid cross.

Example : Cross between a tall and dwarf plant (Short.)

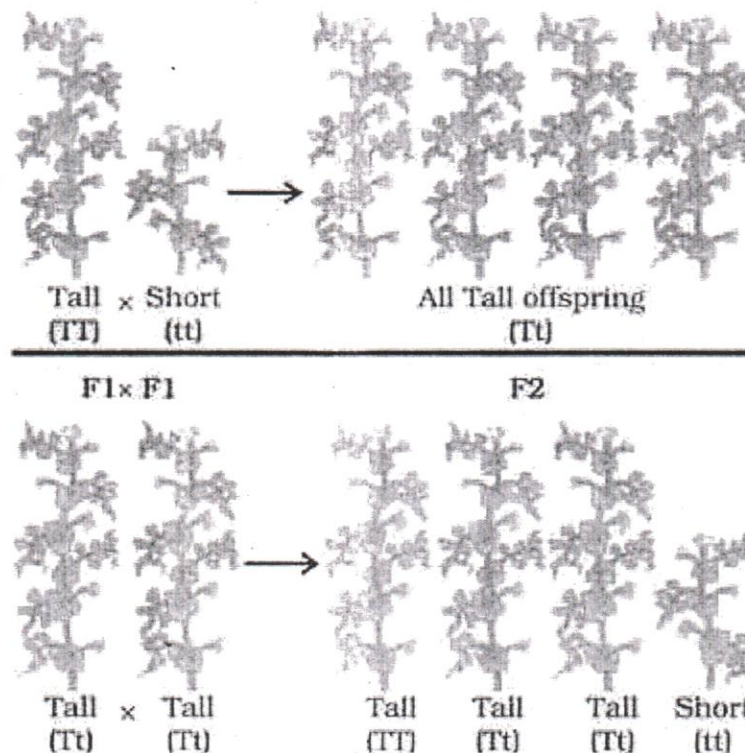

- First-generation of F1 progeny are no 'medium-height' plants. All plants were tall.
- Second-generation of F2 are progeny (descendant) of the F1 tall plants are not all tall.
- Both the tallness and shortness traits were inherited in the F1 plants, but only the tallness trait was expressed. Thus, two copies of the trait are inherited in each sexually reproducing organism.
- These two may be identical or may be different depending on the percentage.

- **Pure or homozygous condition**

- (TT, tt) : Both are dominant traits, Both are recessive alleles.

- Phenotypic ratio - 3 : 1 (Three tall and one short)
- Genotypic ratio - 1 : 2 : 1 (TT-one, Tt-two, tt-one)

Phenotype means Physical appearance either they are Tall or Short. Genotype means Genetic make up that are TT, Tt or tt.

- **Observations of Monohybrid Cross**

- (i) All F1 progeny were tall, no medium height plant. (Half way characteristic)
- (ii) F2 progeny 1/4 were short, 5/4 were tall.
- (iii) Phenotypic ration F2-3 : 1 (3 tall : 1 short)

- **Conclusions**

- TT and Tt both are tall plants while it is a short plant.
- A single copy of T is enough to make the plant tall, while both copies have to be 't' for the plant to be short.
- Characters/traits like 'T' are called dominant trait (because it express itself) and 't' are recessive trait (because it remains suppressed).

- **Dihybrid Cross**

A cross between two plants having two pairs of contrasting character is called dihybrid cross.

- A single copy of T is enough to make the plant tall, while both copies have to be 't' for the plant to be short.

- Parent - Round green x Wrinkled yellow

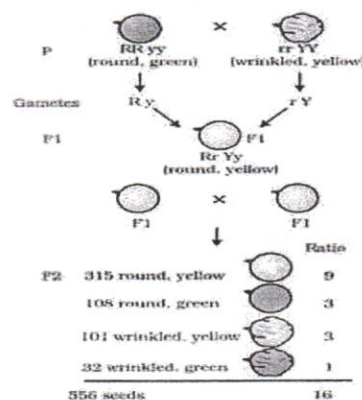

	RY	Ry	rY	ry
RY	RRYY	RRYy	RrYy	RrYy
Ry	RRYy	RRyy	RrYy	Rryy
rY	RrYY	RrYy	rrYY	rrYy
ry	RrYy	Rryy	rrYy	rryy

Phenotypic Ratio

Round, yellow : 9
 Round, green : 3
 Wrinkled, yellow : 3
 Wrinkled, green : 1

Observations

- (i) When RRyy was crossed with rrYY in F1 generation all were Rr Yy and yellow seeds.
- (ii) Self pollination of F1 plants gave parental phenotype and two mixtures (recombinants round yellow and wrinkled green) seeds plants in the ratio of 9 : 3 : 3 : 1.

• Conclusions

- Round and yellow seeds are Dominant characters.
- Occurrence of new phenotype combinations show that genes for round and yellow seeds are inherited independently or each other.

• How do these traits get expressed

- Cellular DNA is the information source for making proteins in the cell.
- A section of DNA that provides information for one protein is called the gene for that protein.
- Plant height can thus depend on the amount of a particular plant hormone. The amount of the plant hormone made will depend on the efficiency of the process for making it.

- Cellular DNA (Information source) - For synthesis of Proteins (Enzyme)- Works efficiently- More Hormone - produced Tallness of plant.

Therefore, genes control characteristics/traits.

• Sex Determination

Determination of sex of an offspring is known as Sex Determination.

- **Factors responsible for Sex Determination**

Environment and Genetic factors are responsible for sex determination.

- **Environmental**

In some animals, the temperature at which the fertilized eggs are kept decides the gender, Example : Turtle.

- **Genetic**

In some animal like humans gender or individual is determined by a pair of chromosomes called sex

Chromosome.

XX-Female

XY-Make

- **Sex Chromosomes**

In human beings, there are 23 pairs of chromosome.

Out of these 22 chromosomes pairs are called auto some and the last pair of chromosome that help in deciding gender of that individual is called sex chromosome.

XX-Female

XX Male

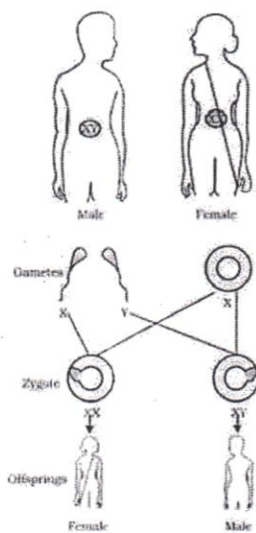

This shows that half the children will be boys and half will be girls. All children will inherit an X chromosome from their mother regardless whether they are boys or girls.

Thus, sex of children will be determined by what they inherit from their father, and not from their mother.

ELECTRIC CURRENT AND CIRCUIT

Prof M. Bapat

Email: mnbapat@gmail.com

(1) About circuit connection

- A. **Correction-** Page 77. There should be no joint to increase the length of the wire. We notice 3 connecting wires in each diagram.
- B. **Suggestions-** the figures have socket for the cell. It is one of the basic requirements of current to pass, that the joints should be tightly fitted.
- C. **Experimentation** - under what conditions the bulb would not glow. Let the pupil find out from among the following:

Use of old cell, use of fused bulb, loose connecting wires and any other.

- D. **How to make connection** – in addition to ensure that the connections are secure/tight, we need to remember that circuit is not discontinuous at any point. So we will remember following-

1. Connecting wires are not broken at any stage.
2. Battery is charged.
3. If any instrument is to be connected (which may include meters: Ammeter/Voltmeter, motor, electrical appliance/electric gadget, capacitors etc.), that has terminals marked with + and - .We need to remember that those are not sources of energy.
4. (a) The rule is current passes through + signed terminal of the battery till negative terminal of the battery. There can be no other power source. Then why the symbols appear in the devices? The reason is we are dealing with DC. when devices are marked with + and - , we need to connect terminals + to + and _ to - .

(b) Thus the rules say all positive terminals of the external devices, should be directly or **indirectly connected** to positive terminal of the battery following diagrams will elucidate it. It has three circuits (figures) in first we will explain why? In second part clue will be given as how to connect and in the third part you have to try out.

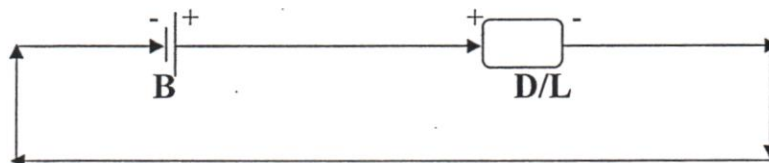

You may notice this is simplest circuit possible: just a battery B, two connecting wires and one appliance/device/load.

Next circuit is made up of addition of a galvanometer by breaking one of the wires to get two connecting terminals (wires) with indication of the direction of flow of current. Finally, connect them with galvanometer.

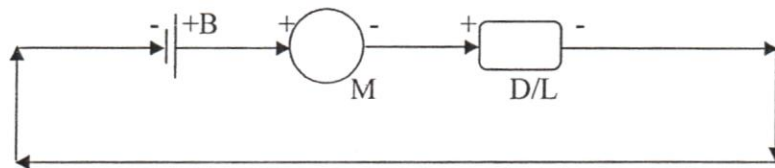

In the above diagram we have used 3 pieces of wire and a measuring device M. Device D or the Load L, may or may not have positive and negative signs. But if they have we need to remember rule number 4(b). If one says the load is connected to negative terminal of the meter. It is true. But see if it is indirectly connected? Yes it is. We need to remember positive terminal of a battery is truth, positive terminals of devices take up current through it. It is not source of energy. However, we need to be a little careful with capacitor, as it stores energy and we can tap it. So it is also a kind of source of energy.

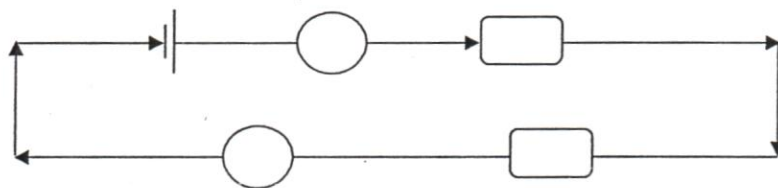

In the above figure remember arrowed lines are not so many wires, they just show the direction of flow of current, total number of wires is 5 only. Meters are two and loads are also two. Out of two terminal only one has + or - is written. Now put signs of plus and minus. Suggest how connections are to be done.

Note ammeter is connected in the circuit as if you are cutting the connection wire and the new open ends of wires are to connect them to terminals in right way. It suggests as if full current is passing through the Ammeter.

Some questions

Switch is connected in series or parallel in a circuit?

What is the use of fuse in a circuit?

How a device is represented in a circuit diagram? Hint: by a resistance.

An electric bulb is a load. True or false?

List down at least 10 devices and see if it has any active device.

Voltmeter – it has nothing to do with the circuit and hence need not be connected. If voltage is to be measured connect two wires to its terminals and connect those two terminals across the load

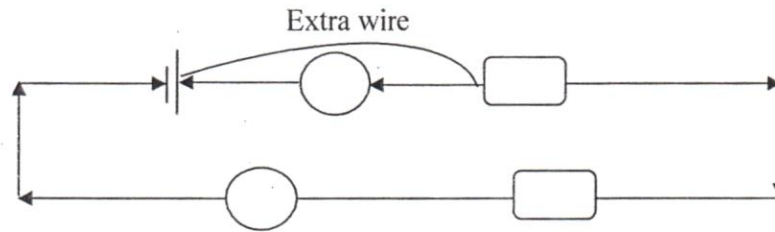

Suggest what is wrong with the circuit? Can the meter shown with extra wire be a voltmeter?

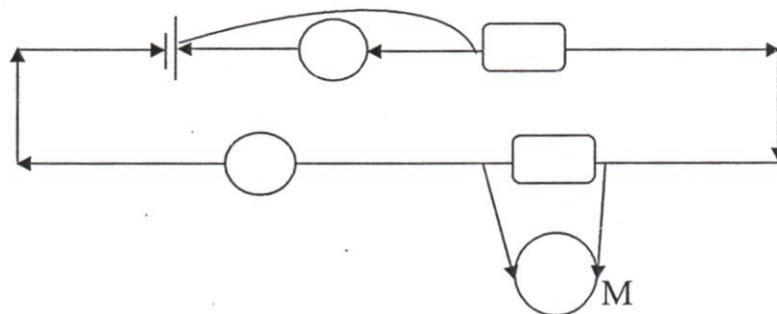

Can M be a voltmeter? Deliberate and put proper sign on the meter.

(2) About identifying the electrical components

Electrical components are many and varied. The best way is to teach the notations along with its actual form. A little effort has been made on page 79 but it is better to take photograph of those devices and paste them along with the symbol. Generally lower class labs use a battery of about 2 V or an eliminator.

Those components may be shown-

Eliminator, 2 V battery, connecting coiled copper wires, connectors with male terminals, flexible wires and difference with DC connecting wires, enamelled copper wires, and plastic coated wires. Some information regarding thickness/gauge of the wires can be exhibited/explained. Switches of different kinds such as- plug pin, one & two way keys, domestic switches and their construction. Carbon resistance, nichrom and mangnin wires, fuse wire and its properties. We may inculcate the idea in them that connecting wires are low resistance wires. Examples of silver, copper, aluminium and iron wires may be given. Rheostat is one of the important components in electrical and electronic circuitry. Its working can be shown as variable resistance devices. It may be shown and told that the commercial POT and fan regulators are special kind of rheostats.

Voltmeter, ammeter and galvanometer must be shown at one time and suggested that galvanometer can be converted in to VOLTMETER and AMMETER by connecting shunts. It is also useful to inform that generally galvanometer allows us to measure current in the range of a few tens of micro-ampere. If more than this current is passed through it, it may get damaged. Thus it can be informed that all kinds of meter (including ammeter and voltmeter) are made keeping in mind that they are essentially galvanometers but current through is limited as per prescription.

Chemical Bonding

Dr. Rashmi Sharma, RIE, Bhopal

Difficulty expressed:

- 1) Why ionic compounds are soluble in water?
- 2) Is only octet structure Imports stability to the species?
- 3) Are lone pairs around the atoms affects the covalency of the species?
- 4) Are elements always exhibit fixed valency?
- 5) Are atoms of a particular element always form one type of bonds only?

Major concepts:

- 1) Ionic Bond
- 2) Valency
- 3) Covalent Bond
- 4) Ionic and covalent compounds & their properties

Pedagogical suggestions:

- 1) Demonstrations using models & use of ICT
- 2) Group discussions
- 3) Accepting only written responses
- 4) Problem solving method

Ionic bond:

The elements those possess less than eight electrons in their outermost shell try to complete their octet by reacting with the atoms of same element or with the other. The bond which is formed by the complete donation or acceptance of the electrons by one atom to the other is regarded as the ionic bond. As a matter of fact, we know that each atom tries to retain 8 electrons in their outermost shell. This tendency of atoms to complete octet by donating or accepting the electrons is the basis of ionic bonding. Ionic bond can be best understood by the example of NaCl. We know that the Atomic number of Na is 11 & that of Cl is 17. Electronic configuration of these atoms can be written as-

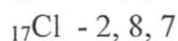
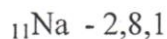

Now we need to look into the number of electrons in the outermost shell of each of the atom. We have to explore the possibility that what way it will be easy to complete the octet for both of the atoms. For example, Na can lose one electron or gain seven electrons. In the same manner Cl can either gain one electron or lose seven electrons. Here, two passing references we need to bring into discussion are:

- i) the atomic number means that atom possesses Equal no. of protons and electrons in the nucleus.
- ii) the atoms are neutral in their nature.
- iii) that atoms acquire negative charge by accepting electrons and positive charge by losing electrons from their outermost shell.

Now we again consider the case of Na & Cl. It is easier for Na to lose one electron because if seven electrons are accepted, the number of protons in the nucleus (11) will not be able to bind the 18 electrons in the shells. Therefore Na loses one electron and Cl gains one electron in order to complete the octet. In this process Na converts to Na^+ ion and Cl converts to Cl^- ion. These Na^+ ion and Cl^- ions attract each other (being oppositely charged) and develop electrostatic forces and form NaCl.

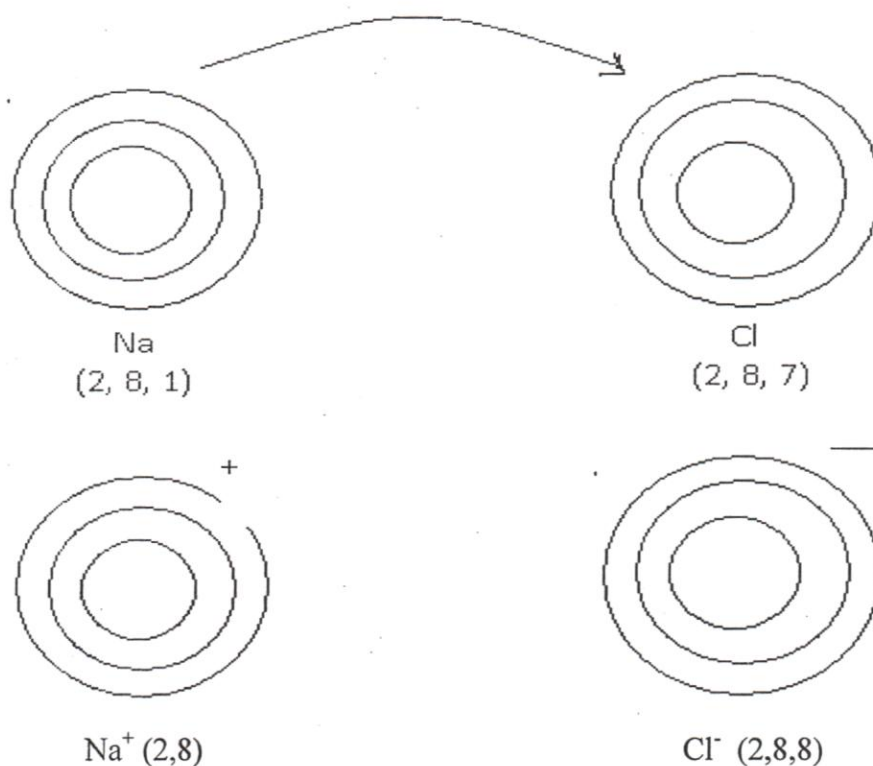

Likewise the formation of MgCl_2 , CaO , AlCl_3 and Na_2O also can be explained.

Suggested points:

While discussion in the class the following points need to be given emphasis-

1. Why any species attain charge during the formation of ionic compounds.
2. Compounds those conduct the electricity in their molten stage only are designated as ionic compounds.

- Ionic compounds are not only soluble in water but in the solvents of high dielectric constant also.
- Ionic compounds possess high melting and boiling points. This point can be strengthened by providing some data (Values of M.P. & B.P. of ionic compounds) before them

Name of the compounds	B.P.	M.P.
NaF		1253
KCl		1049
KF		1153
NaCl		1077
NaBr		1015

- Ionic compounds are water soluble. One should always remember that when the solvent can interact effectively with solute and if it can weaken the intermolecular bonds between solute species and can form new bonds with it, can dissolve the solute. In ionic compound species involved carry positive & negative charges with them. Likewise water also possesses positive & negative charge along its species. Therefore water can form new bonds with the ionic solute species and can dissolve the ionic compounds in general.

Additional Problems:

Q. 1. Arrange H, Cl & K in order of increasing affinity for electrons

Ans. These elements can form binary compounds like HCl, KCl & HF. In binary compounds elements which have tendency to lose electrons are written first as in NaCl. Here the order of increasing affinity for electrons will be –



This fact is evident from their electronic configuration also as in case of K it is 2,8,5 whereas for Cl it is 2,8,7 for H it is 1

Q.2. Point out similarities and differences amongst LiH, NaF and KCl

Ans. All three are ionic compounds. Therefore all can conduct electricity in their molten state. In each of the compounds cation is isoelectric with the anion.

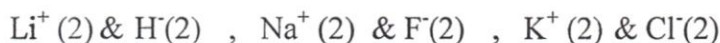

Q.3. KCl and CCl₄ both are compounds of chlorine but possess different states. Why? Suggest one activity to differentiate one from other.

Ans. KCl is an ionic compound. Like other ionic compounds each ion faces strong electrostatic attraction from many centers therefore it is solid, Whereas in CCl_4 , bonds between C & Cl are covalent (directional). In this compound Cl only at one centre faces attraction and it is liquid because of limited binding capacity.

The following activity can differentiate one from other:

KCl is water soluble and posses electricity whereas CCl_4 is not soluble in water and does not conduct electricity.

Exemplar Problem:

Q. What is the difference of the bonding patterns of the ionic compounds namely KCl & KOH?

Covalency:

Covalency indicates the loss or gain of the electrons by the element in order to attain the stability i.e. completion of the octet in general. For example metals always lose the electrons in order to gain the stability whereas non-metals in general gain the electrons for the same purpose. $_{19}\text{K}$ and $_{17}\text{Cl}$ exhibit the valency as one electron is lost or gain in order to complete the octet and attain the stability.

Covalent Bond:

Bond which is formed by sharing of electrons between two species is known as covalent bond. Number of electrons shared by a particular element is not always fixed. For example carbon forms single bond, double bond & triple bond also.

In C_2H_4 ($\text{H}_2\text{C} = \text{CH}_2$) carbon satisfies its two valencies by sharing with carbon and rest two other atoms

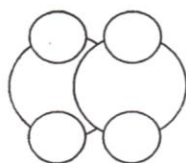
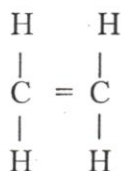

Covalent Bond in C_2H_4

Electronic configuration plays an important role in order to decide the bonding type between two atoms. For this purpose the electronic configuration should be written first and then decision should be taken about the bonding type.

Covalency in carbon:

Electronic configuration of carbon (${}_6\text{C}$) can be written as 2,4. As it is evident that C has 4 electrons present in the valence shell. To attain stable configuration like inert gas carbon either has to lose 4 electrons or gain 4 electrons. This way it is difficult for carbon to attain stability, therefore carbon prefers to share its valence electrons with another atom e.g. H, Cl, Br, N, C etc. Its covalency can be depicted as follows:-

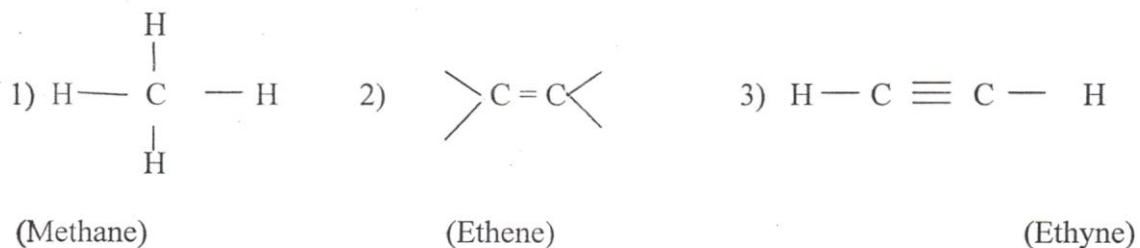

Element X with atomic number 6 and another element Y with atomic number 8 forms compounds of type XY_2 and X_3Y_2 . Draw the bonding mode between X and Y for these two compounds.

Ans. Element ${}_6\text{X}$ – configuration 2,4

Element ${}_8\text{Y}$ – configuration 2,6

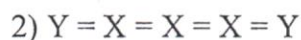
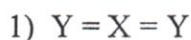

Exemplar problem:

Q. How lone pairs around the atoms affect the covalency of the species?

हाइड्रोकार्बन

डॉ. चित्रा सिंह
सह-प्राध्यापक
क्षेत्रीय शिक्षा संस्थान, भोपाल

वे कार्बनिक यौगिक, जो केवल कार्बन हाइड्रोजन से मिलकर बने हैं, हाइड्रोकार्बन कहलाते हैं। जिन हाइड्रोकार्बन में परमाणुओं की विवृत श्रृंखला (Open chain) होती है, वे ऐलिफेटिक हाइड्रोकार्बन कहलाते हैं। ये दो प्रकार के होते हैं (i) संतृप्त एवं (ii) असंतृप्त हाइड्रोकार्बन।

संतृप्त हाइड्रोकार्बन -

इसमें प्रत्येक परमाणु आपस में एकल सहसंयोजक बन्ध (C-C और C-H) द्वारा जुड़ा रहता है। इनको पैराफीन भी कहते हैं। ग्रीक भाषा के अनुसार पैराफीन का अर्थ है, कम क्रियाशीलता अर्थात् ये यौगिक कम क्रियाशील होते हैं। (पैरम (Parum) = थोड़ा), एफिनिस (affinis) = क्रियाशीलता)। इन पर अनेक अभिकर्मकों का, जैसे तीव्र अम्ल और क्षारों का, कोई प्रभाव नहीं होता है। आई.यू.पी.ए.सी. पद्धति के अनुसार इन्हें ऐल्केन (Alkane) कहते हैं। इनमें कार्बन परमाणु sp^3 संकरित होता है। C-C एवं C-H बंधन क्रमशः 1.54 \AA एवं 1.14 \AA होती है। ऐल्केनों में C-C उर्जा 80 किलो कैलरी प्रति मोल होती है। sp^3 संकरण होने के कारण इनकी आकृति चतुष्फलीय होती है। दो प्रारंभिक ऐल्केन, मेथेन, के अणु कक्षक चित्र निम्नानुसार होते हैं -

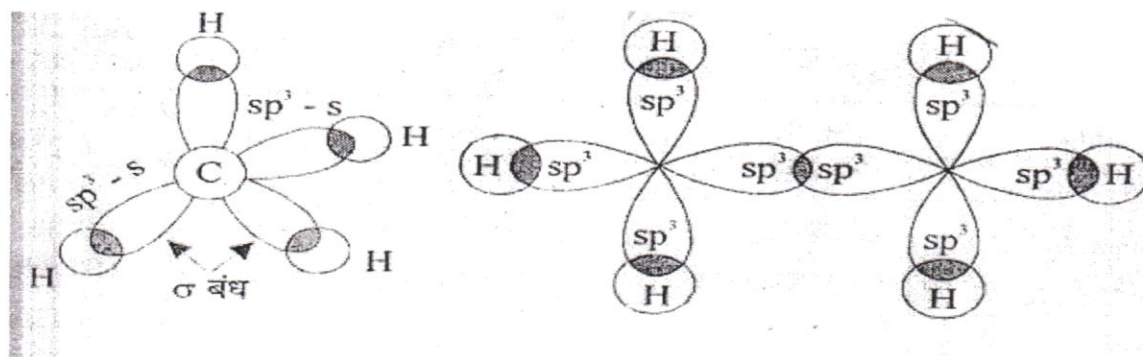

पैराफीनों का नामकरण -

पैराफीन के नामकरण के लिए निम्नलिखित तीन पद्धतियां प्रयुक्त की जाती हैं। तीनों ही प्रणालियों के अनुसार इस श्रेणी का अनुलग्न (suffix) ऐन (ane) है।

साधारण नाम (Trivial names) .

इस विधि के अनुसार इस श्रेणी के प्रथम चार सदस्यों के नाम उनके इतिहास के आधार पर रखे गये हैं। अर्थात् उन ऐल्कोहॉलों के नाम पर, जिनके द्वारा इन्हें प्राप्त किया गया है। जैसे ऐथिल ऐल्कोहॉल से प्राप्त होने वाले पैराफीन को ऐथेन कहते हैं। अगले सदस्यों के नाम इसमें उपस्थित कार्बन परमाणुओं की संख्या के अनुरूप ग्रीक या लैटिन संख्याक (numeral) के

आधार पर रखे जाते हैं। जैसे – पन्टेन (पेन्टा = 5), हेक्सेन (हेक्सा. = 6) कुछ ऐल्केनों के नाम दिये गये हैं।

सूत्र	ऐल्केन का नाम	सूत्र	ऐल्केन का नाम
CH_4	मेथेन	C_9H_{20}	नोनेन
C_2H_6	एथेन	$C_{10}H_{22}$	डेकेन
C_3H_8	प्रोपेन	$C_{11}H_{24}$	अनडेकेन
C_4H_{10}	ब्यूटेन, आइसो – ब्यूटेन	$C_{12}H_{26}$	डोडेकेन
C_5H_{12}	पन्टेन आइसोपन्टेन नियापन्टेन	$C_{20}H_{42}$ $C_{30}H_{62}$ $C_{40}H_{82}$	आइकोसेन ट्राइकान्टेन टेट्राकान्टेन
C_6H_{14}	हेक्सेन	$C_{50}H_{102}$	पेन्टाकान्टेन
C_7H_{16}	हेप्टेन		
C_8H_{18}	ऑक्टेन		

इस विधि के अनुसार सीधी श्रृंखला वाले हाइड्रोजन को नार्मल, शाखायुक्त हाइड्रोकार्बन को, जिसमें $(CH_3)_3$ CH- समूह या एक कार्बन परमाणु ऐसा हो जो दो मेथिल मूलक से संलग्न हो (द्वितीयक) उसे आइसो (Iso), जिसमें कार्बन परमाणु के तीन कार्बन युक्त समूहों से संलग्न हो, उसे तृतीयक और चतुष्क कार्बन परमाणु (quaternary carbon atom) युक्त हाइड्रोकार्बन को निओ (Neo) कहते हैं। हाइड्रोकार्बन के नाम के पहले उपर्युक्त पूर्वलग्न (perfix) लगा देते हैं जैसे –

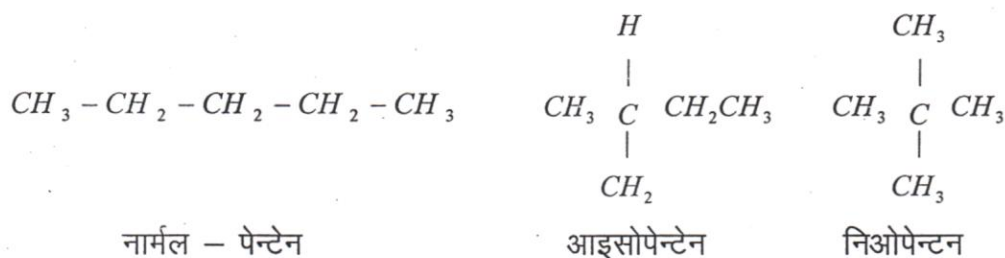

व्युत्पन्न नाम (Derived name)

इस विधि के अनुसार उच्चतर ऐल्केनों को मेथेन का व्युत्पन्न माना जाता है अर्थात् ये ऐल्केन मेथेन के एक या एक से अधिक हाइड्रोजन परमाणुओं के ऐल्किन मूलक द्वारा प्रतिस्थापन से प्राप्त होती हैं।

उदाहरणार्थ –

कुछ पौधों और जंतुओं से प्राप्त होने वाले मोम में ठोस संतृप्त हाइड्रोकार्बन के रूप में

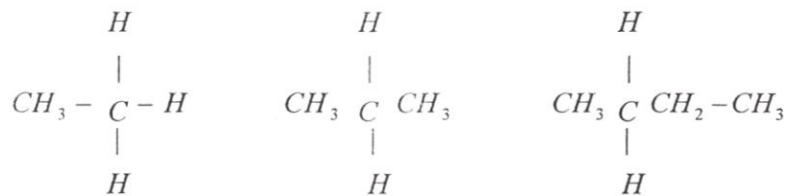

व्यवहार में इस विधि का प्रयोग साधारण पैराफीन के लिए बहुत कम होता है किन्तु जटिल (complex) यौगिक के लिए यह विधि अत्यधिक उपयोगी है। इस विधि के द्वारा नामकरण करने के लिए उस कार्बन परमाणु को जनक (parent) कार्बन परमाणु (मेथेन का कार्बन परमाणु) चुनते हैं। जो सबसे अधिक शाखा वाला होता है और इसमें संलग्न रहने वाले ऐल्किल मूलकों को बढ़ते हुए आकार के क्रम में लिखकर पैराफीन के नाम से अन्त में अनुलग्न मेथेन जोड़ देते हैं, जैसे -

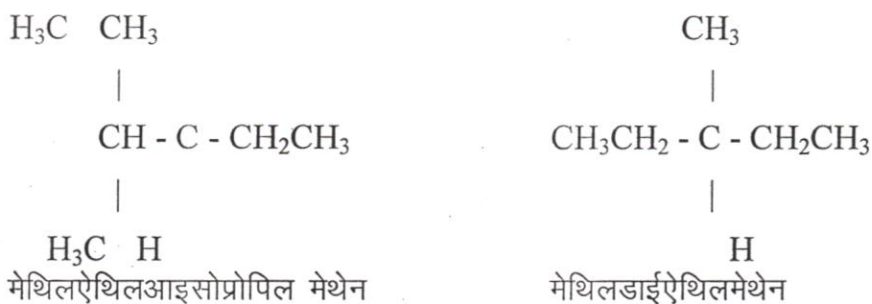

इस प्रणाली के द्वारा भी अत्यंत जटिल पैराफीनों का नामकरण नहीं किया जा सकता है, जैसे -

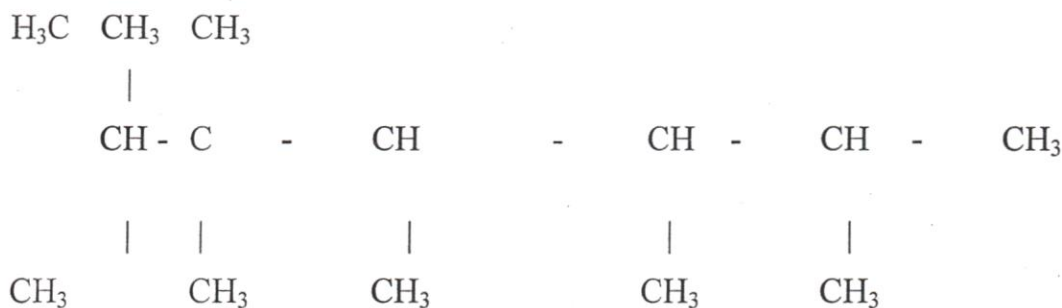

किन्तु उपर्युक्त प्रकार के यौगिकों का नामकरण IUPAC पद्धति के द्वारा सरलतासे किया जा सकता है।

आई.यू.पी.ए.सी. (IUPAC) पद्धति - इस पद्धति के अनुसार नामकरण निम्न पदों में किया जाता है।

(i) कार्बन परमाणुओं से बनी हुई बड़ी से बड़ी लगातार श्रृंखला को चुनते हैं और इस श्रृंखला में उपस्थित कार्बन परमाणुओं की संख्या के अनुरूप वाले n - ऐल्केन के नाम पर यौगिकों का नामकरण किया जाता है।

(ii) पार्श्व श्रृंखलाओं की स्थिति को दर्शाने के लिए चुनी हुई मुख्य श्रृंखला के कार्बन परमाणुओं का अंकन उस छोर से प्रारम्भ करते हैं, जिधर से पार्श्व श्रृंखला निकटतम होती है।

ऐल्केन बनाने की सामान्य विधियाँ –

1. किसी वसा अम्ल के निर्जल सोडियम लवण को सोडा लाइम के साथ गरम करके (प्रयोगशाला विधि) –

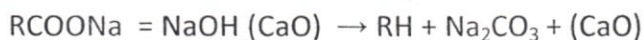

वसा अम्ल का सोडालाइम हाइड्रोकार्बन

सोडियम लवण



सोडियम एसीटेट मथेन



सोडियम प्रोपियोनेट एथेन

इस अभिक्रिया में कार्बोक्सिलिक अम्ल की कार्बन डाइऑक्साइड विलोपित होती है, इसलिए इस अभिक्रिया को विकार्बोक्सिलीकरण (decarboxylation) भी कहते हैं।

2. ऐल्किल हैलाइड से नवजात हाइड्रोजन द्वारा अपचयन में (प्रयोगशाला विधि) – ऐल्किल हैलाइड पर Zn व HCl या Zn-Cu युग्म एवं ऐल्कोहॉल, सोडियम अमलगम व जल, LiAlH_4 की क्रिया से ऐल्केन बनती है। LiAlH_4 से प्राथमिक एवं द्वितीयक $\text{R}-\text{X}$ का अपचयन किया जा सकता है जबकि $\text{N}_\alpha\text{BH}_4$ द्वि एवं तृतीयक $\text{R}-\text{X}$ का अपचयन करता है।

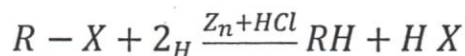

3. ऐल्किल हैलाइड से बर्ट्ज संश्लेषण द्वारा – जब ऐल्किन हैलाइड विशेषकर ब्रोमों अथवा आयोडो व्युत्पन्न के शूक ईथर में बने विलयन को सोडियम के साथ गरम करते हैं, तब ऐल्केन बनती है।

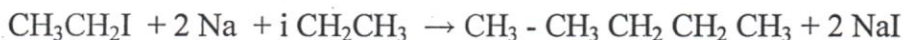

इस विधि द्वारा उच्चतर ऐल्केन बनाये जाते हैं।

एक से अधिक ऐल्किल हैलाइडों का मिश्रण लेने पर ऐल्केनों का मिश्रण प्राप्त होता है। दो प्रकार के ऐल्किल हैलाइड $\text{R}-\text{X}$ व $\text{R}'-\text{X}$ लेने पर तीन $\text{R}-\text{R}-\text{R}'$ व $\text{R}'-\text{R}'$ का मिश्रण प्राप्त होता है। इसको मिश्रित बर्ट्ज संश्लेषण कहते हैं।

शुष्क

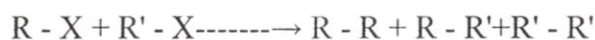

ईथर

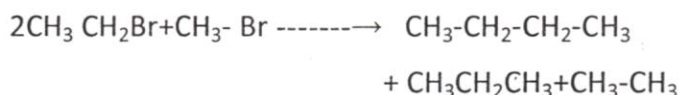

इस क्रिया को आयनिक एवं मुक्त मूलक दोनों क्रियाविधि से समझाया जा सकता है।

(i) आयनिक क्रियाविधि -



|

Br

(ii) मुक्त मूलक क्रियाविधि -

4. कोल्बे विधि द्वारा - किसी वसा अम्ल के सोडियम या पोटेशियम लवण के सांद्र जलीय विलयन का वैद्युत अपघटन करने पर ऐनोड पर ऐल्केन व CO_2 तथा पर H_2 ऐल्केन प्राप्त होता है। इस विधि द्वारा उच्चतर ऐल्केन बनायी जाती है। जिनमें कार्बन परमाणुओं की संख्या $2n-2$ होती है। यहां n = अम्ल में कार्बन परमाणुओं की संख्या है।

वैद्युत अपघटन



क्रियाविधि -

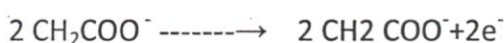

9. कॉरे हाउस ऐल्केन संश्लेषण (Corey House Alkane synthesis) - यह विधि उच्चतर ऐल्केन बनाने में काम आती है। इस विधि में कार्बधात्विक यौगिक लिथियम डाइऐल्किल क्यूप्रेट (गिलमान अभिकर्मक) की ऐल्किक हैलाइड के साथ युग्मन अभिक्रिया कराई जाती है। यह अभिक्रिया तीन पदों में सम्पन्न होती है।

- (i) ऐल्किक हैलाइड की लिथियम धातु के साथ ईथर में अभिक्रिया से ऐल्किल लिथियम बनता है।

ईथर



- (ii) ऐल्किल लिथियम को प्युप्रस आयोडाइड के साथ अभिकृत कराने पर लिथियम डाइऐल्किल क्यूप्रेट बनता है।

CH_3

|



- (iii) अब इस डाइऐल्किल क्यूप्रेट की अभिक्रिया दूसरे ऐल्किल हैलाइड के साथ कराने पर उच्च ऐल्केन प्राप्त होती है। इस पद में लिथियम डाइऐल्किल क्यूप्रेट के एक ऐल्किल समूह और दूसरे ऐल्किल हैलाइड के समूह के मध्य युग्मन होता है।

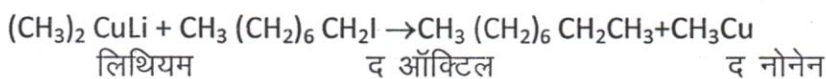

लिथियम

द ऑक्टिल

द नोनेन

डाइमेथिल क्यूप्रेट

आयोडाइड

इस अभिक्रिया द्वारा 2,2 - डाइमेथिल हेप्टेन निम्न प्रकार से बनाया जा सकता है।

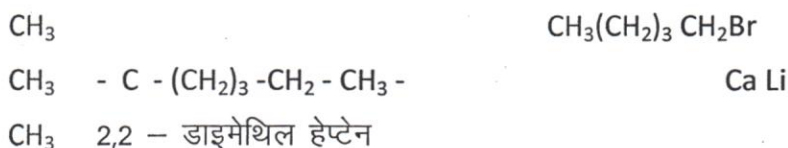
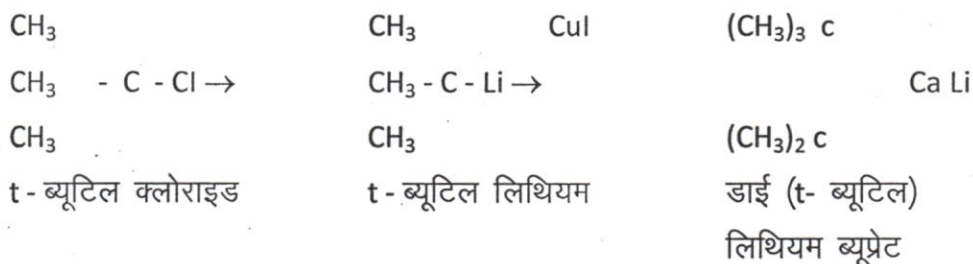

भौतिक गुण -

1. प्रथम चार सदस्य रंगहीन, गंधहीन गैसों और अगले उच्चतर सदस्य (C_{15} तक) रंगहीन द्रव एवं शेष सदस्य रंगहीन ठोस हैं।
2. ये जल में अविलेय हैं किंतु कार्बनिक विलायकों जैसे ऐल्कोहॉल, ईथर और बेंजीन में विलेय हैं। अणुभार की वृद्धि के साथ-साथ उनकी विलेयता कम होती जाती है।

- विशिष्ट घनत्व – अणुभार बढ़ने के साथ-साथ उनका विशिष्ट घनत्व धीरे-धीरे बढ़ता है और यह 0.78 पर लगभग स्थायी हो जाता है।
- गलनांक और क्वथनांक – इनके गलनांक और क्वथनांक अणुभार की वृद्धि के साथ नियमित रूप से बढ़ते हैं। कार्बन परमाणुओं की सम संख्या वाले हाइड्रोकार्बन के गलनांक कार्बन परमाणुओं की विषम संख्या होने पर श्रृंखला के दोनों सिरे एक दूसरे के विपरीत होते हैं, जिससे क्रिस्टल में ये अधिक निकटता से संतुलित (Packed) होकर अन्तराण्विक आकर्षण बढ़ा देते हैं। इसलिए सम संख्या वाले हाइड्रोकार्बनों के गलनांक अधिक होते हैं। इसक विपरीत यदि कार्बन परमाणुओं की संख्या विषम हो तो श्रृंखला के दोनों सिरे एक ही तरह स्थित होते हैं जिससे क्रिस्टलों में अणुओं के मध्य दूरी बढ़ जाती है। अतः आकर्षण वालों में कमी होने से उनके गलनांक थोड़े कम होंगे।



रासायनिक अभिक्रियाशीलता (Chemical reactivity) .

ऐल्केन अत्यंत स्थायी और निष्क्रिय यौगिक हैं। इनमें रासायनिक क्रियाशीलता बहुत कम होती है। साधारण अवस्था में इन पर अम्ल, क्षार एवं ऑक्सीकारकों का कोई प्रभाव नहीं होता। किंतु उच्च ताप पर ये ऑक्सीजन, क्लोरीन और ब्रोमीन के साथ सुगमता से क्रिया करते हैं। इनकी रासायनिक निष्क्रियता का कारण इनमें उपस्थित C-C तथा C-H बंध है, जिनकी बंध ऊर्जा क्रमशः 83 एवं 99 कि. कैलोरी / मोल है। सामान्य स्थितियों में ये अणु इतनी ऊर्जा प्राप्त नहीं कर पाते हैं। इसलिए ये रासायनिक अभिक्रियाएं प्रदर्शित नहीं करते। विशिष्ट परिस्थितियों में ऐल्केनों की कुछ अभिक्रियाएं निम्नलिखित हैं –

1. प्रतिस्थापन (Substitution) –

यह अभिक्रिया जिसमें यौगिक में उपस्थित किसी परमाणु या समूह के स्थान पर कोई अन्य परमाणु या समूह आ जाये एवं यौगिक की आंतरिक रचना में कोई परिवर्तन न आये, प्रतिस्थापन अभिक्रिया कहलाती है।

ऐल्केनों में प्रतिस्थापन के कुछ मुख्य उदाहरण हैं – हैलोजनीकरण, नाइट्रीकरण, क्लोरोसल्फोनीकरण आदि।

(अ) हैलोजनीकरण (Halogenation) – जब ऐल्केन पर हैलोजन (विशेष रूप से Cl₂ या Br₂) की क्रिया सूर्य के धुंधले प्रकाश या पराबैंगनी प्रकाश या उत्प्रेरक की उपस्थिति में अथवा उच्च ताप पर होती है, तब ऐल्केन के हाइड्रोजन परमाणु एक-एक करके हैलोजन परमाणुओं से प्रतिस्थापित हो जाती है। इस अभिक्रिया में प्रायः हैलोजनीकृत ऐल्केनों का मिश्रण प्राप्त होता है। उदाहरणार्थ मेथेन के क्लोरोनीकरण से निम्न पदार्थ बनते हैं –

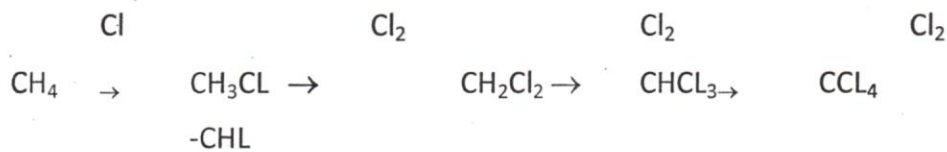

ऐल्केनों के साथ हैलोजन की क्रियाशीलता का क्रम निम्न है –

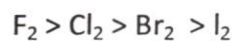

और ऐल्केनों से हाइड्रोजन परमाणुओं की विस्थापनीयता का क्रम निम्नलिखित होता है—



उदाहरणार्थ : जब आइसोब्यूटेन का क्लोरोनीकरण 300°C पर किया जाता है, तो - 2-क्लोरो - 2-मेथिलप्रोपेन (II), 1 क्लोरो - 2-मेथिल प्रोपेन (I) की अपेक्षा अधिक मात्रा में बनता है।

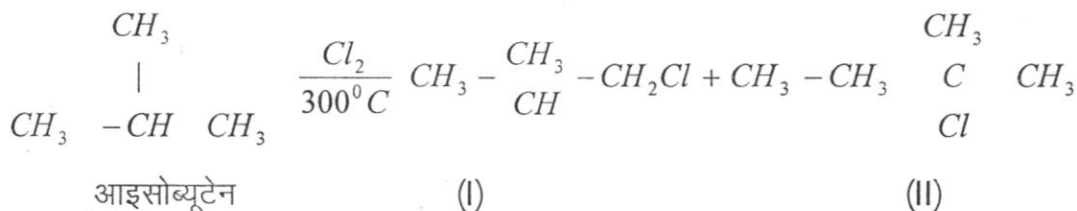

ब्रोमोनीकरण की क्रिया भी इसी प्रकार होती है। आयोडीनीकरण की अभिक्रिया उत्क्रमणीय (reversible) होती है, क्योंकि अभिक्रिया में बना हुआ HI एक अपचायक है, जो ऐल्किल हैलाइड को पुनः ऐल्केन में अपचयित कर देता है। इसलिए यह क्रिया किसी ऑक्सीकरण जैसे आयोडिक अम्ल, नाइट्रिक अम्ल, मरक्यूरिक ऑक्साइड आदि की उपस्थिति में की जाती है। जो उत्पन्न हुए हाइड्रोआयोडिक अम्ल को ऑक्सीकृत कर देते हैं।



फ्लुओरीनीकरण की क्रिया में विस्फोट होता है, इसलिए फ्लुओरिन व्युत्पन्नों को ब्रोमो या आयोडो व्युत्पन्नों पर HgF₂ की क्रिया से प्राप्त करते हैं।



मुक्त मूलक क्रियाविधि – Free Radical Reaction

यह अभिक्रिया मुक्त मूलक क्रियाविधि द्वारा सम्पन्न होती है। ऐल्केनों को हैलोजनीकरण एक श्रृंखला अभिक्रिया है, जिसके तीन प्रमुख पद हैं।

- (i) श्रृंखला प्रारम्भ करने वाला पद।
- (ii) श्रृंखला संचरण पद
- (iii) श्रृंखला समापन पद
- (i) श्रृंखला प्रारम्भ करने वाला पद – इस पद में हैलोजन अणु का उच्च ताप अथवा पराबैंगनी प्रकाश की उपस्थिति में समांश विखण्डन होता है तथा दो हैलोजन मुक्त मूलक बनते हैं।

उच्च ताप या



पराबैंगनी प्रकाश

हैलोजनों की अभिक्रिया क्षमता का क्रम निम्न प्रकार है –



(ii) श्रृंखला संचरण पद – हैलोजन मुक्त मूलक ऐल्केन अणुओं में से एक हाइड्रोजन परमाणु को विस्थापित एक एक ऐल्किल मुक्त मूलक एवं एक हाइड्रोजन हैलाइड का अणु बनाता है।

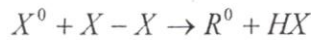

ऐल्किल मुक्त मूलक हैलोजन अणु से अभिक्रियाओं के बार-बार होने से युक्त मूलक बनते रहते हैं एवं श्रृंखला चलती रहती है।

(iii) श्रृंखला समापन पद – इस पद में क्रियाकारी कण आपस में अभिक्रिया कर अभिक्रिया का समापन कर देते हैं।

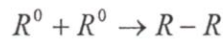
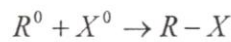
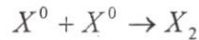

किसी ऐल्केन में विभिन्न प्रकार के हाइड्रोजन परमाणुओं की हैलोजन के प्रति क्रियाशीलता का क्रम निम्न प्रकार है।

तृतीयक हाइड्रोजन > द्वितीय हाइड्रोजन > प्राथमिक हाइड्रोजन

(ब) नाइट्रीकरण (Nitration) .

यह वह अभिक्रिया है, जिसमें हाइड्रोजन परमाणु नाइट्रो मूलक द्वारा प्रतिस्थापित हो जाता है।

साधारण ताप पर ऐल्केन सांद्र नाइट्रिक अम्ल से क्रिया नहीं करती है इसलिए इनमें नाइट्रीकरण उच्च ताप पर वाष्प अवस्था में होता है।

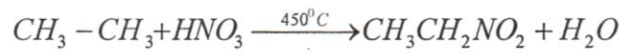

एथेन

नाइट्रोएथेन

उच्चतर ऐल्केन में सभी संभावित मोनो नाइट्रो व्युत्पन्न बनते हैं जिनमें से कुछ तो सीधे ही बनते हैं। और कुछ श्रृंखला के विखण्डन (fission) के बाद बनते हैं। उदाहरणार्थ – n-ब्यूटेन के नाइट्रीकरण पर निम्न उत्पाद बनते हैं।

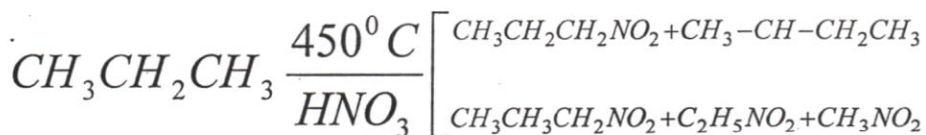

(स) सल्फोनीकरण (Sulphonation)

हाइड्रोजन के सल्फोनिक मूलक (-SO₃H) द्वारा विस्थापन होने के सल्फोनीकरण कहते हैं। पैराफीन (ऐल्केन) श्रेणी के निचले सदस्यों का सल्फोनीकरण सरलता से नहीं होता है। समूह H₂SO₃ जिसमें SO₃ आधिक्य में विलेय रहता है) के साथ 400°C पर होता है।

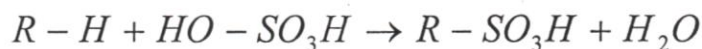

ऐल्किल एल्फोनिक अम्ल

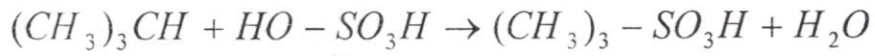

आइसोब्यूटेन

तृ व्यूटिल सल्फोनिक अम्ल

2. ताप अपघटन, ऊष्मीय अपघटन या भंजन (Pyrolysis, thermal decomposition)–

जब पैराफीन की वाष्प को 500°C के ऊपर ऑक्सीजन की अनुपस्थिति में गरम किया जाता है, तब ये छोटे-छोटे अणुओं के एक मिश्रण में अपघटित हो जाते हैं। इस मिश्रण में सरल पैराफीन, असंतृप्त हाइड्रोकार्बन एवं कार्बन उपस्थित होते हैं। पैराफीन या अपघटन दो प्रकार से होता है ।

- (अ) एक प्रकार के अपघटन से C-C बंध का विखण्डन (Fission) होता है और सरल पैराफीन एवं ओलिफिन बनते हैं।
- (ब) दूसरे प्रकार के अपघटन में C-H बंध टूटता है और ओलिफिन बनती है, जिसमें कार्बन परमाणुओं की संख्या वहीं होती है जो ऐल्केन में होती है।

“वह प्रक्रिया, जिसमें ऊष्मा के प्रभाव में जटिल (Compelx) हाइड्रोजन सरल अणुओं में परिवर्तित हो जाते हैं, भंजन कहलती है।”

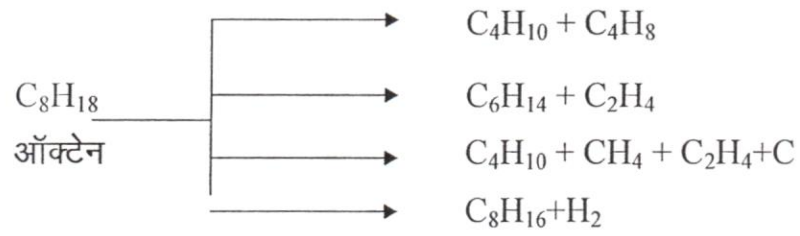

पैराफीनों का ऊष्मीय उपघटन एक महत्वपूर्ण अभिक्रिया है। इसका उपयोग भारी तेल (Heavy oil) को कृत्रिम पेट्रोल में परिवर्तित करने के लिए किया जाता है।

Coordination in plants

Prof. Jaydip Mandal
Professor of Botany

RIE, Bhopal

Plant hormones are a group of naturally occurring, organic substances which influence physiological processes such as growth, differentiation and development at low concentrations. Auxins were first discovered in the light sensitive seedlings of the oat (*Avena sativa*). **F.W. Went (1929)** succeeded in extracting from seedling tips a compound, originally named as Wuchsstoff which could stimulate the growth of decapitated plantlets. When the compound was applied to one side of a seedling, it bent towards the light due to increased elongation. **Went** proposed the name auxin for the curvature inducing plant hormone present in the tip, which was later shown to be indole-3-acetic acid (IAA) (Fig.1). IAA is synthesized from tryptophan or indole primarily in leaf primordia, young leaves and developing seeds. The auxins have been implicated in the control of many diverse plant functions including cell enlargement, cell division, root initiation, tropistic responses, apical dominance, leaf senescence, leaf and fruit abscission, inhibition of axillary buds (lateral buds), vascular tissue differentiation (organ differentiation), fruit setting and growth (parthenocarpic fruit formation), fruit ripening, flowering, growth of flower parts, promotes femaleness in dioecious flowers, weeding, callus induction etc.

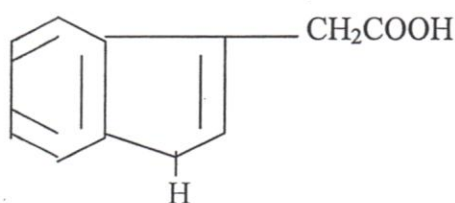

Fig. 1 Indole-3-acetic acid (IAA)

Tropic curvatures can be explained on the basis of differential auxin concentrations. In phototropism the auxin concentration on the unilluminated side of the shoot is higher than that on the illuminated portion.

i) Biological effects of auxins in vegetative multiplication can be demonstrated in the following way. The vegetative propagation of stems, roots, and leaves of numerous plant species may be accelerated and improved by hormones.

Expts.1 Demonstration of the effect of auxins as root inducing substances

Materials: Take least six young leafy cutting of 4-6 inch long, are made from each species. Usually it is better to use softwood cuttings with two or three leaves intact.

Aqueous solutions (0.05 to 0.1 percent IBA) may be used but commercial preparations using talc (hydrous magnesium silicate) as the carrying agent in a mixture of 1 part of growth hormone powder to 1000 to 5000 parts of clay or talc are the most practical.

Procedure: Wet the cut ends of the half of the cuttings of each species for examples, rose, carnation, *Coleus Chrysanthemum* & willow and treat them with talc only and the other half with the talc hormone preparation. Dip the cuttings about 2.5cm of the stem into a stronger solution (0.05 to 0.1 percent) for about 1 second. Young leafy cuttings may be soaked 1 to 2 hr in a 0.005 percent solution of IBA, while woody cuttings should be soaked for 1 to 2 hr in 0.01 percent IBA. Plant the cuttings the treated ones and several untreated controls, in separate pots of sand or peat, in a shaded, warm (37°C) situation. Record observation for about 10 days and examine for root formation.

Table: **Effect of auxin in vegetative multiplication**

Name of species	conc.of hormone(%) (IBA)	Duration for root initiation (days)	No. of roots/stem cutting
1. Rose (<i>Rosa</i> sp.)	a) 0.005 b) 0.05 c) 0.1		
2. Chrysanthemum sp.	a) 0.005 b) 0.05 c) 0.1		
3. Coleus sp.	a) 0.005 b) 0.05 c) 0.1		

The following questions may be asked to the pupils.

- i) Is there any optimum concentration where rooting of stem cuttings is best ?
- ii) If the concentration of hormone were increased linearly, what would have been the effect on cuttings?
- iii) Whether all the cuttings would exhibit the similar rooting pattern?
- iv) Why does stimulation of rooting of cuttings occur at specific concentration of hormone?

Discussion:

Students should understand that plants do possess endogenous levels of hormones. Hormones regulated different processes in the cells. Expression of gene regulates differentiation of organs. Environmental factors do play a vital role in differentiation along with proteins that have regulatory roles.

Conclusion:

Specific hormonal combination in optimum concentration under optimal environmental conditions especially at temperature in the range of 25-37°C, induce root initiation of stem cuttings of several species.

Experiment 2: Effect of auxin on growth of shoots

Students may germinate soaked oat or mustard seeds in paper cups of vermiculite or moist sand kept in the dark. When the coleoptiles emerge and are about 1-1.5 cm high, cut off about 3 mm of the tips of several with a sharp, sterile razor or the edge of a cover slip. Then apply a bit of lanolin paste to the cut off surfaces of the coleoptiles (coleoptile stump). Decapitate an equal number of coleoptiles, apply lanolin to which 0.1 percent indoleacetic acid has been added. Prepare this by dissolving 100 mg of IAA in 2ml of absolute ethyl alcohol. Add this solution to 100g of lanolin paste and mix thoroughly so that the auxin is evenly distributed in the paste. Set aside coleoptiles from which tips are not removed. Place all the shoots (that is cut tips with lanolin, cut tips with lanolin plus indoleacetic acid and normal tips) near a source of unilateral light. Record observation and after 24 hr, students should measure the angle of curvature in all three sets of plants. Which part of the coleoptiles seems to produce a growth regulating substance? Which part of the coleoptiles seems sensitive to light?

Some students may also plan experiments to find out whether terminal buds produce a substance that inhibits the growth of lateral buds.

- Easily prepared auxin formula

Mix thoroughly 0.1 g of β (beta) indoleacetic acid (IBA) with 1 ml of 70 percent ethyl alcohol and then add this to 50g of hydrous lanolin. A smooth paste should be made. If you wish to have a color for identification, add a pinch of carmine powder to tint the paste red.

Experiment 3: Why do stems of seedlings in darkness grow in length more rapidly than those in bright light?

Materials: Take about 20 seeds of each of any three of the beans, peas, soybeans, radish, squash, corn grains, or sunflower. Also, select a good potato tuber, which has terminal bud (eye). Eight ordinary flower pots, 4 to 6 inches size, needed as containers through reasonably good soil of one kind to fill the pots.

Plant 10 seeds of each species selected in two pots observe daily and record the information. The seeds should be planted about 3 weeks before the demonstration is to be used, keeping one pot in as near total darkness as possible and the other in full sunlight. All should be watered equally. The temperature should be the same i.e. average room temperature (about 22°C or 70° F). The potato tuber should be cut with one eye or bud to each piece, planting one or two pieces in each of two pots of soil, same as for the seeds. The potato pieces should be planted 5 weeks before the demonstration is to be used in class. Record the observation for the whole growth period students should observe the plants after they have grown for the periods. **The stems of all plants which grew in darkness may be three to four times as long as those which grew in bright light.**

The observation by the students may be followed by question, i) Why are the stems of plants longer when grown in darkness than those which grew in bright light? The most common responses is that the plants in darkness grow longer stems in order to search for light. Some other responses include: plants, which grew in darkness, lack the green pigment (chlorophyll), while those exposed to light are green. Leaves of all the plants, which grew in darkness excepting corn, are very small and poorly developed as compared to those, which grew in bright light. The stems of all plants, which grew in darkness, appear to have weaker stems than those, which grew in light. Student's attention is to be directed to why stems grow faster in darkness than in light.

Explanation: The inference needs to be drawn that auxins accumulate more rapidly in darkness than in bright light and that growth in stem length increases as the hormone content increases.

Experiment 4: Apical Dominance

Use two coleus plants of the same variety and age, which have been propagated vegetatively. Use one as the control, and remove the terminal from the other, keeping the two plants growing under same conditions under sunlight. Within a week or two appreciable growths of lateral branches from axillary buds will likely be evident. If suitable tree species are available in the school grounds or near by, a field trip for making observations on trees and shrubs in the winter condition is quite worth while. When student can make these observations under natural conditions instead of just reading about them or being told about them in a lecture, the educational value accruing is as great as difference between day and night. **This kind of teaching complements and enhances the natural curiosity of the individual for understanding his/her environment.**

Experiment 5: Effect of leaves and buds on the growth of stem cuttings.

Select healthy *Coleus*, *Geranium* or other herbaceous stem cuttings which have several internodes. In some, remove all the leaves, in others, remove the terminal buds and the growing tips; in a third group remove only the lower leaves.

Table: Influence of organs on rooting of stem cuttings.

Kinds of stem Cuttings in moist sand	Duration of root formation(days)	No. of roots /per cutting
1. Stem cuttings devoid of all leaves		
2. Cuttings without terminal buds		
1. Cuttings with its lower leaves removed		
4. Control cutting (with all leaves and buds)		

Discussion: There is indication that root-forming substances may be made in buds and leaves and transported to the region where new growth (root formation) is stimulated.

Conclusion: Students should interpret the data in the Table. They need to signify the role of different organs of cuttings in the initiation of roots.

Gibberellic acid (GA₃)

Overview:

- The effects of gibberellic acid in rice attacked by a fungus (*Gibberella fujikuroi*) were originally observed and described in 1898. In 1926 a Japanese botanist **Kurosawa** observed that rice plants infected with a fungus *Gibberella fujikuroi* grew much more rapidly than uninfected rice plants. In 1938, what proved later to be a complex of growth substances was isolated and identified as gibberellins(GAs). Young infected rice plants grew unusually tall and died of the “foolish seedling” disease. Gibberellic acid(GA₃) a fungal product, is one of the most promising and widely available compounds composing the gibberellins. Gibberellic acid is effective in aqueous solutions in concentrations 1 to 20 parts per million. The most important GA in higher plants is GA₁, which is the GA primarily responsible for stem elongation. GAs are synthesized from glyceraldehydes-3-phosphate, isopentenyl diphosphate(IPP), in young tissues of the shoot and developing seed. Some effects:
 - Stem elongation-The gibberellins(GA₁) induced hyperelongation is caused by increased mitotic activity(cell division) as well as cell elongation(enlargement of cells). This produces tall, as opposed to dwarf, plants.
 - bolting in long day plants - GAs cause stem elongation in response to long days.
 - induction of seed germination - GAs can cause seed germination in some seeds that normally require cold(stratification) or light to induce germination
 - Enzyme production during germination-GA stimulates the production of numerous enzymes, notably α -amylase, in germinating cereal grains
 - Gibberellins can also induce flowering and break dormancy in certain plants by eliminating the necessity of exposure to long days or periods of low temperature.
 - Fruit setting and growth- this can be induced by exogenous applications in some fruit(e.g.,grapes)

- Induction of maleness in dioecious flowers

With some plants, remarkable results may be obtained.

Activity: 1 To demonstrate the effects of gibberellins on elongation of plants.

Materials: Dwarf and tall varieties of peas (*Pisum sativum*), beans (*Phaseolus* sp.) or corn (*Zea mays*). It may of interest to examine the effects of gibberellins on other dwarf plants such as zinnias, marigolds (*Tagetes*), sweet pea (*Lathyrus*), snapdragons (*Anthirrhinum*) etc.

i) Germinate seeds of these plants in paper cups and allow the seedlings to grow for 2-4 weeks. Each unit (paper cup/small earthen pot(s) can accommodate 6-8 plants.

ii) Gibberellic Acid solutions:

Prepare stock solution by weighing out 1 mg of the GA powder, dissolve in a few drops of ethyl alcohol and mix into 100 milliliters of distilled water. Prepare aqueous solutions of GA (gibberellic acid containing 0.01, 0.1, 1.0, 10.0 mg/l out of stock solution.

Procedure: Apply directly 1 ml of each of the GA solution using pipette/glass rod to a young leaf of each of five dwarf variety plants and five tall variety plants. Application of the gibberellic acid to the plants may be repeated in 5 days.

Observation: Measure the height of each plant daily for 3 weeks. Take the average length for each experimental unit containing 5 plants each of dwarf / tall varieties. Record your result and present them graphically.

Table: The effect of gibberellic acid on elongation

Concentration of GA ₃ ml/L	Days									
	Length in millimeters									
	3		9		12		15		20	
	T	D	T	D	T	D	T	D	T	D
0										
0.01										
0.1										
1.0										
10.0										

T – tall variety; D – dwarf variety

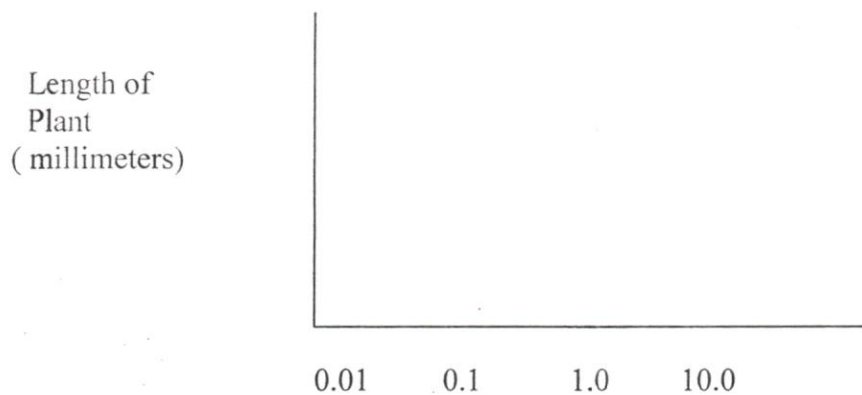

Fig. The effect of GA₃ mg/L on elongation

Impact: Students could appreciate the effect of GA₃ on elongation of plant. Differentiation between control and experimental plants may reveal the wonder works of chemical substances, which regulate the chemical processes unfurling the growth and differentiation. GA₃ regulates the expression of genes, thus gene regulatory proteins induce or inhibit the growth and development.

Activity 2: Effect of GA₃ on germination of barley seeds

- Material: i) Collect barley seeds. Germinate 5 barley seeds in each of the three paper cups/earthen pots containing moist sand/vermiculite/soil.
 ii) Prepare different concentrations of GA₃ solution such as 0.01, 0.1., 1.0 & 10 mg/l out of stock solution of GA₃.

Procedure: Apply 5 ml, each of the GA₃ solution in each of the three experimental cups/earthen pots. Place all the cups in warm place 28-32°C (70°F) in shaded areas not directly exposing to sunlight.

Observation: Record your observation and calculate the average % of germination and plot the result graphically.

Table: Effect of GA₃ on germination of barley (*Hordeum vulgare*) seeds

Concentration of GA ₃ (ml/l)	% of seed germination			
	Days			
	5	10	15	20

0.01				
.1				
1.0				
10.0				

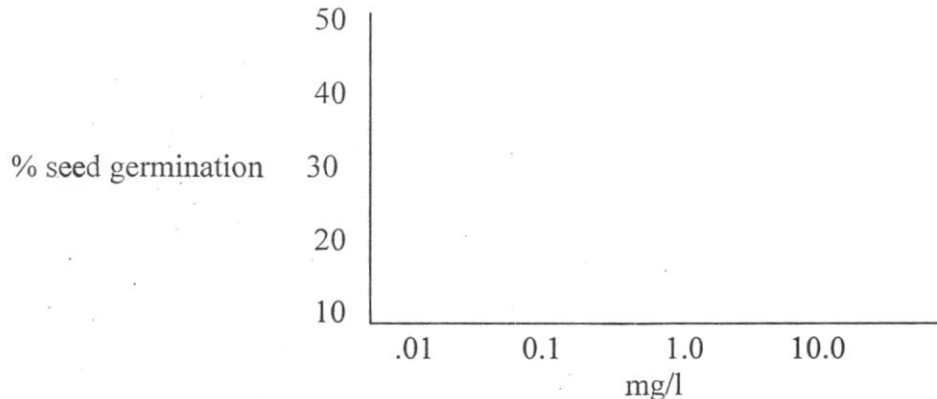

Fig: Effect of GA₃ on seed germination

Cytokinins (CKs)

CKs are adenine derivatives characterized by an ability to induce cell division in tissue culture in presence of auxin. The most common cytokinin base in plants is zeatin. CKs also occur as ribosides and ribotides. CK is synthesized through the biochemical modification of adenine. It occurs in root tips and developing seeds. Some effects:

- Cell division- exogenous application of CKs induce cell division in the presence of auxin (e.g., fruits, shoot tips)
- Morphogenesis- in tissue culture and crown gall CKs promote cell initiation
- Growth of lateral buds- CK applications can cause the release of lateral buds from apical dominance
- Leaf expansion resulting solely from cell enlargement
- Delays leaf senescence
- May enhance stomatal opening in some species
- Chloroplast development- the application of CK leads to accumulation of chlorophyll and promotes the conversion of etioplasts into chloroplasts

Ethylene(C₂H₄)

The gas ethylene is synthesized by most tissues in response to stress. In particular, it is synthesized in tissues undergoing senescence or ripening. Being a gas , ethylene moves by diffusion from its site of synthesis.

Some effects:

- Triple response: Darkgrown seedlings exhibit decrease in stem elongation, a thickening of the stem and a lateral growth(triple response).
- Maintenance of the apical hook in seedlings
- Stimulate defense responses in response to injury or disease
- Release from dormancy
- Shoot and root growth and differentiation
- Adventitious root formation
- Leaf and fruit abscission
- Flower induction in some plants
- Induction of femaleness in dioecious flowers
- Flower opening
- Flower and leaf senescence
- Fruit ripening

Abscisic acid(ABA)

ABA is synthesized from glyceraldehyde-3-phosphate via isopentenyl diphosphate(IPP) and carotenoids in roots and matured leaves, particularly in response to water stress. Seeds are also rich in ABA which may be imported from the leaves or synthesized in situ.

Some effects:

- Stomatal closure- water shortage brings about an increase in ABA which leads to stomatal closure
- ABA inhibits shoot growth but has less effect on, or may promote, root growth. This may represent a response to water stress
- ABA induces storage protein synthesis in seeds
- ABA counteracts the effect of gibberellins on α -amylase synthesis in germinating cereal grains
- ABA affects the induction and maintenance of some aspects of dormancy in seeds

Energy sources and Conservation

Prof M. Bapat

Email: mnbapat@gmail.com

Activity 1

Take a pendulum and give it a swing of reasonably large amplitude. Now observe the amplitude of the pendulum. You may notice that the amplitude of oscillation remain same even after several oscillation. This amplitude at the maximum displacement represents potential energy and we notice that potential energy remains almost same (except for small decrease in amplitude due to air friction). Similarly, kinetic energy is maximum at its lowest or stable position. If you can measure velocity at its location, you can notice that the velocity remains almost same even after several oscillations. This velocity is related to kinetic energy that is same or conserved. Simple pendulum is one of the finest and convincing example for conservation of energy and also that there can be change in its form.

Activity 2

Take a spring and suspend it to a hinge so that it hangs in a vertical plane. Suspend a suitable weight on the loose end. The weight will stretch the spring a little in the process. We are using energy possessed by the weight and transferring it to the spring. The stretched spring represents presence of potential energy in it. If we remove the weight spring takes its original position. In other words energy was neither lost nor created in the spring. What all happened was change in the form of energy.

Activity 3

Take a cell of 2 V and connect it to an electrolytic capacitor (electrolytic capacitors possess generally a higher capacity and that its terminals are named with + and -). These may be of any colour and shapes, but in our country it is blue coloured (sometimes orange also) and cylindrical in shape. These are one of the most efficient devices of storing electricity. But unless handled properly it can be a curse too. How much it can store electrical energy (in the form of charge), is obtained from $Q = CV$.

Here Q is charge that the capacity acquires when connected to a DC battery. Assuming V and C remain same. Now make connection as under.

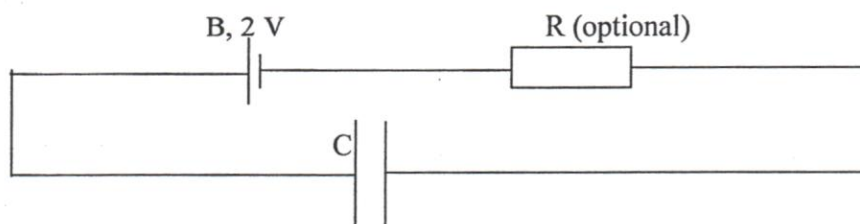

Box item

Key and resistance box is optional. Resistance cause change in the time charging of the capacitor.

On the basis of previous experience tell how many connecting wires are used? 3 or 7? There is also something wrong in connection.

What C indicates is capacity but not electrolytic? Hence the circuit should have been as under-

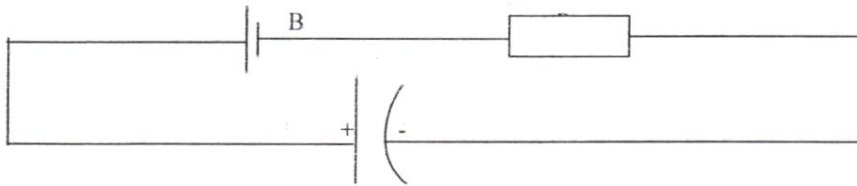

Figure is an electrolytic capacitor representation. Straight line corresponds to positive terminal and curved as negative terminal.

Now charge the capacitor for say 5 min and then connect its terminals to a galvanometer. You will find a throw in galvanometer. The quantum of throw will be almost same as charge on capacitor does not change and is not lost.

Some questions

Is it understandable from activity 1 to 3 that energy cannot be created or destroyed?

What is name given to a device that affects changes in the form of energy?

How would you identify a capacitor is electrolytic type?

Is it possible to do away with a key? Use resistance box.

Two volt battery is sometime drained of its capacity. Why does it happen? Do we have any remedy for it?

Review

Probably it just indicated that conversion from one form to another form happens. But in the case of electronics it is very difficult to appreciate even this much. In electrical analysis we can indirectly conclude conservation of energy by passing current through electrolytes.

Illustration 4

Again I wish to convince you conservation of energy through a daily life experience. Take two big calibrated cylindrical jars and pour water in them to different levels, as shown. The two jars can be connected through a tube. It indicates that both jars will attain same level if same amount of liquid is poured in to them. For this reason we take similar jars and fill them with water to say 200 ml in one and 100 ml in the other. The water will flow from one jar to other till water level in both the jar is same (i.e. 150 ml). The PE before transfer of water was total energy possessed by the system which is $mgh = 200 \times 10^{-6} \times 9.8 \text{ H} = 19.6 \times 10^{-4} \text{ H}$ for one jar and $9.8 \times 10^{-4} \text{ H}$ for the other jar. So total of these is $29.4 \times 10^{-4} \text{ H}$. Similar calculation can be done on attaining equilibrium for the composite system. It is $300 \times 10^{-6} \times 9.8 \text{ H} = 29.4 \times 10^{-4} \text{ H}$. Here we have assumed that both jars are put at same but sufficient height so that change in water level in the jars can be neglected.

We can notice that the principle of conservation of energy is verified.

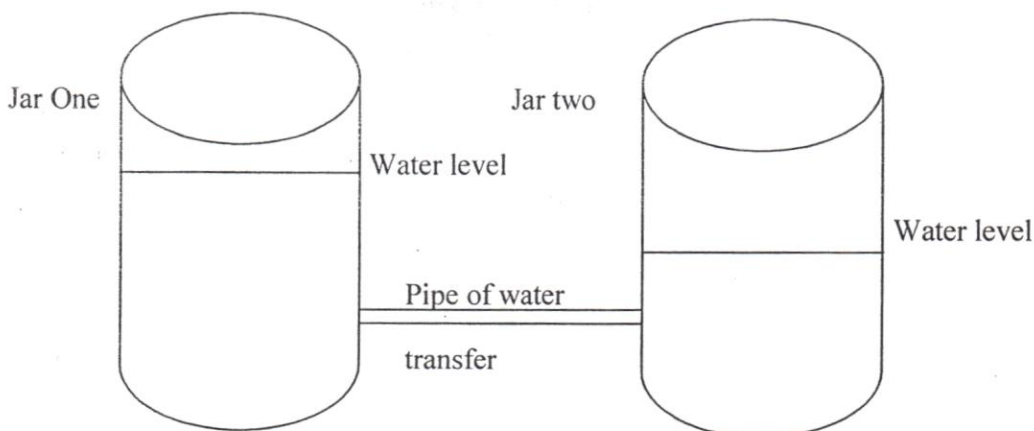

Conservation of electrical energy has not many supporting simple experiments. I will just indicate a few.

- a. It is beyond the comprehension of class we are dealing with. A resonant circuit where all magnetic energy located is the coil. From the coil goes to capacitor in the form of electrical energy. The process (of electric energy to magnetic energy and vice versa) continues for quite some time (ideally it should continue for infinite period).
- b. Electrically charged capacitor with different charges, when connected to share energy is one of the worst examples of conservation of energy (charge transfer causes dissipation of energy in the form of heat). Hence it may be avoided as an example if possible. Still in one particular situation it can show conservation of energy. Can you try, what that can be?

Task

One- Take a ceramic magnet and find its strength with the help of compass needle or any justifiable instrument. Now break that magnet. Now again find if the total field produced is same. If yes give reason. If not, give the reason.

Two- Collect as many bar magnets as possible. Find individual fields produced by them. Sum the fields. Now bring all pieces together. Does the final result agree with the data obtained for individual components? What precaution is needed?

Suggest few more tasks.

Backdrop

Through evolutionary processes, the miracle of life has given rise to a rich tapestry of biological diversity; or biodiversity. There are three aspects of biodiversity:

- (a) genetic diversity within species that enables organisms to evolve and adapt to new conditions,
- (b) species diversity that refers to the number and kind of organisms distributed within an ecosystem, and
- (c) ecosystem diversity that refers to the variety of habitats and communities interacting in complex relationships.

During earth's history, life has proliferated and diversified, with species filling the myriad niches of ecosystems. Through the many climatic and structural changes of a dynamic earth, life continued to adjust and prosper. Today there are approximately 1.4 million known species with over five million yet to be identified by conservative estimates, living everywhere from the boiling waters of undersea vents to the frozen Antarctic.

What is Biodiversity ?

- Biodiversity is the variability among living organisms from all sources, including terrestrial, marine, and other aquatic ecosystems and the ecological complexes of which they are part; this includes diversity within species, between species, and of ecosystems.
- Biodiversity forms the foundation of the vast array of ecosystem services that critically contribute to human well-being.
- Biodiversity is important in human-managed as well as natural ecosystems.
- Decisions humans make that influence biodiversity affect the well-being of themselves and others.

Where is biodiversity ?

Biodiversity is essentially everywhere, ubiquitous on Earth's surface and in every drop of its bodies of water. The virtual omnipresence of life on Earth is seldom appreciated because most organisms are small (<5 centimeters); their presence is sparse, ephemeral, or cryptic, or, in the case of microbes, they are invisible to the unaided human eye.

- ***Spatial Patterns of Biodiversity***

Documenting spatial patterns in biodiversity is difficult because taxonomic, functional, trophic, genetic, and other dimensions of biodiversity have been relatively poorly quantified. Spatial Patterns of Biodiversity include: Hotspots, Biomes, 1 Biogeographic Realms, Ecosystems, and Ecoregions. While

and distribution of all components of biodiversity, there are, nevertheless, many patterns and tools that decision-makers can use to derive useful approximations for both terrestrial and marine ecosystems. Most macroscopic organisms have small, often clustered geographical ranges, leading to centers of both high diversity and endemism, frequently concentrated in isolated or topographically variable regions (islands, mountains, peninsulas). Biomes and biogeographic realms provide broad pictures of the distribution of functional diversity.

- **Temporal Patterns of Biodiversity**

Knowledge of patterns of biodiversity over time allow for only very approximate estimates of background rates of extinction or of how fast species have become extinct over geological time. A mismatch exists between the dynamics of changes in natural systems and human responses to those changes. Shifts to different regimes may cause rapid substantial changes in biodiversity, ecosystem services, and human well-being.

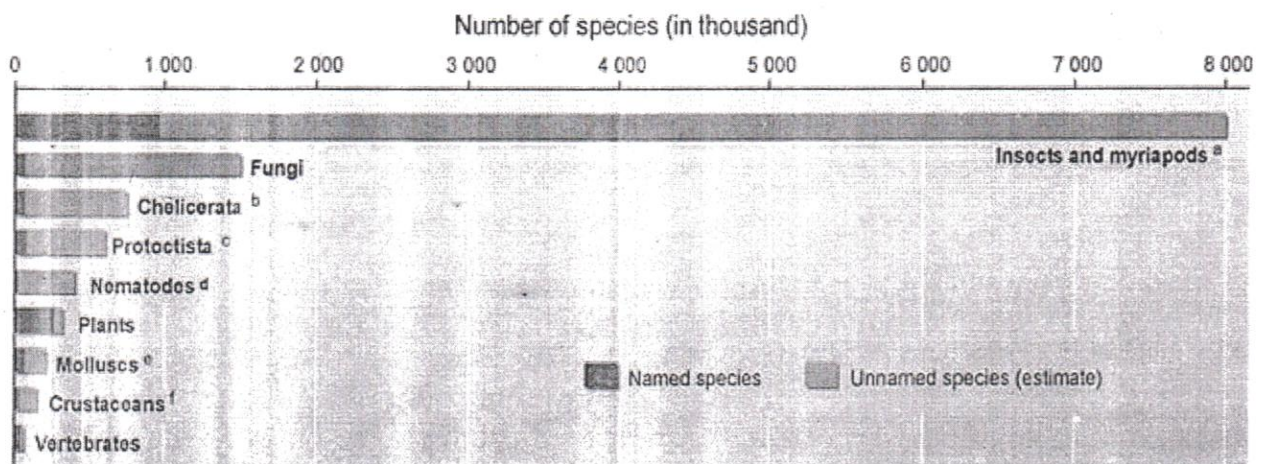

- ^a Myriapods: centipedes and millipedes
- ^b Arachnids
- ^c Algae, slime mold, amoeboids, and other single-celled organisms (excluding bacteria)
- ^d Roundworms
- ^e Snails, clams, squids, octopuses, and kin
- ^f Barnacles, copepods, crabs, lobsters, shrimps, krill, and kin

Source: Millennium Ecosystem Assessment

What is the link between biodiversity and ecosystem services?

Biodiversity plays an important role in ecosystem functions that provide supporting, provisioning, regulating, and cultural services. Species composition matters as much or more than species richness when it comes to ecosystem services. Ecosystem functioning, and hence ecosystem services, at any given moment in time is strongly influenced by the ecological characteristics of the most abundant species, not by the number of species. Local or functional extinction, or the reduction of populations to the point that they no longer contribute to ecosystem functioning, can have dramatic impacts on ecosystem services. Changes in biotic interactions among species—predation, parasitism, competition,

negative alterations of ecosystem processes. Many changes in ecosystem services are brought about by the removal or introduction of organisms in ecosystems that disrupt biotic interactions or ecosystem processes. As in terrestrial and aquatic communities, the loss of individual species involved in key interactions in marine ecosystems can also influence ecosystem processes and the provisioning of ecological services.

- **Supporting Services**

- Biodiversity affects key ecosystem processes in terrestrial ecosystems such as biomass production, nutrient and water cycling, and soil formation and retention—all of which govern and ensure supporting services (high certainty).
- Region-to-region differences in ecosystem processes are driven mostly by climate, resource availability, disturbance, and other extrinsic factors and not by differences in species richness (high certainty).
- Even if losses of biodiversity have small short-term impacts on ecosystem function, such losses may reduce the capacity of ecosystems for adjustment to changing environments (that is, ecosystem stability or resilience, resistance, and biological insurance) (high certainty).

- **Regulating Services**

- Invasion resistance - The preservation of the number, types, and relative abundance of resident species can enhance invasion resistance in a wide range of natural and semi-natural ecosystems (medium certainty).
- Pollination - Pollination is essential for the provision of plant-derived ecosystem services, yet there have been worldwide declines in pollinator diversity (medium certainty).
- Climate regulation - Biodiversity influences climate at local, regional, and global scales, thus changes in land use and land cover that affect biodiversity can affect climate. In addition to biodiversity within habitats, the diversity of habitats in a landscape exerts additional impacts on climate across multiple scales. Some components of biodiversity affect carbon sequestration and thus are important in carbon-based climate change mitigation when afforestation, reforestation, reduced deforestation, and biofuel plantations are involved (high certainty). The major importance of marine biodiversity in climate regulation appears to be via its effect on biogeochemical cycling and carbon sequestration.
- Pest, disease, and pollution control - The maintenance of natural pest control services, which benefits food security, rural household incomes, and national incomes of many countries, is strongly dependent on biodiversity. The marine microbial community provides critical detoxification services, but how biodiversity influences them is not well understood.

Why is Biodiversity Important ?

The biodiversity found on Earth today is the result of approximately 3.5 billion years of evolution. Until the emergence of humans, the earth supported more

dominance of humans, biodiversity has begun a rapid decline, with one species after another suffering extinction ¹.

The maintenance of biodiversity is important for the following reasons:

- **Ecological stability**

- Each species performs a particular function within an ecosystem. They can capture and store energy, produce organic material, decompose organic material, help to cycle water and nutrients throughout the ecosystem, control erosion or pests, fix atmospheric gases, or help regulate climate.
- Ecosystems provide support of production and services without which humans could not survive. These include soil fertility, pollinators of plants, predators, decomposition of wastes, purification of the air and water, stabilisation and moderation of the climate, decrease of flooding, drought and other environmental disasters.
- Research show that the more diverse an ecosystem the better it can withstand environmental stress and the more productive it is. The loss of a species thus decreases the ability of the system to maintain itself or to recover in case of damage. There are very complex mechanisms underlying these ecological effects.

- **Economic benefits to humans**

- For all humans, biodiversity is first a resource for daily life. Such 'crop diversity' is also called agrobiodiversity.
- Most people see biodiversity as a reservoir of resources to be drawn upon for the manufacture of food, pharmaceutical, and cosmetic products. Thus resource shortages may be related to the erosion of the biodiversity.
- Some of the important economic commodities that biodiversity supplies to humankind are:
 - **FOOD** : crops, livestock, forestry, and fish
 - **MEDICATION**: Wild plant species have been used for medicinal purposes since before the beginning of recorded history. For example, quinine (Used to treat malaria) comes from the bark of the Amazonian tree Cinchona tree; digitalis from the Foxglove plant (chronic heart trouble), and morphine from the Poppy plant (pain relief).
 - According the National Cancer Institute of the USA, over 70 % of the promising anti-cancer drugs come from plants in the tropical rainforests. Animal may also play a role, in particular in research. It is estimated that of the 250,000 known plant species, only 5,000 have been researched for possible medical applications.
 - **INDUSTRY**: fibres for clothing, wood for shelter and warmth. Biodiversity may be a source of energy (such as biomass). Other industrial products are oils, lubricants, perfumes, fragrances, dyes, paper, waxes, rubber, latexes, resins, poisons and cork can all be derived from various plant species. Supplies from animal

also be used as a mode of transportation.

- TOURISM & RECREATION: biodiversity is a source of economical wealth for many areas, such as many parks and forests, where wild nature and animals are a source of beauty and joy for many people. Ecotourism in particular, is a growing outdoor recreational activity.

- **Ethical reasons**

The role of biodiversity is to be a mirror of our relationships with the other living species, an ethical view with rights, duties, and education. If humans consider species have a right to exist, they cannot cause voluntarily their extinction. Besides, biodiversity is also part of many cultures' spiritual heritage.

Why are we losing Biodiversity ?

- When people think about problems with our Biodiversity, most tend to primarily think about the loss of creatures such as the Panda or Snow Leopards. This mainly has come about as a result of the large publicity given to these species at risk.
- Whilst the loss of individual species catches our attention, it is the degradation and obvious loss of forests, wetlands and coral reefs, to name but a few, that pose the greatest threat to our biodiversity. Taking forests as an example, a large portion of Europe's original forested area has been lost during the last century primarily as a result of the industrial revolution. Other areas of the world, particularly South America's Amazon, continue to suffer from deforestation as a result of industrial processes.
- Global changes such as climate change only add to the pressures being faced by our ecosystems. Changes to the timing of flowering and migration patterns, as well as the distribution of species have been observed across the planet. These types of changes can alter natural food chains and as a result indirectly affect the sensitive natural patterns and processes established within each ecosystem, for example mating season no longer coinciding with the natural increase in food availability for birds.
- The change in land use is also another reason behind natural habitat loss. In particular when humans convert natural ecosystems into agricultural land in order to meet local demands or for profit. This human influence is still the biggest direct cause of biodiversity loss and can be seen most evidently within the Amazonian Forest of South America.
- The loss of biodiversity destabilizes ecosystems and weakens their ability to deal with natural disasters, such as floods, and other impacts caused by human process, such as pollution. Unsustainable use and over-exploitation of ecosystems continues to be the predominant threat of Earth's biodiversity. In order to reverse the current impacts arising as a result of human processes on our biodiversity, humans need to bring their demands on nature in line with nature's ability to produce and in turn dispose only at the rate which nature is capable of absorbing at.

What are we doing about the loss of biodiversity?

- While it is clear that the measures taken to conserve biodiversity over the past are no longer adequate to deal with growing pressures including climate change, we benefit today from the foresight behind these actions, which has helped to mitigate some of the pressures and retain more options for a new, coordinated and prioritized approach to biodiversity conservation planning.
- **The provincial government** has undertaken several initiatives aimed at conserving biodiversity including creation of new parks and protected areas, completing strategic land use plans, establishing old growth management areas, designating Identified Wildlife Management Areas to manage species at risk, biodiversity provisions under the *relevant Acts*.
- The federal government has developed a variety of initiatives including developing appropriate policies to maintain a healthy environment by conserving ecosystems and preventing loss of species and genetic diversity.
- **Many local and regional governments** have also taken steps to account for the importance of biodiversity protection in their planning and zoning processes.
- Individuals can also play an important role in conserving biodiversity, including for example those who have placed conservation covenants on their private property in order to preserve natural values for future generations.

How can you help save biodiversity?

- ***Be good to your climate***

All of us are affected, in one way or another by Climate Change. But where as we can wrap up warmer, cool our living rooms, or jump on a bus, train or plane to escape the worst of some climatic impacts, many species are not so mobile, not so inventive, and cannot so easily adapt to the changes brought on by our massive emissions of greenhouse gases. Species that have no-where to run are gradually being pushed towards extinction. You can help to switch off global warming in many different ways.

- ***Do not buy bad souvenirs***

You are on your holidays, you're in the souvenir shop, and boy does "that" look nice. It's so unusual, it would make a great talking point when you get home. But is it made from the skin, fur, bone, shell, beak or hooves of an endangered species?

If it is, and if you buy it, you're just going to encourage whoever killed it, crafted it or made it, to do it all over again. Plus, most likely you're going to break an international law when you go through customs, and that's always a situation to avoid. By avoiding certain wildlife products and carefully watching what you buy (always ask!), you can prevent bringing many species closer to the edge of extinction.

At the same time you'll also be encouraging local suppliers to stock only legal and sustainable products. So what should you look out for? You can check out our holiday guide here. But the golden rule is this: if you doubt it, don't buy.

- ***Save forests by buying good wood***

protection. Buy wood and wood products that come from a sustainable legal source. One of the main causes of this destruction is illegal logging, which is fed by the high demand for timber and timber products that end up in our shops and your homes. By questioning where your garden furniture or wooden flooring comes from - you can in fact halt the chainsaws and support those suppliers who are doing it right! Reduce your paper consumption and use recycled paper. Using 100% recycled paper saves 24 trees per tonne of paper. Check out some tips on how to be paper efficient.

- **Buy sustainable seafood**

80% of the world's biodiversity lives in the sea and there is still much to be discovered. At least 100 million unnamed species live on the ocean floor alone. Yet beneath the ocean's surface there are constant scenes of absolute and utter devastation. It's a fact that the diversity of marine life is being systematically eroded by overfishing.

We are bulldozing, scooping, sieving and raking our oceans for all their worth... And leaving nothing but a wasteland behind. Nowadays 75% of the world's fisheries are fully or over exploited. Our insatiable demand for, and unscrupulous extraction of fish constitutes the single biggest threat to the overall health of the marine environment and its ability to support life on Earth. But there are ways and means to keep our oceans alive. At restaurant or at home, all you have to do is choose fish which are sustainable, avoiding endangered like Bluefin Tuna or Northsea cod. Take a stand against unsustainable fishing and check out these seafood guides.

How to Conserve Biodiversity?

- Before we discuss the way to achieve biodiversity conservation, we first need to know the reason why we actually need to conserve the existing biodiversity. It is believed that an area with higher species abundance has a more stable environment compared to an area with lower species abundance. We can further claim the necessity of biodiversity by considering our degree of dependency on the environment. We depend directly on various species of plant for our various needs. Similarly, we depend on various species of animals and microbes for different reasons. Biodiversity serves our need for different types of food, raw materials, fuel, etc.
- There are two major ways in which biodiversity conservation is practiced, namely - in-situ conservation and ex-situ conservation.

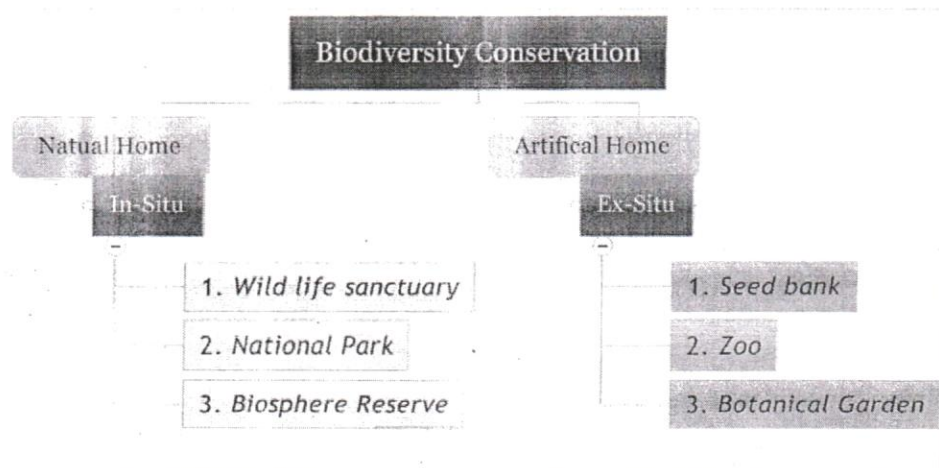

***In situ* conservation**

As the name suggests, it is carried out locally. It is basically impossible to save the entire ecosystem for protecting a few endangered species. Hence, came the requirement of localizing the process of conservation. This gave rise to the identification of areas known as 'biodiversity hotspots'. They are the regions of high species diversity and the species are distinctively specific to that region. Thus, conservation becomes relatively easier for a limited area of land. It can be considered as a process of optimizing the process of conservation as many species can be protected with fewer efforts. There are 34 biodiversity hotspots identified all over the world which occupy a very small area but comparatively account for a huge species diversity.

In India, we have legally protected areas which help in conservation of various species that includes – National parks, sanctuaries, biosphere reserves, etc. Here animals live in their natural habitat and have freedom of movement. Hunting and other means of animals exploitation in such regions are banned. Many of these regions today are struggling to save the endangered animals. The most common example that we see is that of tiger protection at places like the Corbett National park.

***Ex situ* conservation**

It is majorly a man-made technique in which the endangered species are usually put in enclosures, away from their natural habitat. For examples, Zoological parks and wildlife safaris are such areas in which the animals are bound in an area and are taken care off. With recent advancement in technology, ex – situ conservation has taken a whole new meaning. With the help of cryopreservation techniques, gametes of some endangered species are conserved for fertilization in labs to give rise to new organisms.

Activities

1. Take the students to local parks / Sanctuaries / Gardens / water bodies and ask them to enlist 5 each of birds, fishes, insects, herbs, trees, grasses and shrubs to make them aware of the biodiversity around them.
2. Organize quiz at school level.

Key Words

Biodiversity Hotspots, *Ex situ* and *In situ* conservation, Gene bank, Climate Change, IUCN, Extinct species, ecosystem services

Exercises

A. Fill up the blanks.

1. Udanti WLS is situated in-----
2. The term 'Biodiversity' was coined by
3. Conservation within the natural habitat is.....
4. IUCN head quarter is at
5. State Bird of Chhattisgarh is
6. State animal of Chhattisgarh is ...

B. Multiple choice questions

1. National bird of United States is
A. Dove B. Crow C. Bald D. Teeter
2. Viruses are
A. Unicellular B, Multicellular C. Acellular D. Bicellular
3. Variation among specie or within specie is known as
A. Diversity B. Biological change C. Taxonomic Change D. Global variation
4. Name of kinfdom to which pea plant belongs is
A. Plantae B. Protists C. Fungi D. Animalia

WORLD WIDE WEB RESOURCES

Biodiversity and Conservation - <http://darwin.bio.uci.edu/~sustain/bio65/Titlepage.htm>.

A hypertext book by P. J. Bryant. The chapters on "Global patterns of biodiversity" and "Values of biodiversity" seem particularly relevant.

The Virtual Library of Ecology, Biodiversity, and the Environment - <http://conbio.rice.edu/vl/browse/%20>

Serves as a gateway to many other websites related to biodiversity.

Biodiversity and Biological Connections Web Server - <http://muse.bio.cornell.edu/%20>

Serves as a gateway to extensive lists of websites providing information about specific organisms, professional groups, and other resources.

Hall of Biodiversity - <http://research.amnh.org/biodiversity/index.html%20>

Resources associated with the Hall of Biodiversity at the American Museum of Natural History.

The Tree of Life - <http://phylogeny.arizona.edu/tree/phylogeny.html%20>

The gateway to an extensive, distributed Internet project with information about biodiversity.

Forests and Biodiversity - <http://www.igc.apc.org/wri/enved/trends/for-home.html%20>

This page is associated with the World Resources Institute.

Forests and Biodiversity Links - <http://forests.org/forsite.html%20>

An extensive collection of links categorized into "biodiversity," "sustainable forestry," and many other topics.

World Resources Institute: Biodiversity - <http://www.wri.org/biodiv/index.html%20>

An extensive collection of sites relating to biodiversity.

National Biodiversity Profiles - <http://www.wcmc.org.uk:80/nbp/>

Enables users to search for biodiversity information and highlights for specific countries.

<http://eelink.net/EndSpp/Endangered.html%20>

Provides access to images, policies, information, links, and other resources.

National GAP Analysis Program

<http://www.gap.uidaho.edu/gap/%20>

A USGS site on A Geographic Approach to Planning for Biological Diversity

Biodiversity Programs - <http://nrmnhwww.si.edu/biodiversity/biopro.htm%20>

Describes various biodiversity programs of the Smithsonian Institution.

Environment Australia: Biodiversity Group - <http://www.anca.gov.au/%20>

Provides access to publications, programs, and information servers.

REFERENCES

Braus, J. (Ed.). (1994). "WOW! Windows on the wild: A biodiversity primer." Washington, DC: World Wildlife Fund. [ED 402 151]

Braus, J., & Champeau, R. (1994). *Windows on the wild: Results of a national biodiversity education survey.* Washington, DC: World Wildlife Fund. [ED 398 075]

Braus, J., & O'Reilly, D. (1994). *Celebrating life's diversity.* "Science Scope," 17(5), insert.

BSCS. (1993). "Developing biological literacy: A guide to developing secondary and postsecondary biology curricula." Colorado Springs, CO: BSCS Innovative Science Education.

Foster-Turley, P. (1996). "Making biodiversity conservation happen: The role of environmental education and communication." Washington, DC: GreenCOM. [ED 415 096]

Myers, N. (1996). *The biodiversity crisis and the future of evolution.* "The Environmentalist," 16, 37-47.

NPS. (1990). "Biological diversity: Makes a world of difference. A curriculum for teachers and interpreters." Washington, DC: National Park Service, Dept. of Interior. [ED 326 450]

National Research Council. (1996). "National science education standards." Washington, DC: National Academy Press.

Pitman, B., Braus, J., & Asato, L. (1998). "The biodiversity collection: A review of biodiversity resources for educators." Washington, DC: NAAEE. [SE 061 391]

Tuxill, J. (1998). "Living strands in the web of life: Vertebrate declines and the conservation of biological diversity" (Worldwatch Paper 141). Washington, DC: Worldwatch Institute.

St. Antoine, S., & Runk, J. V. (1996). *Biodiversity-from sea to shining sea.* "Science Scope," 20(3), 34-37. [EJ 533 264]

Wilson, E.O. (1992). "The diversity of life." New York: W.W. Norton.

WWF. (1995). "Web of life: exploring biodiversity. An educator's guide." Washington, DC: World Wildlife Fund. [ED 391 683]

Control and coordination in animals

Prof. V.K. Kakaria

Head, DESM, RIE Bhopal

Dr. Sudhi Shrivastava

Assistant Prof., RIE Bhopal

Coordination – is the working of various organs of body of an organism in a proper manner to produce appropriate reaction to a stimulus.

Stimulus: - is the change in the environment to which an organism responds and reacts is called stimulus

Response: Any behavior of a living organism that results from an external or internal stimulus is called response. All living organisms need to respond to changes in the environment.

Stimulus > detection > co-ordination > response

Need of control and coordination in an organism:

There are various organs in an organism. These organs must be carefully controlled and coordinated for the survival of an organism. Control and coordination in animals takes place by two systems of the body i.e.

- **Nervous System: the nervous system helps us to understand things around us.** The System of human body that receives the stimulus/information from surrounding environment, understand it and transmit impulse/message to the effector organ for controlling movement and feeling between brain and other parts of the body.
- Nervous system helps different parts of our body to communicate and allows brain to control what is going on.
- Without nervous system our body would be a mess. It wouldn't know anything that what is going in and outside our body and wouldn't be able to control our body.
- Nervous system is made up of bunch of interconnecting nerve cells or neurons.

- **Endocrine System:** Endocrine system is made up of a whole collection of glands and it does very important functions. It regulates controls and coordinates number of our body's functions.

But How?

Our nervous system uses electricity to orchestrate all sorts of things in our body, while our endocrine system does even more through the wonder of chemicals. Now the question arises....

What are these chemicals and Where do they come from?

These chemicals are secreted from cells, tissues and organs called **endocrine glands**. These chemicals are called **hormones**. The hormones travel throughout our body through bloodstream, and act as chemical messengers .

What makes our nervous system?

- A neuron is the microscopic structural and functional unit of nervous system. The **human brain** is made up of approximately 100 billion (100,000,000,000) neurons. These neurons or nerve cells are connected with each other to form complicated network of interconnecting neurons which forms brain and spinal cord.

The **brain** is an organ as it controls the functions of the body. The **brain** is the most **important** organ in the human body. It controls and coordinates actions and reactions, allows us to move, think and feel, and enables us to have memories and feelings – all the things that make us human.

- Neurons are the longest cell of the human body

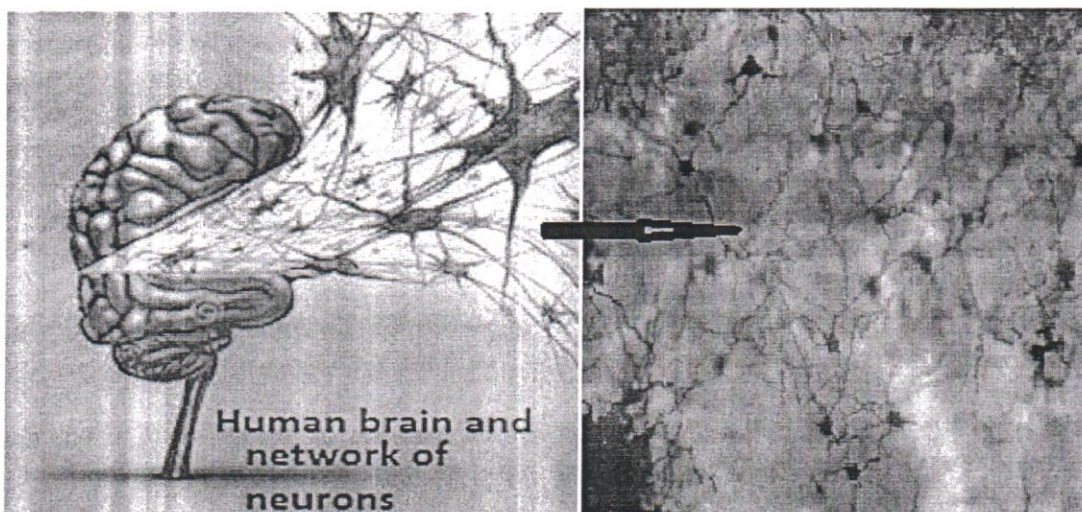

Fig: indicating the network of neuron in brain

Structure of neuron

Each neuron is composed of 3 major parts, cell body, dendrites and axon.

The **cell body** contains nucleus cytoplasm and other cytoplasmic organelles like mitochondria, Golgi body etc.

Dendrites are short branched fibers that project out of the cell body. They are connected to other neurons with their axons and receive nerve impulses.

Axon is elongated fiber of cell body. Its ends are branched . It conducts message away from the cell body. They relay nerve impulses to distant part of the body. Some axons are covered by mayelin sheath. This is made up of schawann cells.

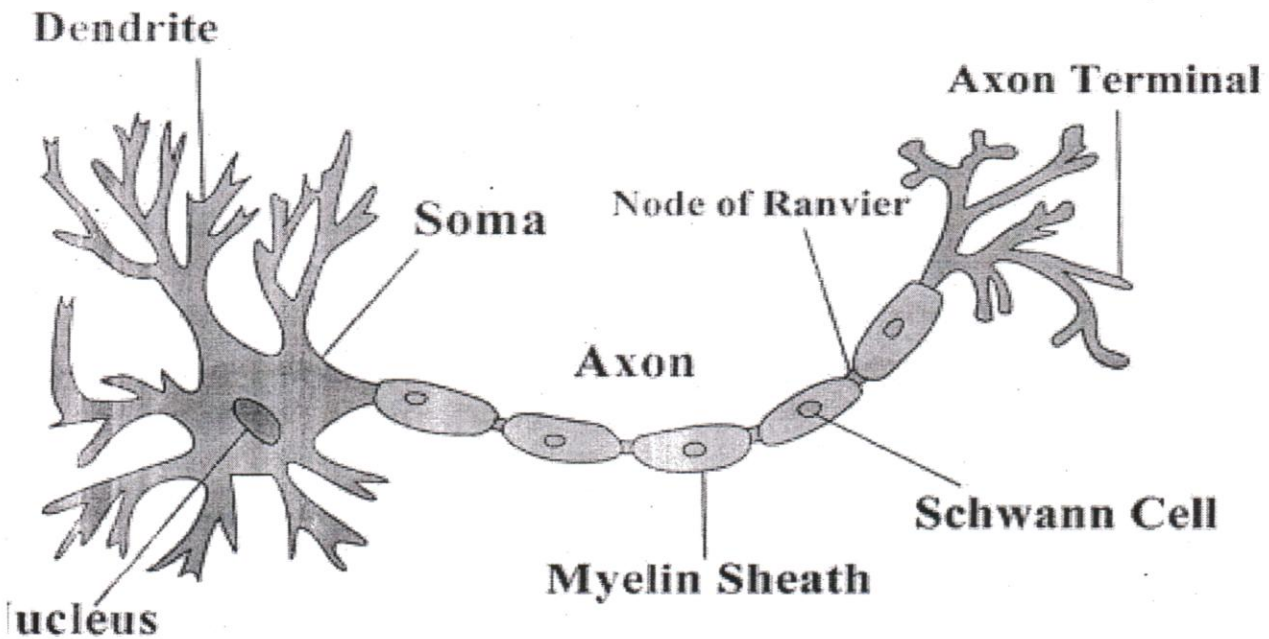

Synapse: A neuron connects with others at junctions called synapses. The junction between two nerve cells, consist of a minute gap across which impulses pass by diffusion of a neurotransmitter.

Or

Synapse is the point of contact between the terminal branches of axon of one neuron with the dendrite of other neuron called synapse.

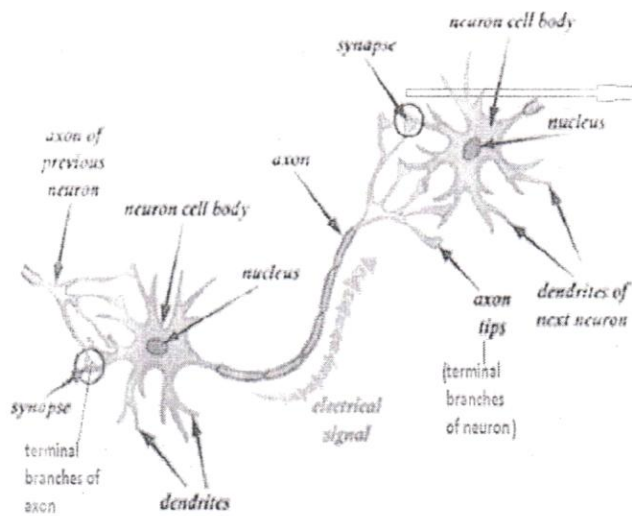

Fig: indicating synapse (junction of two neurons) the point of contact between the terminal branches of axon of one neuron with the dendrite of other neuron

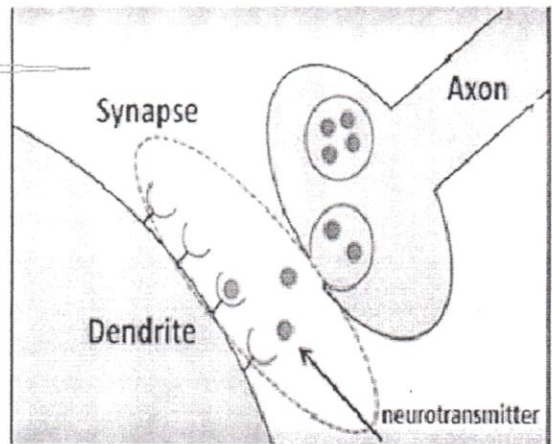
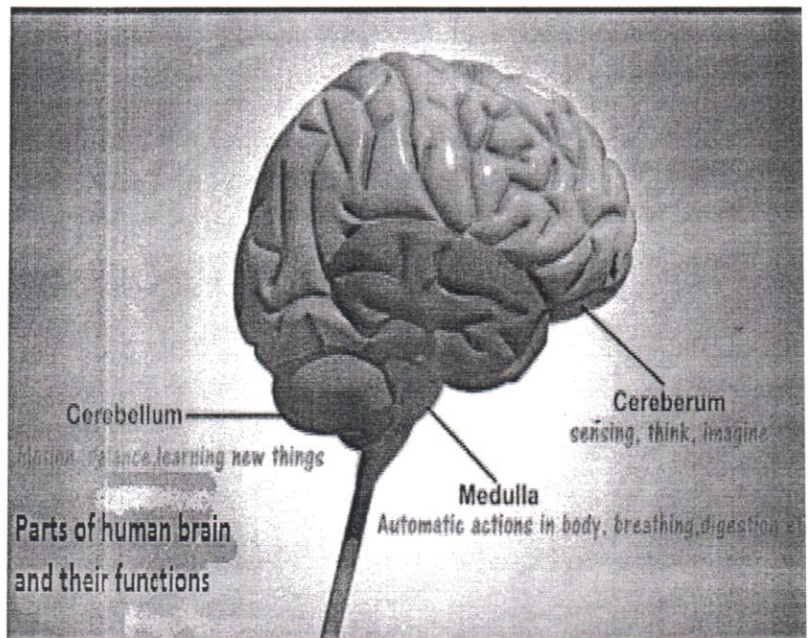
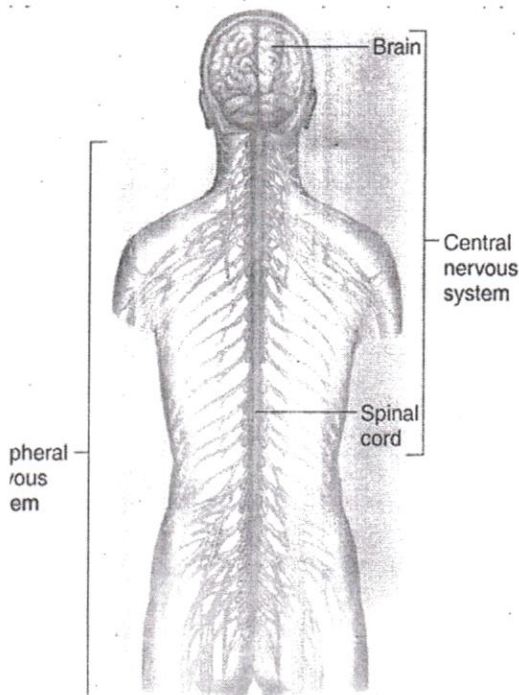

fig: indicating synapse between dendrite of one neuron and axon of other neuron

Working: Neurons are responsible for transmitting message from brain to body parts and vice versa.

- When receptor sense anything, a chemical reaction is triggered
- This chemical reaction causes an electrical impulse in dendrites, which travels through cell body of neuron to axon ending.

Parts of Nervous Syst



Nervous system is mainly composed of

- a) brain b) Spinal cord c) Nerves

In addition to these five sense organs (Nose, Eyes, Ears, and Tongue & Skin) are also part of Nervous system and play very important role in nervous system.

Brain and spinal cord forms CNS and nerves forms the peripheral nervous system.

a) Brain: it controls all the functions in the human body. It is surrounded by skull or cranium.

Cerebrospinal fluid is filled between brain and the skull.

- Cranium and CSF protects the brain from external shocks.
- Human brain has 3 parts –
 - a) Forebrain (Cerebrum)
 - b) Midbrain
 - c) Hind brain

Functions

Forebrain or Cerebrum

- It is most complex part of brain.
- This is thinking part of the brain
- It controls memory, sensation, movement, feelings etc.
- Different parts of cerebrum are responsible for different jobs.

Mid brain

- It controls cerebral reflexes like change in size of pupil, blinking of eye.

Hind brain

- It controls involuntary actions. (beating of heart, breathing)
 - Three parts
 - ➔ Pons – regulate respiratory functions
 - ➔ Cerebellum - Controls posture, balance, motion etc.
 - ➔ Medulla – controls involuntary action, heartbeat, blood pressure, swallowing etc.

Spinal cord

- Spinal cord is started at medulla (hind brain) and extend downwards.
- It is enclosed by a bony structure called vertebral column at back of the body.
- Spinal cord carries message between brain and body via nerves.
- It controls spinal reflexes.

Peripheral nervous system : It is composed of

a) cranial nerves b) spinal nerves c) visceral nerves

a) Cranial nerves (12 pairs) comes out of the brain and go to the sense organs and muscles in the head region.

b) Spinal nerves (31 pairs) comes out of spinal cord and go to sense organs and muscles which are below the head region. Carry message to brain from spinal cord.

c) Visceral nerves :- Comes out of brain and spinal cord and go to internal organs (like heart, kidney etc)

Receptors : Touching an hot object is an urgent and dangerous situation for us. We need to detect it , and respond to it. How do we detect that we are touching a hot object All information from our environment is detected by the specialized tips of some nerve cells are called receptors. These receptors are group of cells present in our sense organs such as inner ear, nose, tongue, eye and skin.

- The environmental information's received by the dendritic tip of a nerve cell (receptor) starts a chemical reaction which converts all type of information's (chemical, light, sound etc) into electrical impulses.
- This electrical impulse travel from dendrite to cell body, then along axon to its end.
- At the end of the axon, the electrical impulse sets off the release of some chemicals.
- These chemicals cross the gap/synapse and start a similar electrical impulse In dendrite of the next neuron.
- A similar synapse finally allows delivery of such impulses from neurons to other cells. Such as muscles or glands.
- Thus it is clear that neurons tissue is made up of an organized network of nerve cells or neurons, and is specialized for conducting information via electrical impulses from one part of the body to another.

(Electrical

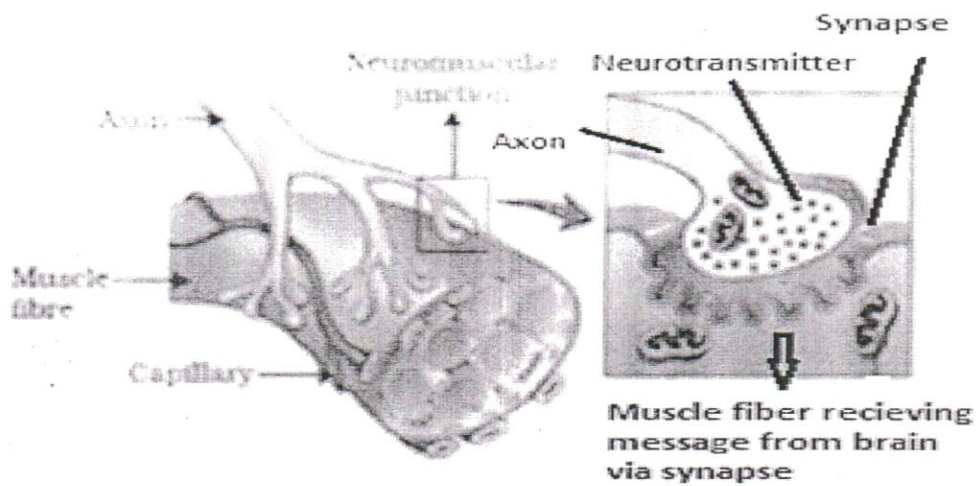
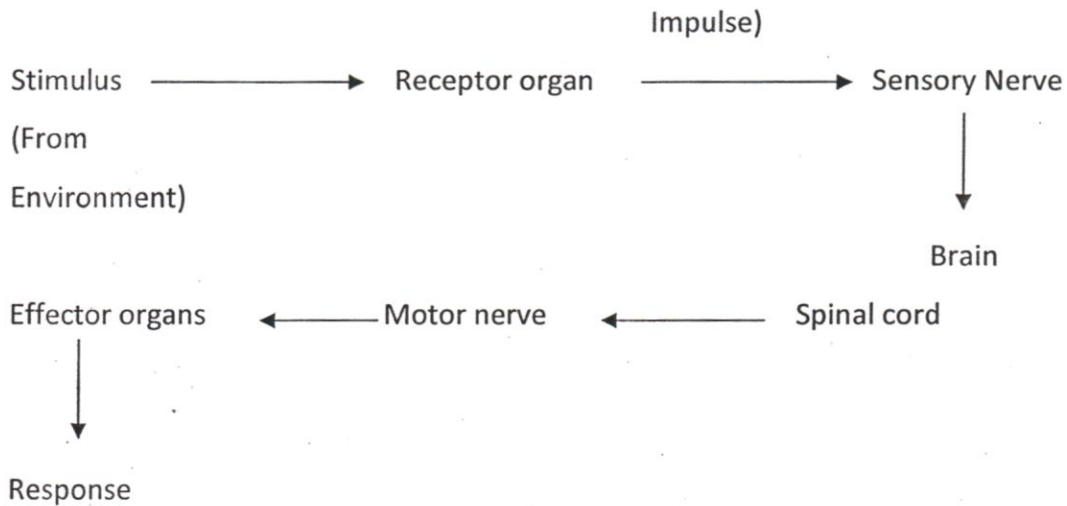

Fig: showing synapse at neuromuscular junction (junction of neuron and skeleton muscle) which control movement.



Reflex action: - It is a quick , automatic response to the change in environment (stimulus) that involves only spinal cord. Reflex action occurs within fraction of seconds.

We say 'I pulled my hand back from the flame reflexly'. What exactly do we mean?

- A common idea is that we do something without thinking about it or very quickly.
- An important question is that how long will it take us to think all this?

For example: When we accidentally touch the hot iron, we pull our hand automatically. This reaction does not involve the brain. In this heat of iron causes thermoreceptor to produce impulse which moves along sensory neuron to spinal cord. Inside spinal cord it travels to interneuron's than to motor neurons and

The components of reflex arc are:

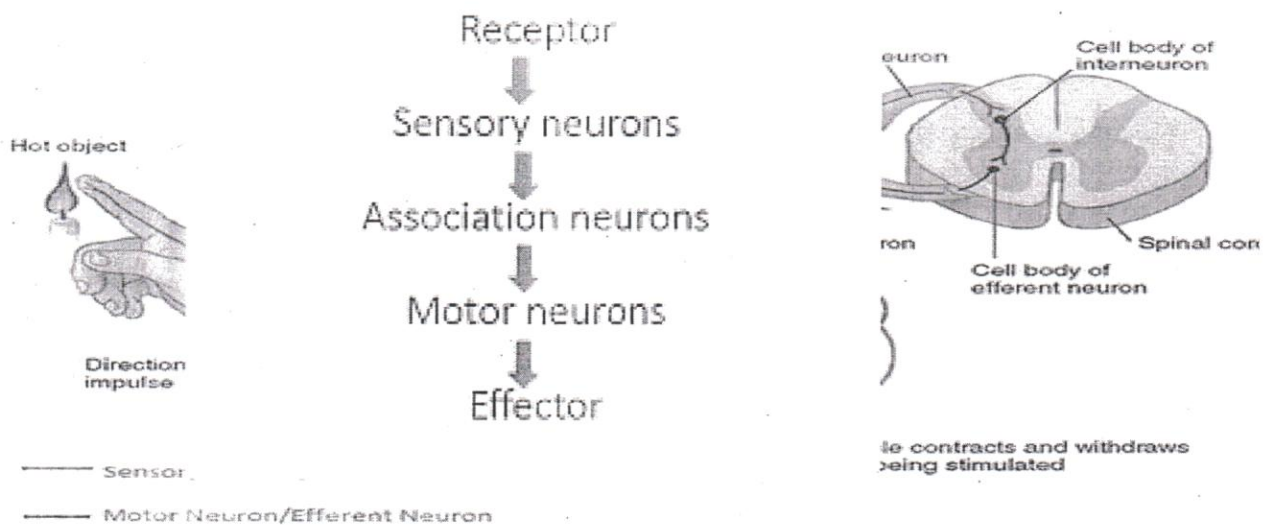

finally reaches the muscles and causes it to contract and pull hand our hand. This reaction occurs in milli seconds.

Control and coordination by hormones

The endocrine system is a system of ductless glands that release chemicals (hormones) into the blood to regulate body functions

- A **hormone** is a chemical messenger that is transported via the bloodstream to act on distant target cells
- Hormones are *specific* and will only activate cells or tissues that possess the appropriate target receptor
- The endocrine system is slower to initiate, but has a more prolonged response when compared to the nervous system

- Major endocrine glands include the pancreas, adrenal gland, thyroid gland, pineal gland and the gonads (ovaries and testes)
- The hypothalamus and pituitary gland are neuroendocrine glands and function to link the nervous and endocrine systems
- Some organs may also secrete hormones despite not being endocrine glands (e.g. adipose tissue secretes leptin)

Hypothalamus

The hypothalamus is the section of the brain that links the nervous and endocrine systems in order to maintain homeostasis

- It receives information from nerves throughout the body and other parts of the brain and initiates endocrine responses
- The pituitary gland is often referred to as the 'master gland', as it controls the secretion of a number of other endocrine glands

ENDOCRINE GLANDS

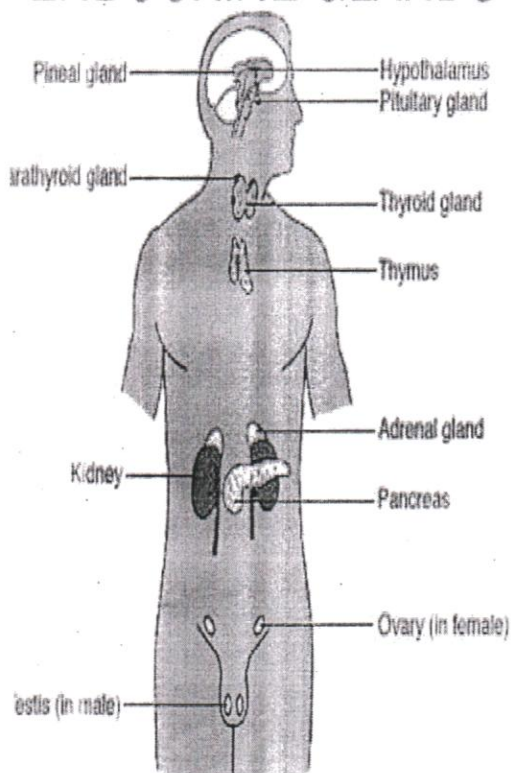

Gland	Hormone	Target Organ	Function
Pineal gland	melatonin	many	biological
Pituitary gland	FSH / LH	ovaries	menstrua
	ADH	kidneys	osmoregu
	growth hormone	many	growth & c
	oxytocin	uterus	birth contr
	prolactin	breast tissue	milk produ
Thyroid gland	thyroxin	liver	metabolic
Adrenal glands	adrenaline	many	fight or fl
	cortisol	many	anti-stre
Pancreas	insulin / glucagon	liver	blood sugar
Ovaries	estrogen / progesterone	uterus	menstrual
Testes	testosterone	many	male charact

- **Learning outcomes**

- 1. **What are neurons?**
 2. **What are receptors?**
 3. **What are receptors for light and sound?**
 4. **What are hormones?**
 5. **What is control and coordination?**
 6. **What is reflex action?**
 7. **What is difference between walking and reflex action?**
 8. **How can you Justify that, nervous system and endocrine system together perform function of control and coordination.?**
 9. **Name the part of brain which controls posture and balance of the body.**
 10. **How is brain prevented from injury and shocks?**

अधिगम स्थिति का निर्माण

कक्षा – दसवीं

विषय – विज्ञान

इकाई – धातु तथा अधातु

विषयवस्तु – धातुओं की क्रियाशीलता तथा क्रियाशीलता क्रम

मुख्य शब्द – विस्थापन प्रतिक्रिया, धातु लवण विलयन, आक्सीकरण, अपचयन।

अधिगम संकल्पना – धातुओं की क्रियाशीलता उसके आक्सीकरण तथा अपचयन की प्रकृति पर निर्भर करती है। धातु जिनके आक्सीकरण की प्रवृत्ति अधिक होगी वह अन्य धातु को उनके लवण से विस्थापित कर देता है।

अधिगम उद्देश्य – विद्यार्थी निम्न अधिगम को प्राप्त करेंगे।

- क्रियाशील तथा कम क्रियाशील धातुओं के बीच अन्तर।
- क्रियाशीलता को धातुओं द्वारा दर्शाये गये प्रतिक्रियाओं के साथ सम्बन्धित करना।
- क्रियाशीलता को आक्सीकरण तथा अपचयन के साथ सहसम्बन्धित करना।
- धातुओं को उनके क्रियाशीलता के बढ़ते क्रम या घटते क्रम में व्यवस्थित करना।

प्रक्रिया कौशल – वर्गीकरण, अवलोकन, निष्कर्ष व्याख्या, विवेक, संचार, तार्किक सोच, जटिल सोच।

अधिगम संसाधन – सोडियम, पोटेशियम, एल्युमिनियम, आयरन, जिंक, मैग्नेशियम, तनु HCl, कॉपर सल्फेट, जिंक सल्फेट, आयरन सल्फेट, परखनली, थर्मामीटर, डेनियल सेल।

मुक्तांत खोज का अवसर – विद्यार्थी कक्षा 8 एवं 9 में धातु तथा अधातु के सामान्य गुणों के बारे में पढ़ चुके हैं। कक्षा 9 में वे धातु तथा अधातु के कुछ सामान्य प्रतिक्रियाओं के बारे में भी पढ़ चुके हैं। यहाँ विद्यार्थियों को कुछ खास धातुओं के क्रियाशीलता की तुलनात्मक अध्ययन का अवसर प्राप्त होगा तथा वे उन्हें उनके क्रियाशीलता के बढ़ते या घटते क्रम में भी व्यवस्थित कर पायेंगे। उन्हें धातुओं की क्रियाशीलता को उनके आक्सीकरण तथा अपचयन प्रवृत्ति से जोड़ने का अवसर प्राप्त होगा।

अधिगम स्थिति का निर्माण –

संलग्न – पहले भाग में शिक्षक विद्यार्थियों के ध्यान को सन्दर्भ के तरफ मोड़ता है।

शिक्षक— आप में से कितने लोग अखबार में NH_4NO_3 के बारे में पढ़ा है? (विद्यार्थी सोचने लगते हैं तथा बाद में प्रतिउत्तर देते हैं।)

विद्यार्थी – महोदय, हमने अखबार में पढ़ा है कि हैदराबाद के बम ब्लास्ट में जो विस्फोटक प्रयोग में लाया गया था उसमें NH_4NO_3 का इस्तेमाल हुआ।

शिक्षक – बहुत अच्छा। क्या आपने सोचा कि विस्फोटक बनाने में केवल NH_4NO_3 का ही प्रयोग क्यों होता है? जबकि दूसरे नाइट्रेट यथा जिंक नाइट्रेट, कॉपर नाइट्रेट आदि का नहीं।

विद्यार्थी – महोदय, NH_4NO_3 अन्य नाइट्रेट की तुलना में अधिक क्रियाशील होता है।

शिक्षक – अच्छा अब हम एक सरल गतिविधि करेंगे। मेरे सहायता के लिए दो विद्यार्थी चाहिए। (दो विद्यार्थी A और B सामने आते हैं)

गतिविधि – दो परखनली लें तथा उनमें आधा पानी भर लें। एक में सोडियम का छोटा टुकड़ा जो कि केरोसिन तेल में रखा होता है, डालें तथा दूसरी परखनली में एल्युमिनियम का छोटा टुकड़ा डालें।

शिक्षक – मदद करने वाले विद्यार्थियों को धन्यवाद। आप लोगों ने क्या देखा।

विद्यार्थी C – महोदय, सोडियम प्रतिक्रिया के दौरान अत्याधिक विस्फोटक है जबकि एल्युमिनियम जल से प्रतिक्रिया कर ही नहीं रहा।

शिक्षक – बहुत अच्छा। अब मैं आपको कुछ धातु दूंगा। आपको इन धातुओं को उनके क्रियाशीलता के घटते क्रम में सजाना होगा। आप समूह में कार्य कर सकते हैं। मैं सदैव आपके साथ हूँ।

अन्वेषण – कक्षा के छात्र तीन समूहों में विभाजित हो जाते हैं। वे अपनी समस्याओं को एक-दूसरे से साझा करते हैं। प्रत्येक समूह अपना प्रयोग तैयार करता है तथा उन्हें क्रियान्वित करता है। शिक्षक सोडियम को पानी में डालने के पूर्व उसे कागज़ में लपेटने की सलाह देते हैं।

व्याख्या/वर्णन/प्रस्तुति – प्रत्येक समूह अपने द्वारा किये गये कार्य की प्रस्तुति अपने कक्षा के समक्ष करते हैं।

प्रथम समूह – सोडियम, आयरन, जिंक तथा कॉपर के तुलना में अधिक क्रियाशील है। लेकिन हम आयरन, जिंक तथा कॉपर की क्रियाशीलता की तुलना नहीं कर पाये।

शिक्षक – ठीक है। आप लोग ठंडे जल के साथ-साथ गर्म जल में भी जाँच सकते हैं। देखिये दूसरे समूह ने क्या पाया।

द्वितीय समूह – महोदय, हम लोगों ने क्रियाशीलता की जाँच तनु HCl के साथ की है। हमने देखा कि जिंक तथा आयरन को तनु HCl में डालने पर एक गैस निकलती है। परन्तु कॉपर के साथ ऐसी कोई गैस नहीं निकलती।

शिक्षक – आपका निष्कर्ष क्या है?

द्वितीय समूह – चूंकि सोडियम जल के साथ विस्फोटक प्रतिक्रिया करता है, तो वह सबसे अधिक क्रियाशील है। जिंक तथा आयरन जल से तो प्रतिक्रिया नहीं कर पाते परन्तु तनु HCl से प्रतिक्रिया करते हैं। अतः जिंक तथा आयरन कॉपर से अधिक प्रतिक्रियाशील होंगे।

शिक्षक – बहुत अच्छा, पर हम आयरन तथा जिंक के प्रतिक्रियाशीलता की तुलना कैसे करेंगे?

द्वितीय समूह – हमने इसके बारे में तो सोचा ही नहीं।

शिक्षक – इन धातुओं को परखनली के तनु HCl में डालने के बाद तापक्रम नोट करना चाहिये। अब देखते हैं तृतीय समूह को। इन्होंने क्रियाशीलता जानने के लिए क्या तकनीक अपनायी है।

तृतीय समूह – महोदय, धातुओं का विस्थापन प्रवृत्ति उनके धातु लवणों से पढ़ा है। जिंक आयरन को आयरन सल्फेट से विस्थापित कर पाता है जो जिंक को आयरन सल्फेट में डालने पर उसके हरे रंग के विलुप्त होने से देखा जाता है। ठीक इसी प्रकार आयरन कापर को कापर सल्फेट से विस्थापित कर पाता है।

शिक्षक – बहुत अच्छा। अब आपको समूह में कार्य करने का फल मिल रहा है। क्या अब आप इन धातुओं को उनके क्रियाशीलता के घटते क्रम में सजा सकते हैं?

विद्यार्थी P – एक विद्यार्थी सामने आता है तथा धातुओं की क्रियाशीलता का सही क्रम ब्लैकबोर्ड में लिख देता है।

सविस्तार –

शिक्षक – हमने यहाँ कुछ ही धातुओं की क्रियाशीलता की तुलना की है। क्या आप इस तरीके को और विस्तार दे सकते हैं जिससे और भी धातुओं की क्रियाशीलता की तुलना की जा सके।

विद्यार्थी – हाँ महोदय। परन्तु इसके लिये हमें इन धातुओं का धातु लवण चाहिये।

शिक्षक – एक धातु का दूसरे धातु को उसके धातु लवण विलयन से विस्थापन का आप सही कारण क्या समझते हैं। कोई उत्तर नहीं।

शिक्षक – क्या आप आक्सीकरण तथा अपचयन के बारे में जानते हैं?

विद्यार्थी – जी महोदय आक्सीकरण में आक्सीजन का योग होता है तथा अपचयन में हाइड्रोजन का योग होता है।

शिक्षक – ठीक है। परन्तु आक्सीकरण तथा अपचयन को इलेक्ट्रान की प्राप्ति या हानि के रूप में भी समझा जा सकता है। इलेक्ट्रान का क्षय या बाहर निकलना आक्सीकरण तथा प्राप्ति अपचयन कहलाता है। आपके प्रयोग में जिंक द्वारा इलेक्ट्रान त्यागने की प्रवृत्ति कॉपर से अधिक होती है। इसीलिये जब जिंक को कॉपर सल्फेट में डाला जाता है तो जिंक, जिंक आयन के रूप में आक्सीकृत हो जाता है। दूसरी ओर कॉपर आयन इलेक्ट्रान प्राप्त करके कॉपर के रूप में अपचयित हो जाता है। अब आप इस तकनीक को दूसरे प्रतिक्रियाओं के साथ भी लागू कर सकते हैं। आप इस तरीके को डेनीयल सेल में होने वाली प्रतिक्रिया पर भी लागू कर सकते हैं।

मूल्यांकन – सम्पूर्ण प्रक्रिया में शिक्षक लगातार विद्यार्थियों के क्रियाकलापों का मूल्यांकन करते रहते हैं। निम्नानुसार मूल्यांकन हेतु निम्न मानदंडों का निर्धारण किया जा सकता है।

- i. प्रयोग करने की क्षमता
- ii. निष्कर्ष निकालने की क्षमता
- iii. व्याख्या करने की क्षमता
- iv. तर्क करने की क्षमता
- v. प्रस्तुतिकरण की क्षमता
- vi. समूह में कार्य करने की क्षमता
- vii. विश्लेषण करने की क्षमता
- viii. प्रबंधन कौशल

समूह कार्य को उपरोक्तानुसार मापने के अलावा विद्यार्थियों को कुछेक रोचक प्रश्न भी किये जा सकते हैं। उदाहरण स्वरूप कॉपर तनु H_2SO_4 से प्रतिक्रिया नहीं करता पर सान्द्र H_2SO_4 प्रतिक्रिया करता है। क्यों?

Learning Physics by Smart phone

Mr. Lokendra Singh Chauhan,
Regional Institute of Education, Bhopal (M.P.)

1.Introduction :-

A smart phone is not smart, only a smart user and app makes it smart . The processor of present phones is much better than that of first manned mission to moon. High memory storage, strong processor, bigger screen, brilliant colour display, large mega pixel camera , blue tooth connectivity , internet , and large number of mobile Apps contributed from all over the world make it a power full teaching learning tool . The idea itself surprises that how a mobile can be used as a learning aid. Whereas on the other hand students are forced to keep aloof themselves from the mobile. People consider it as a menace. But every coin has two sides. I am presenting few applications of smart phone in teaching learning. My focus is more on use of it as a versatile all in one instrument. Users are left to themselves to explore further uses of smart phone.

Role of Smart phone as a laboratory Tool :-

As mentioned in the preceding section , **apps +sensors = tool box**

So first of all lets make it clear that what a sensor is? Sensor is a device which sense physical parameters which can be interpreted by processor. There can be large number of sensors like

- Accelerometer
- Gyro sensor
- Light sensor
- Magnetic sensor
- Temperature sensor
- Pressure sensor
- Humidity sensor

And the list is long, generally ordinary smart phone are equipped with first four sensors mentioned in the list above. These sensors will sense the concerned Physical parameters and inbuilt hardware of the Smart phone converts these parameters into useful digital signal. So now smart phone will act like a data

logger. For example a person is measuring temperature by the help of thermometers, now he/ she will require some time say atleast few seconds to take two consecutive readings , there are process which are too fast for human eye to catch them so by ordinary resources we are limited extremely and the other problem is that one require a large number of such instruments. So this is generally unaffordable to most of the school labs, even if some data is captured than one required to interperate graphically or statistically, still if such instruments are available still there is problems of accessibility to the students can't use them freely and since aim of the given experiment is highly specific so exploration part is highly missing. To overcome such problems smart phone is for our rescue.

Getting started :-

Generally internet connection is not required but yes initially it is required to download mobile apps. But once apps are downloaded than through blue tooth these apps can be transferred to other users also, free of cost. All types of smart phone are use full but I am presenting the use of android smart phone.

So first of all we need to open "GOOGLE PLAY STORE "since it is safer to use. Now it will show as options of Apps, books, movies, Games .

We need to select Apps. Once it is opened there is a search option, there we can search for required Apps. We can get review of the particular App of our interest and apart from it, star rating is also provided so it will help us to download the proper App. The curious users can explore the App and can use it. But all the Apps may not be useful to a user. In fact it depends upon the compatatibility of one`s smart phone. So first of

All we should know all the functionality of our smart phone.

Know your Smart phone :-

To do so the method is very simple. First of all we need to download an App called phone tester nothing special about this App, in fact there are large number of such App but I used this particular one. Once installed, open it and it will provide information about your smart phone under various heads first one is sensor status, after opening it, it will gives us idea about various sensors by which our phone is blessed with, so accordingly we can choose Apps.

Graphical Display :-

Generally the data collected by the phone sensor is displayed graphically one can see the variation of particular parameter along x, y, and z, axes. Now the users should also know about the orientation of these orthogonal axes generally z axes is perpendicular to the plane of smart phone, y axes along the longer dimension (length) of the phone and x axis along the breadth of the phone. ~

Useful Apps and their utility :-

It will not be possible to elaborate the use of all the mentioned App but more common use is mentioned here and once installed the user himself / herself is left to explore it and a good way to learn through constructivist approach .

(1) Vernier Caliper App.

By the help of it one can learn the use of vernier caliper.

(2) smart tools

it is an app which has multiple use like speed measurement (network is required) 2D spirit level, magnetic Compass, magnetometer and many more.

(3) AR- oscilloscope

It is an audio oscilloscope by the help of which we can see sound signal graphically.

(4) FFT spectrum analyser

It helps us to study frequency vs intensity variation of sound
Signal

(5) bismark bs spectrum

By the help it we can measure frequency of audio signal.

(6) sound meter

Help to measure intensity of sound.

(7) Lab4physics

By the help of this App one can make their own distance vs. time graph, but internet connection is required.

(8) Curve Fitter

Helps to graph the collected data and even determines the equation also.

(9) Star chart

I call it the flying heaven of astronomy, a very good app to explore the celestial dome.

(10) Physics tool box sensor suite

This shows shows graphical variation of acceleration, angular speed, magnetic field etc. The user has option of change in scale also.

(11) Long Exposure Camera

We can get trajectory of a moving object and it has got numerous applications in physics and mathematics.

(12) **Frequency Sound Generator**

This can be used as a multiple frequency generator offering sinusoidal, triangular and square waveform.

(13) Algodoo

It is an interactive user friendly interactive platform used for creating simulations based on geometrical optics, mechanics and mathematics. It is very useful in the construction of the knowledge. This is not a mobile application but a freeware.

To develop an inexpensive and innovative video based analysis (VBA) using Tracker[#] a free ware for mechanics experiment

Mr. Lokendra Singh Chauhan
Assistant Professor (Physics)
Regional Institute of Education
Bhopal

INTRODUCTION

In classroom or at home we can make some videos related with daily life situations and analyse the phenomenon shown in those videos using the software Tracker. Such type of analysis using videos is known as video based analysis.

Today, Video Based Analysis (VBA) is one of the teaching methods widely used in different fields that help in effective teaching and learning process.

We have verified some laws of mechanics can be verified and determine some constants using Tracker software.

GENERAL OBJECTIVE

1. To develop data interpretation ability
2. To develop graphical interpretation ability
3. To study given problem of mechanics

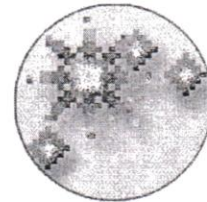

INFORMATION ABOUT TRACKER

Tracker¹ is a free video analysis and modelling tool built on the Open Source Physics (OSP) Java framework. It is designed to be used in physics education.

Tracker video modelling is a powerful way to combine videos with computer modelling.

Tracker requires Java 1.6 or higher.

Tracker Features

Tracking:

- Manual and automated object tracking with position, velocity and acceleration overlays and data.
- Centre of mass tracks.
- Interactive graphical vectors and vector sums.
- RGB line profiles at any angle, time-dependent RGB regions.

Modelling:

- Model Builder creates kinematic and dynamic models of point mass particles and two-body systems.
- External models animate and overlay multi-point data from separate modeling programs such as spreadsheets.
- Model overlays are automatically synchronized and scaled to the video for direct visual comparison with

Subjects

Education Practices
Curriculum Development
Laboratory
Instructional Material Design
Technology
Computers
Multimedia
General Physics
General
Measurement/Units

Levels

Lower Undergraduate
High School
Upper Undergraduate

Resource Types

Instructional Material
Activity
Interactive Simulation
Laboratory
Model
Tool
Software
Audio/Visual
Movie/Animation

Intended Users

Learners
Educators

Formats**METHODOLOGY**

First we identified some daily life problems/situations like

- Freely falling body
- Two body system attached with a pulley
- Friction between two bodies

Performed the activities in somewhat ideal conditions, recorded and analysed using Tracker :



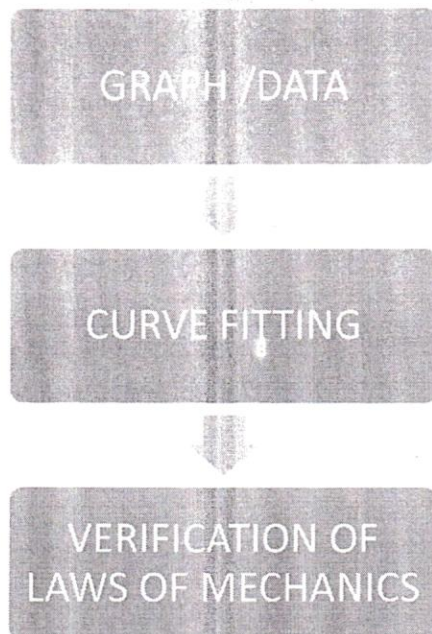

ACTIVITY 1

- **FREE FALL**

Specific Objective

1. To verify the value of acceleration due to gravity (g) of freely falling body on earth using Tracker.
2. To verify the following equations of motion:
 - a) $v = u + gt$
 - b) $h = ut + \frac{1}{2}gt^2$

(where symbols have their usual meaning)

Materials Required

- Object (Ball)
- Camera, stand
- Scale (for calibration)

Theory

Free fall is the motion of any body where gravity is the only force acting upon it.

Moving Down

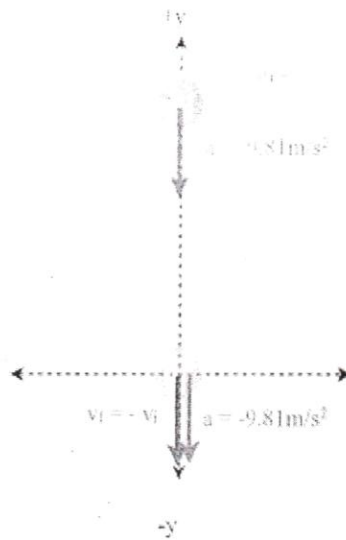

Fig.1

Equations of motion

In mathematical physics, **equations of motion** are equations that describe the behaviour of a physical system in terms of its motion as a function.

The three equations of motion are:

$$v = u + at$$

$$s = ut + \frac{1}{2}at^2$$

$$v^2 - u^2 = 2as$$

Analysis using Tracker

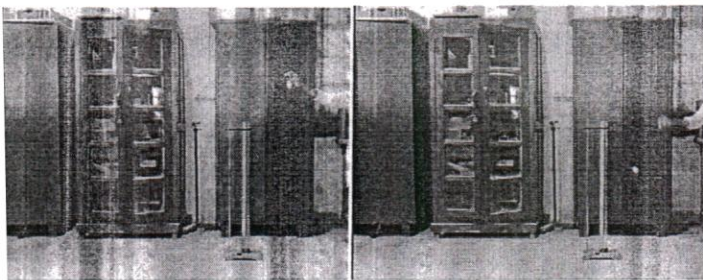
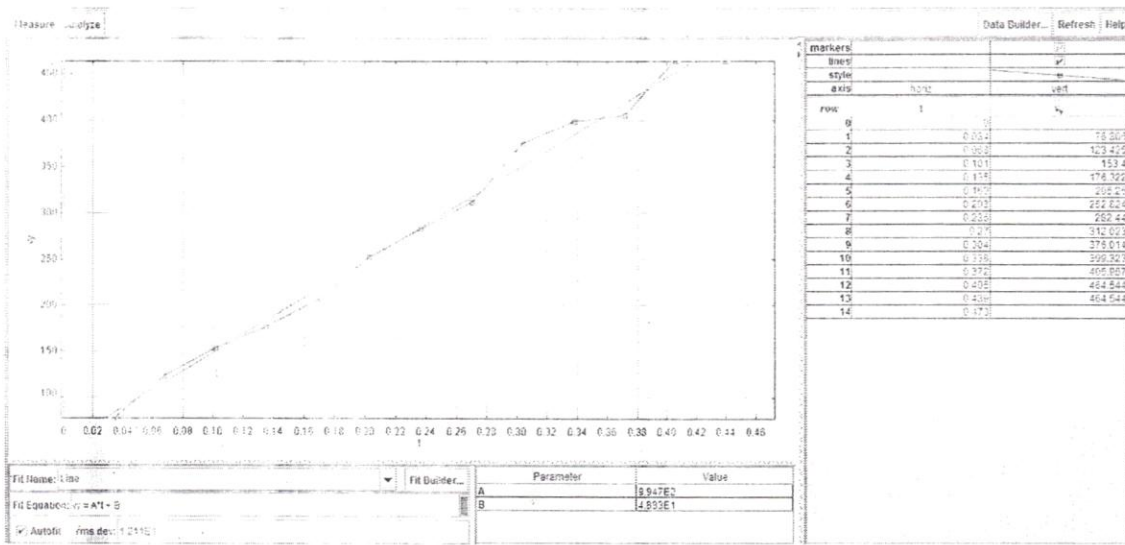

Fig. 2

Fig. 3

- For first equation of motion

$$v = u + gt \quad (\text{here, } u = 0)$$



Graph 1

Curve between velocity (v) and time (t) is a straight line.

And the value of $A (=g) = 9.947E2$

Result

Clearly, graph satisfies the first equation of motion $v = u + gt$

And acceleration due to gravity of freely falling body (ball) on earth is 994.7 cm/sec^2 .

Theoretical value of $g = 980 \text{ cm/sec}^2$.

So error = -1.43%

- For second equation of motion

$$h = ut + \frac{1}{2}gt^2$$

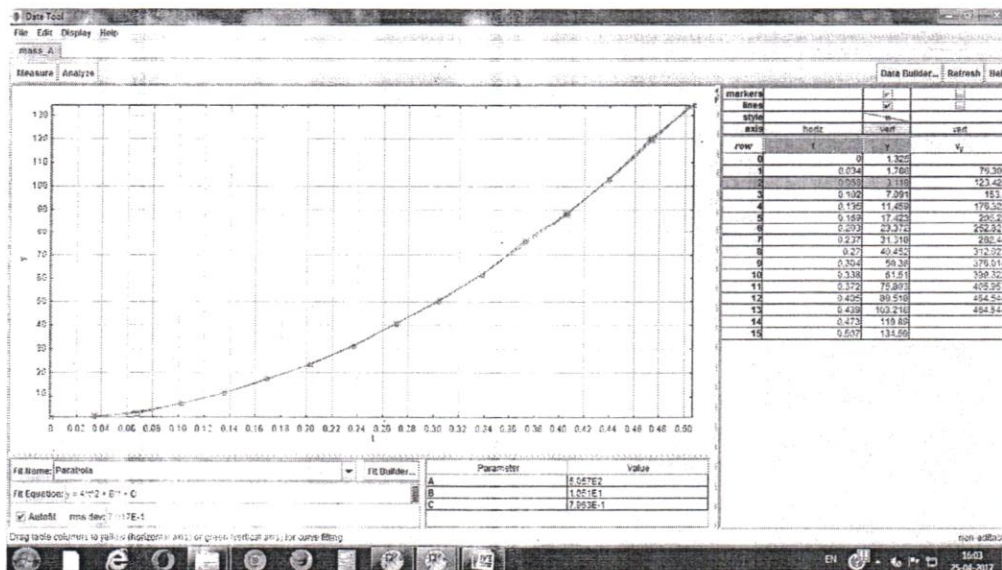

The graph between y (h) and t is a parabola.

$A = 5.05E2$, $B = 1.051E1$

ACTIVITY 2

• ATWOOD MACHINE

Specific Objective

To determine the acceleration of the mass in the string of Atwood machine using Tracker.

Materials Required

Thread, stand, pulley, two masses, scale, weighing machine.

Theory

Frictionless case, neglecting pulley mass

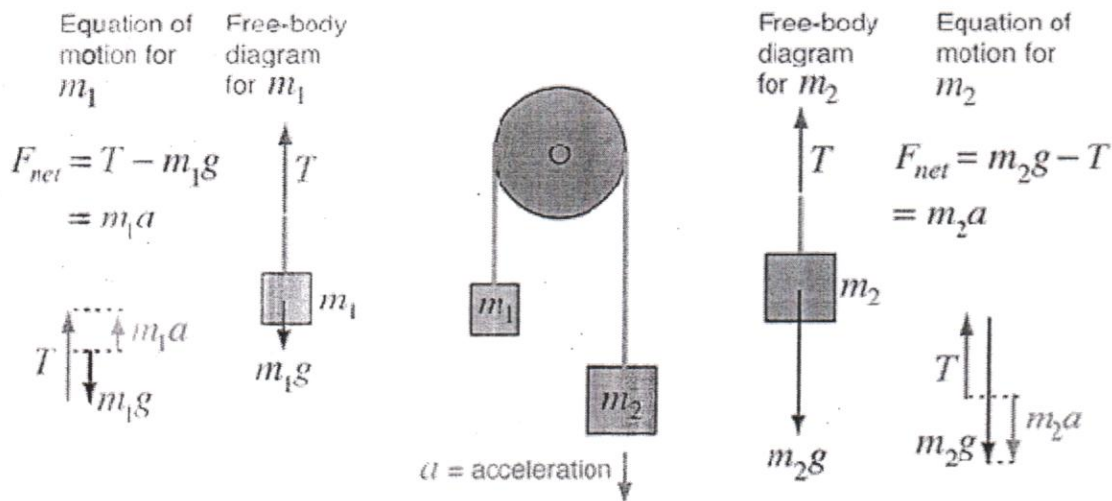

For this idealized case the tension T is the same on both sides of the pulley. The acceleration a is the same for both masses. Solving for T gives:

$$T = m_1g + m_1a$$

Substituting T into the equation for m_2 gives

$$m_2g - m_1g - m_1a = m_2a$$

The equation of motion for the two-mass system is then:

$$(m_2 - m_1)g = (m_1 + m_2)a \quad \text{or} \quad a = \frac{(m_2 - m_1)g}{(m_1 + m_2)}$$

Analysis using Tracker

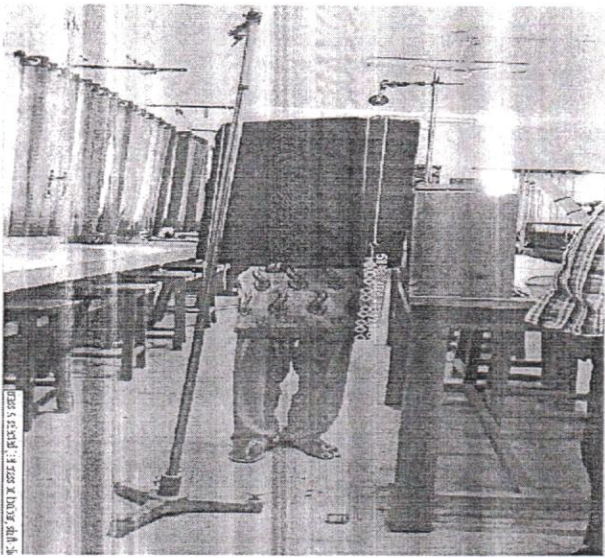

- $m_1 = 230.846 \text{ gm}$
 - $m_2 = 200.228 \text{ gm}$

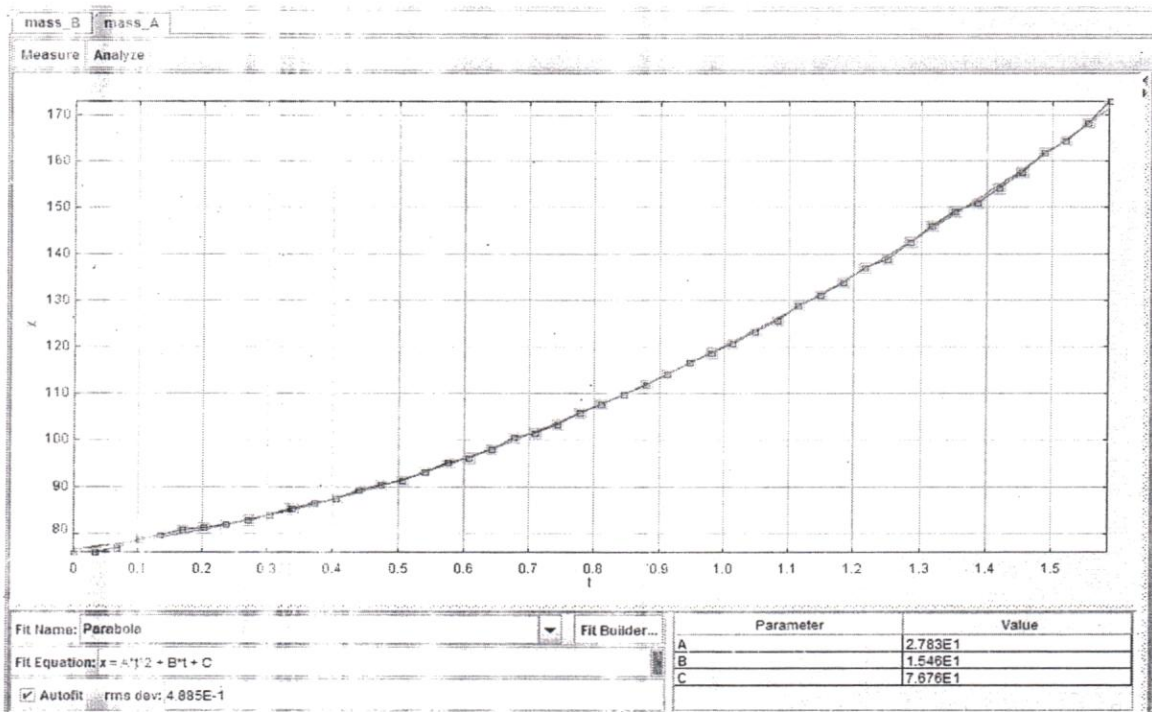

Graph between x and t is a parabola where

$$A = 2.783E1$$

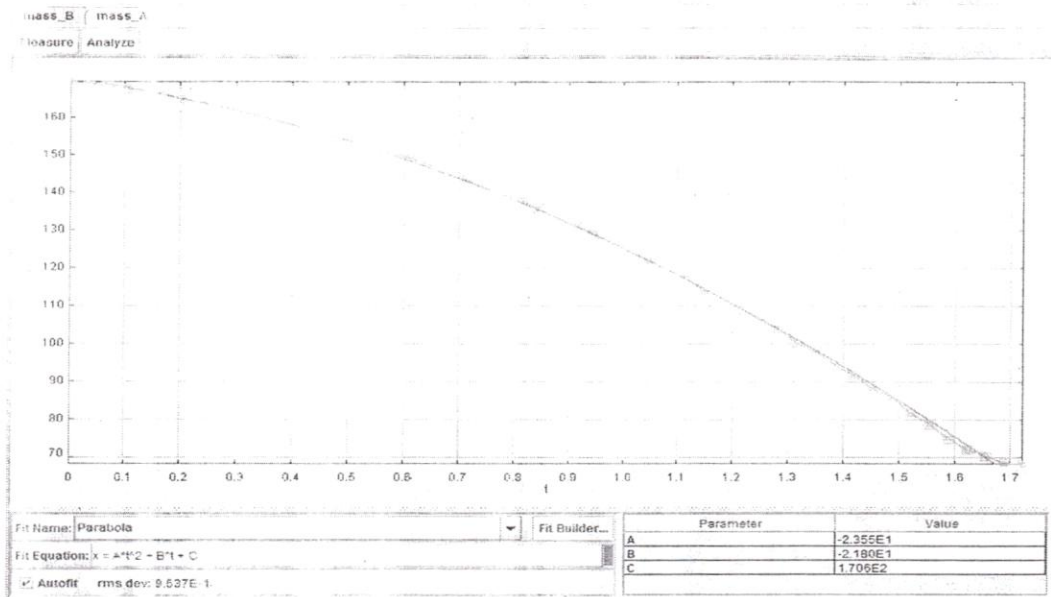

Graph between x and t is a parabola where

$$A = 2.355E1$$

Calculation

Theoretically - From $a = \frac{(m_2 - m_1)}{(m_1 + m_2)} g$

$$a = 73.81 \text{ cm/sec}^2$$

Experimentally - From graph 1 $a_1 = 2A = 55.6 \text{ cm/sec}^2$

From graph 2 $a_2 = 2A = 47.0 \text{ cm/sec}^2$

$$a_{\text{avg}} = 51.38 \text{ cm/sec}^2$$

So,

$$\text{Error} = 30.38\%$$

ACTIVITY 3

• COEFFICIENT OF RESTITUTION

Specific Objective

To determine the coefficient of restitution of tennis ball using Tracker.

Material Required

- Tennis ball
- Scale

Theory

The coefficient of restitution can be seen as the measure of energy transferred during a collision.

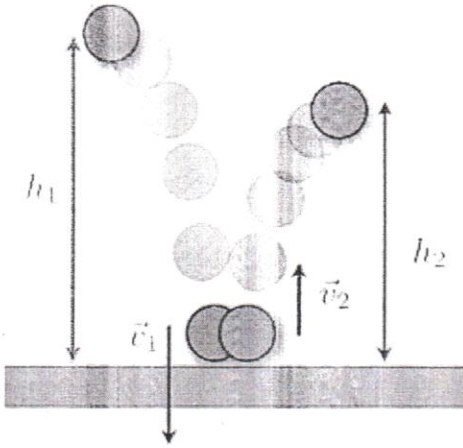

The equation to calculate the coefficient of restitution for an object dropped to the ground is:

$$CoR = \sqrt{\frac{\text{bounce_height}}{\text{drop_height}}}$$

Analysis using tracker

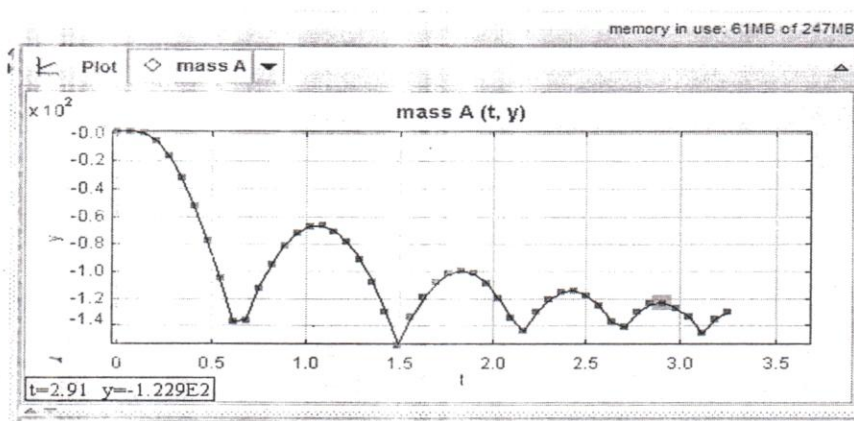
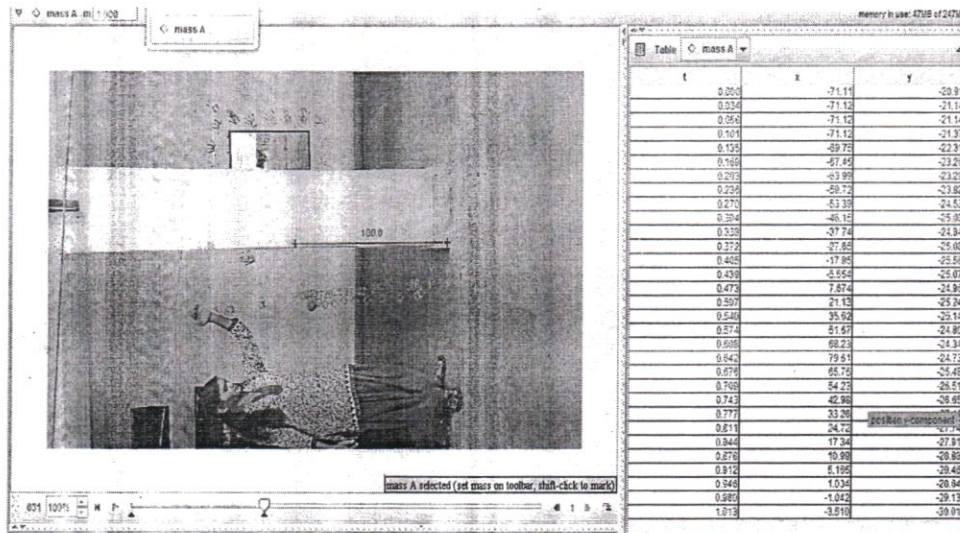

Graph is between height (y) and time (t)

Calculation

Here,

$h_1 = 150 \text{ cm}$, $h_2 = 81 \text{ cm}$, $h_3 = 49 \text{ cm}$,

$h_4 = 34 \text{ cm}$, $h_5 = 25 \text{ cm}$, $h_6 = 18 \text{ cm}$

And,

$$\text{CoR} = \sqrt{\frac{\text{bounce_height}}{\text{drop_height}}}$$

So,

$\text{CoR}_1 = 0.735$, $\text{CoR}_2 = 0.775$, $\text{CoR}_3 = 0.833$

$\text{CoR}_4 = 0.857$, $\text{CoR}_5 = 0.849$

Thus,

$$\text{CoR}_{\text{avg}} = 0.81$$

ACTIVITY- 4

- COEFFICIENT OF KINETIC FRICTION

Specific Objective

In a two body system attached in a horizontal pulley to determine (using Tracker)

- the acceleration
- the coefficient of kinetic friction between glass and wooden block.

Material Required

- Spirit level
- Pulley
- Thread
- Weight box
- Scale
- Glass table
- Wooden box.

Theory

Free-body diagram for mass m_1

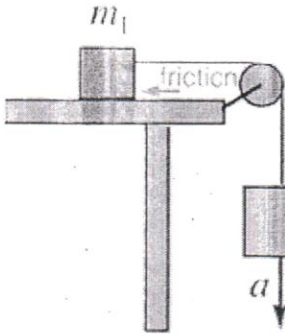
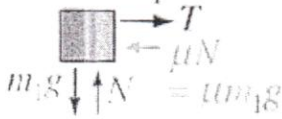

Free-body diagram for mass m_2

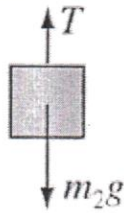

Down is chosen as positive.

Applying Newton's Second Law to the two masses:

$$\text{For } m_2 : m_2g - T = m_2a$$

$$\text{For } m_1 : T - \mu m_1g = m_1a$$

Substituting the expression for T:

$$m_2g - m_1a - \mu m_1g = m_2a$$

$$m_2g = (m_1 + m_2)a + \mu m_1g$$

Solving for acceleration:

$$a = \frac{m_2g - \mu m_1g}{m_1 + m_2}$$

The implication of this expression is that the weight of m_2 minus the frictional resistance provides the net force to accelerate the total mass $m_1 + m_2$

Analysis using Tracker

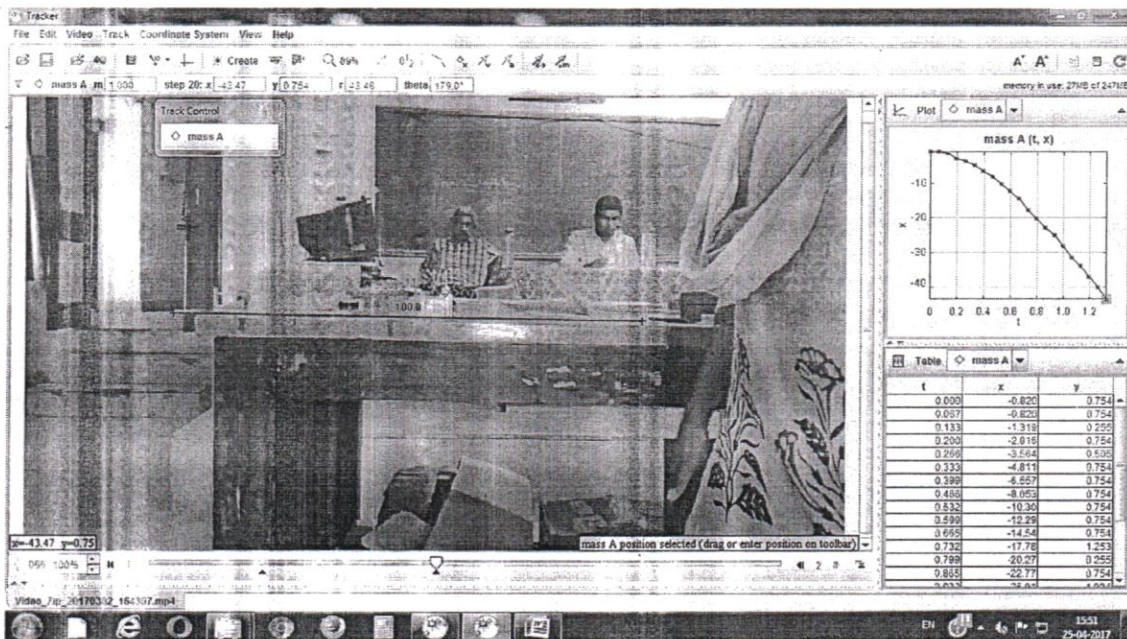

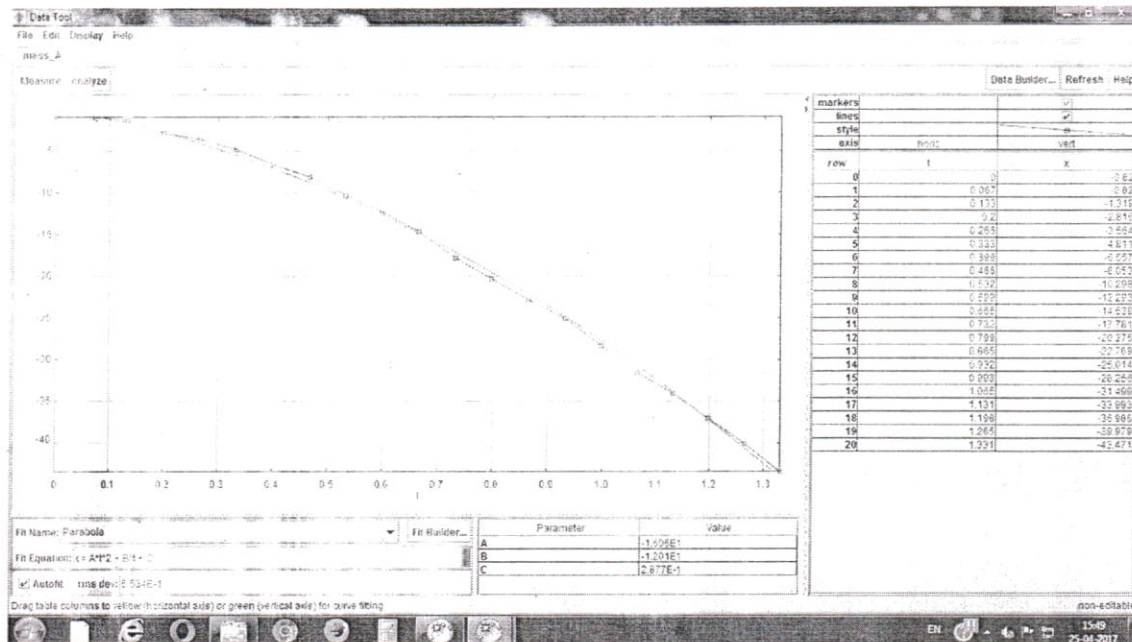

Graph between x and t is parabola

Where,

$$A = 1.605E1$$

So,

$$a = 2A = 32.1 \text{ cm/sec}^2$$

Calculation

Here,

$$m_1 = 200 \text{ gm,}$$

$$m_2 = 109.02 \text{ gm}$$

And,

Coefficient of kinetic friction,

$$\mu_k = \left[m_2 - a \frac{(m_1 + m_2)}{g} \right] \frac{1}{m_1} = 0.49$$

Result

- Acceleration of two body system is 32.1 cm/sec^2 .
- Coefficient of kinetic friction between glass and wooden block is 0.49.

General Precautions

1. Camera should be static.
2. Calibrating scale and experimental set up should be in same vertical plane.
3. Appropriate background should be chosen.
4. Calibration scale, axis, origin and point mass should be chosen carefully.

CONCLUSION

By performing the above mentioned activities we can say that any daily life situation/problem can be easily and accurately analysed from which laws of physics can be verified.

Advantages of using Tracker

- Gives accurate results
- Shows the deviation between standard and obtained data
- Graph between different parameters can be easily obtained
- With minimum input data it gives maximum output

- Easy to use
- It promotes effective learning
- Saves time
- Creative and interesting

Scope

Tracker is a highly useful software which has got great utility in various field of physics . we have used it to verify the laws of mechanics but it can also be used in

Optics

To verify Malus law, Snells law, fraunhoffer diffraction, spectroscopy ,etc.

- Other areas of **mechanics**
 - Projectile motion
 - Stokes law
 - Rotational motion of bodies
 - Simple harmonic motion , etc.

REFERENCE

www.physlets.org

www.physicsclassroom.com

www.hyperphysics.phy-astr.gsu.edu

https://en.wikipedia.org/wiki/Equations_of_motion

<https://www.physicsforums.com> › Physics › General Physics

iopscience.iop.org/article/10.1088/1757-899X/36/1/012038/meta

isjos.org/JoP/vol1/Papers/JoPv1i1-2Tennis.pdf

www.engineeringtoolbox.com/friction-coefficients-d_778.html

www.physlink.com/reference/frictioncoefficients.cfm

Handling of Numerical Data

Prof. I.P.Agrawal

Ex Professor NCERT

Problems Related to Mole Concept and pH

This is the difficulty or the need put forth by the teacher. Let us take this in two parts, first mole concept problems and then problems related to pH.

Appropriate Material to Comprehend the Idea of Mole Concept and Dealing with Numerical Data related to Mole Concept.

While transacting the idea of mole, the first thing that needs be highlighted is that when chemical reactions occur, the number of species participating in a reaction is of prime importance to us. Further mass has no direct significance for the reactions, it may find mention in an indirect way. For example, consider the reaction:-



It is our experience that if we start the reaction by taking 1 g of each of the reacting substance which here is iron and sulphur, then it is found that some sulphur has remained unreacted here. Now as per the reaction need, it is clear that an atom of iron reacts with an atom of sulphur to produce one molecule of iron sulphide. It, therefore, means that if some sulphur is found to be unreacted it is because of the fact that 1g of sulphur has more atoms contained in it compared to 1g of iron. At this stage it may be convenient for you now to answer the following questions.

- (i) **Consider the reaction:-** $\text{Zn(s)} + \text{I}_2\text{(s)} \longrightarrow \text{ZnI}_2$ wherein the reaction is carried out in ethanol as iodine is soluble in ethanol easily compared to water, then why it is so that if carry out the reaction by taking 1g of each of zinc and iodine, then some Zn is left out unreacted here.
- (ii) Further for the reaction: $\text{NaCl(aq)} + \text{AgNO}_3\text{(aq)} \longrightarrow \text{AgCl} + \text{NaNO}_3\text{(aq)}$ if the reaction is carried out by taking 1g each of NaCl and AgNO₃, why after the completion of reaction some NaCl is left out unreacted.

After analyzing you may find the same cause for the two problems put forth here that it is because of inequality in their number though the mass is equal for the reacting species in each case. Case should also be taken of the fact that it is not always the situation that only one species of one reacting substance reacts with one species of the other. For example for the simple reaction for the burning of methane.

$\text{CH}_4\text{(g)} + 2\text{O}_2\text{(g)} \longrightarrow \text{CO}_2\text{(g)} + 2\text{H}_2\text{O(l)}$, careful glance at the equation suggests as that now for combustion of a molecule of CH₄, we this time need two molecules of O₂ and further for the reaction.

$\text{C}_3\text{H}_8\text{(g)} + 5\text{O}_2\text{(g)} \longrightarrow 3\text{CO}_2\text{(g)} + 4\text{H}_2\text{O(l)}$, the situations again changes and this time for combustion of one molecule of hydrocarbon C₃H₈, we need five molecules of O₂. The teacher should impress upon the student that you always need to consider a balanced chemical reaction to make a rationale meaning.

Another very striking point that the teacher needs to keep in mind is that in the idea of mole concept we make a connection between MICROSCOPIC quantities and MACROSCOPIC quantities. Atoms, molecules, ions (which collectively we refer to as species in chemistry) are too extremely small entities to be handled. Here we come across with a very challenging situation and this is when reactions occur, number of species interacting with one another is important for us and our problem is that we cannot count these species as we can apples,

oranges, eggs etc. To tackle the situation we correlate this number with molar mass of the substance, which we can conveniently handle and which is a macroscopic quantity, and number of atoms, molecules and ions are microscopic entities.

One mole of the substance which is its molecular mass expressed in grams, always contains a fixed number of species and it is 6.022×10^{23} . Thus

32g of sulphur has in it 6.022×10^{23} atoms

56g of iron has in it 6.022×10^{23} atoms of Fe

65g of Zinc has in it 6.022×10^{23} atoms of Zn

585g of sodium chloride has 6.022×10^{23} species of NaCl in it.

170g of silver nitrate has 6.022×10^{23} species of AgNO_3 in it.

and finally

254g of iodine has 6.022×10^{23} molecules of I_2 contained in it.

It may now be worthwhile to settle as to why 1g sulphur has more atoms in it compared to 1g of iron. If Δn is the difference then you would appreciate it is

$$\Delta n = \left[\frac{1}{32} \text{ Sulphur atoms in 1g} - \frac{1}{56} \text{ Iron atoms in 1g} \right]$$

Handling of Numerical Data Related to Mole Concept

Let us now deal with this situation keeping in mind three aspects:-

- (i) Mole primarily is a number
- (ii) The number is related to molar mass of the species under consideration.
- (iii) In dealing with numerical data balanced chemical equations only is the guiding pillar. We may do it with the help of following simple problems.

Problem-1

If a glass contains 360g of water liquid in it, then how many water molecules are there in it, given that atomic mass of hydrogen is unity and that of oxygen is sixteen?

Solutions:

Step-1 Expressing formula for water and it is H₂O.

Step-2 Compute molar mass and express in grams. It is $1 \times 2 + 16 = 18\text{g}$

Step-3 Ascertain number of moles of water in 360g of water

If n is the number of moles of water then $n = \frac{360}{18} = 20$

Remember numbers of moles = Total Mass/Molar Mass

Step-4 Ascertain number of H₂O molecules.

As 1 mole has 6.022×10^{23} molecules \therefore Total H₂O molecules present in the glass = $20 \times 6.022 \times 10^{23} = 12.044 \times 10^{24} \neq 1.2044 \times 10^{25}$ (The purpose of the problem is to give a deepen insight to the learner to appreciate the correlation between microscopic quantities and Macroscopic quantities).

Problem-2

Consider the reaction:- $\text{CaCO}_3(\text{S}) \xrightarrow{\text{Hea}} \text{CaO}(\text{S}) + \text{CO}_2(\text{g})$

If 10g of calcium carbonate is fully ignited then what mass of CaO and how many molecules of CO₂ are formed? Given molar mass CaCO₃ = 100, CaO = 56, CO₂ = 44 Each g mole.

Solution:

Step-1 Ascertain number of moles of CaCO₃ present in 10g of CaCO₃, it is $n = \frac{10}{100} = 0.1$, where n indicates number of moles of CaCO₃.

Step-2 Ascertain the number of moles of each substance produced.

Fortunately, the correlation factor is 1:1:1, therefore number of moles of CaO formed = 0.1

Step-3 Conversion of this mole figure into mass

It is $0.1 \times 56 = 5.6\text{g}$

Step-4 Ascertain moles of CO₂ formed. As stated this also is 0.1

Step-5 Conversion of moles of CO₂ into molecules

$$\begin{aligned}\therefore \text{number of molecules of CO}_2 \text{ produced} &= 0.1 \times 6.022 \times 10^{23} \\ &= 6.022 \times 10^{22}\end{aligned}$$

From pedagogy point of views always deal with the situation in smaller steps, as it helps to get clarification about the target.

Problem-3:

Consider the reactions:- $\text{CH}_4(\text{g}) + 2\text{O}_2(\text{g}) \longrightarrow \text{CO}_2(\text{g}) + 2\text{H}_2\text{O}(\text{l})$

If a cylinder of methane contains 1.6kg of methane, then how many moles of O₂, how many molecules and what mass of oxygen is required to fully ignite the given methane? (Given molar mass CH₄ = 16g mol⁻¹ and that of O₂ = 32g mol⁻¹)

Step-1 Ascertain the number of moles of CH₄ given.

$$n = \frac{1.6 \times 1000}{16} = 100$$

Where n is the number of moles of CH₄ present in the cylinder.

Step-2 Establish an appropriate correlation between CH₄ and O₂. As per balanced equation this 1:2.

Step-3 Ascertain number of moles of O₂ required, This is 100 x 2 = 200

Step-4 Ascertain number of molecules of O₂ formed,

$$\text{This is } 2 \times 100 \times 6.022 \times 10^{23} = 2 \times 6.022 \times 10^{25} = 12 \times 6.022 \times 10^{25}$$

(Appreciate 100 is macroscopic and 2 x 6.022 x 10²⁵ is microscopic and molecules are microscopic in nature.)

Step-5 Ascertain mass of O₂ needed

As we need 200 moles of O₂ and molar mass of O₂ expressed in grams is 32g mol⁻¹, therefore, mass of O₂ needed = 200 x 32 = 6.4 x 10³ grams = 6.4 kg.

Problem-4 Consider the reaction:



given that:

$$\text{Molar Mass NH}_3 = 17\text{g mol}^{-1}$$

$$\text{Molar Mass CO}_2 = 44\text{g mol}^{-1}$$

$$\text{Molar Mass Urea} = 60\text{g mol}^{-1}$$

How many moles of each of the reacting substance would be needed to produce 6 quintals of urea?

Solution:

Step-1 Ascertain number of moles of urea needed.

$$n = \frac{6 \times 100 \times 1000}{60} = 10^4$$

(Where n is the number of moles of urea needed to be formed)

Step-2 Correlate urea moles with carbon dioxide moles.

For this the correlation factor is 1:1 therefore, we need 10^4 moles of CO_2 .

Step-3 Correlate urea moles with ammonia moles. This time the correlation factor is 2:1, that is for each urea mole we need two moles of NH_3 .

Step-4 Ascertain total moles of NH_3 required.

$$\eta_{\text{NH}_3} = 2 \times 10^4. \text{ (Where } \eta_{\text{NH}_3} \text{ is the number of moles of ammonia required)}$$

Problems Related to pH Appropriate Material

Here teacher should emphasize that pH is a scale only. This scale we use to express the potentiality of any aqueous solution with regard to its H^+ ion concentration (which actually is H_3O^+ one in aqueous solution). Another striking point that needs to be overemphasized is that pH scale has its correlation with the

multiple of two ionic concentration of the ions produced by H_2O on ionization namely H^+ ion and OH^- ion. This multiple is designated as K_w for water and is expressed as:

$$K_w = [\text{H}^+][\text{OH}^-]$$

As ionization of water is a function of temperature so K_w will also be functions of temperature. Its value at higher temperature will be more and at lower temperature would be less as increase of temperature favours production of ions at 298K temperature, the value of $K_w = 1.0 \times 10^{-14}$ with appropriate units and to be pre use is $K_w = 1.0 \times 10^{-14}$ (gias^{-1}). Since in neutral water $[\text{H}^+] = [\text{OH}^-]$, therefore at 298K,

$$K_w = [\text{H}^+]^2 = 1.0 \times 10^{-14}$$

[∴ we have replaced $[\text{OH}^-]$ by $[\text{H}^+]$]

$$\therefore [\text{H}^+]^2 = 1.0 \times 10^{-14}$$

$$\therefore [\text{H}^+] = 1.0 \times 10^{-7}$$

$$\therefore \text{pH for neutral water at 298K is } \text{pH} = -\log(1.0 \times 10^{-7})$$

$$= -\log 10^{-7}$$

$$= -(-7) \log 10 = 7$$

So pH of neutral water is 7 so long temperature is 298K and $K_w = 1.0 \times 10^{-14}$. Suppose (It is only supposition for simplicity) at some higher temperature TK, K_w is 1.0×10^{-12} (gias^{-1}), then now pH of neutral water will not be 7 and it would be:

$$[\text{H}^+]^2 = 1.0 \times 10^{-12}$$

$$\therefore [\text{H}^+] = 1.0 \times 10^{-6}$$

$$\therefore \text{pH} = -\log(1.0 \times 10^{-6})$$

$$= -(-6) \log 10 = 6$$

With pH = 6 water still is neutral because $[\text{H}^+] = 1.0 \times 10^{-6}$ and also $[\text{OH}^-] = 1.0 \times 10^{-6}$ and the two are still equal.

This is a very important point therefore, needs to be overemphasized that pH scale is related to K_w value for water, which is turn in related to temperature.

Dealing with problems related to pH problem

Calculate the pH of 10^{-2} M HCl Solution

Solution:

Step-1 Write ionization for HCl

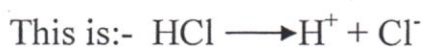

This equation gives as the idea that whatever is the molar concentration of HCl, same is the molar conc. of $[\text{H}^+]$ and it is 10^{-2} M

Step-2 Ascertain pH of the solution

$$\text{pH} = - \log [\text{H}^+] \text{ and here}$$

$$\text{pH} = - \log [10^{-2}] = - (-2) \log 10 = 2$$

$$\text{Therefore pH of } 10^{-2}\text{M HCl} = 2$$

Problem-2 What shall be the pH of 0.005M H_2SO_4 solution?

Solution:

Step-1 Write ionization for H_2SO_4

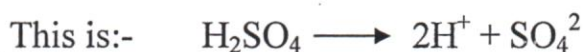

Step-2 Ascertain $[\text{H}^+]$

As 1 mole of H_2SO_4 produces 2 moles of H^+ ions, therefore $[\text{H}^+]$ concentration would be $2 \times 0.005 = 2 \times 5 \times 10^{-3} = 10^{-2}$

Step-3 Ascertain pH of the solution

$$\text{pH} = - \log [10^{-2}] = - (-2) \log 10 = 2$$

Problem-3

What is the pH of a 10^{-2} M NaOH solution?

Solution:

Step-1 Write ionization for NaOH



This indicates 1:1 relationship between NaOH and OH⁻ ions

Step-2 Ascertain [OH⁻] Concentration

Since NaOH conc is 10⁻²M, therefore, evidently [OH⁻] = 10⁻²M

Step-3 Ascertain [H⁺] conc

$$\text{As } [\text{H}^+] [\text{OH}^-] = 1.0 \times 10^{-14}$$

$$\text{and further } [\text{OH}^-] = 1.0 \times 10^{-2}$$

$$\therefore [\text{H}^+] = \frac{1.0 \times 10^{-14}}{1.0 \times 10^{-2}} = 1.0 \times 10^{-12} \text{M}$$

Step-4 Ascertain pH

$$\text{Since } \text{pH} = - [\log \text{H}^+] = - \log 10^{-12} = - (-12) \log 10 = 12$$

So pH of the solution is 12

Teacher should consciously impress upon the students that if [OH⁻] ion conc is known, to ascertain [H⁺], we have to take help of relation:

$$[\text{H}^+] [\text{OH}^-] = 1.0 \times 10^{-14}$$

(If nothing is indicated that means to assume that this Kw value is 1.0x10⁻¹⁴)

Problem: Calculate the pH of 10⁻²M CH₃COOH solution.

This problem is purposely given to only bring home the fact if the acid/alkali is weak electrolyte, are need additional data to affect calculations, which students will study in higher classes only. Acids like CH₃COOH, HCOOH, and HF are weak acids and similarly NH₄OH is a weak alkali.

Magnetic Effects of Electric Current

Kalpana Maski
Assistant Professor, RIE Bhopal

Similar to other effects; electric current also produces magnetic effect. The magnetic effect of electric current is known as electromagnetic effect.

It is observed that when a compass is brought near a current carrying conductor the needle of compass gets deflected because of flow of electricity. This shows that electric current produces a magnetic effect.

Key words:

Magnetic field, electric current, force, electromagnetic induction.

Learning Concepts:

- a. Magnetic Field and Field Lines
- b. Magnetic Effects of Electric Current
- c. Magnetic Field due to a Current through a Straight Conductor
- d. Right-Hand Thumb Rule
- e. Magnetic Field due to a Current through a Circular Loop
- f. Magnetic Field due to a Current in a Solenoid
- g. Electromagnetic Induction

Process Skills: Observation, Interpretation, Critical thinking, Reflective thinking etc.

Learning Resources: various activities for effective learning in a framework.

Creating learning situations:

Magnetic Field and Field Lines

Activity

- Fix a sheet of white paper on a drawing board using some adhesive material.
- Place a bar magnet in the centre of it.
- Sprinkle some iron filings uniformly around the bar magnet. A salt-sprinkler may be used for this purpose.
- Now tap the board gently.
- Iron filings near the bar magnet align themselves along the field lines.

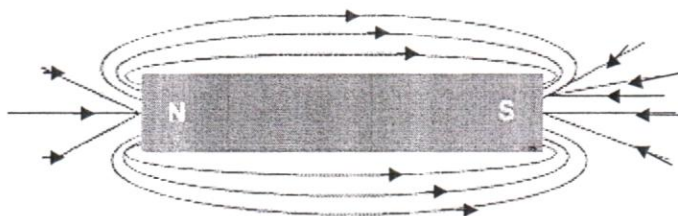

Task1. There is some things wrong in above figure. Figure those out. If you want to contend that it is right provide justification. It is the proper reasoning is important to provide justified reasoning to provide the acceptable answer. There is no correct answer if reasoning is missing.

The magnet exerts its influence in the region surrounding it. Therefore the iron filings experience a force. The force thus exerted makes iron filings to arrange in a pattern. The region surrounding a magnet, in which the force of the magnet can be detected, is said to have a magnetic field. The lines along which the iron filings align themselves represent magnetic field lines.

Magnetic Effects of Electric Current

Magnetic field is a physical manifestation that has both direction and magnitude. The direction of the magnetic field is taken to be the direction in which a north pole of the compass needle tries to orient along it. Therefore it is taken by convention that the field lines emerge from North Pole and merge at the South Pole. Inside the magnet, the direction of field lines is from its south pole to its north pole. Thus the magnetic field lines are closed curves.

CCE

Q. Do you know the method by which you can experience its presence? If yes, by which senses of human body. If no the how do you experience it.

Q. To say closed curves, how will you ensure that its direction is from south to north? Hint: make a hole in the magnet big enough to fit in the compass needle.

Q. How far correct this statement that field lines emerge from North Pole and merge terminate at the South Pole?

The relative strength of the magnetic field is shown by the degree of closeness of the field lines. The field is stronger, that is, the force acting on the pole of another magnet placed is greater where the field lines are crowded. No two field-lines are found to cross each other. If they did, it would mean that at the point of intersection, the compass needle would point towards two directions, which is not possible.

CCE

Q. The crowdedness is relative terms. How will you reduce the number of line of forces emanating from the North Pole? Hint: screening of magnetic field.

Q. If I say I would physically show that the lines of forces cross, how to experiment it? Hint: size of compass needle.

Q. When I say magnetic lines of force are closed curves, how do I justify why the lines of force emerging from centre of the North Pole do not form a closed curve. Similarly these appear to be coming to South Pole from a far off distance? Hint: terminates at nearby pole.

Q. I want to show that South Pole is behaving as North Pole. What should I do? Hint: mathematics people demonstrate that given line segment can be longer or shorter.

Magnetic Field due to a Current through a Straight Conductor

Activity

- Take a long straight copper wire and fix it in vertical plane. You can do it if the wire is put on the table for horizontal plane for record by compass. Large current cells two or three cells of 1.5 V each, and a plug key. Connect all of them in series. Cells in series generally do not work.

CCE

Q. If so Then what to do?

Q. If field is very weak, how would you increase its strength?

- Place the straight wire parallel to and over a compass needle.

CCE

Q. what does this orientation prove. Hint: field lines are circular

- Plug the key in the circuit.
- Observe the direction of deflection of the north pole of the needle. If the current flows from north to south, the north pole of the compass needle would like to move towards the east.

CCE

Q. to show compass needle moves what kind of experiment you propose?

- Exchange the terminals of the cell connections in the circuit. This would result in the change of the direction of current through the copper wire, that is, from south to north.
- Observe the change in the direction of deflection of the needle. You will see that now the needle moves in opposite direction, that is, towards the west. It means that the direction of magnetic field produced by the electric current is also reversed.

Activity

- Take a battery (12 V), a variable resistance (or a rheostat), an ammeter (0–5 A), a plug key, and a long straight thick copper wire.

- Insert the thick wire through the centre, normal to the plane of a rectangular cardboard. Take care that the cardboard is fixed and does not slide up or down.

In the above experiment vary the current in the wire. We find that the deflection in the needle also changes. In fact, if the current is increased, the deflection also increases. It indicates that the magnitude of the magnetic field produced at a given point increases as the current through the wire increases.

Now place the compass at a farther point from the conducting wire. You can see that the deflection in the needle decreases. Thus the magnetic field produced by a given current in the conductor decreases as the distance from it increases.

Right-Hand Thumb Rule

Imagine that you are holding a current-carrying straight conductor in your right hand such that the thumb points towards the direction of current. Then your fingers will wrap around the conductor in the direction of the field lines of the magnetic field. This is known as the right-hand thumb rule.

This rule is also called Maxwell's corkscrew rule. If we consider ourselves driving a corkscrew in the direction of the current, then the direction of the corkscrew is the direction of the magnetic field.

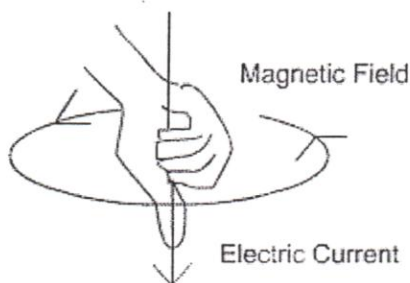

Magnetic Field due to a Current through a Circular Loop

We have so far observed the pattern of the magnetic field lines produced around a current-carrying straight wire. Suppose this straight wire is bent in the form of a circular loop and a current is passed through it. We know that the magnetic field produced by a current-carrying straight wire depends inversely on the distance from it. Similarly at every point of a current-carrying circular loop, the concentric circles representing the magnetic field around it would become of a larger diameter as we move away from the wire. By the time we reach at the centre of the circular loop, the arcs of these big circles would appear as straight lines. Every point on the wire carrying current would give rise to the magnetic field appearing as straight lines at the centre of the loop. By applying the right hand rule, it is easy to check that every section of the wire contributes to the magnetic field lines in the same direction within the loop.

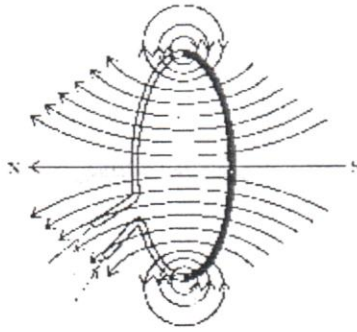

Coutesy: ekshiksha.org.in

CCE

Q. The concentric circles representing the magnetic field around it would become larger and larger as we move away from the wire. The lines of force in the case shown above are not circular. Why?

Q. In the above set up. Can you make for multiple wires set? Or made those wire thicker? Discuss it pros and cones.

We know that the magnetic field produced by a current-carrying wire at a given point depends directly on the current passing through it. Therefore, if there is a circular coil having n turns, the field produced is n times as large as that produced by a single turn. This is because the current in each circular turn has the same direction, and the field due to each turn then just adds up.

Magnetic Field due to a Current in a Solenoid

A coil of many circular turns of insulated copper wire wrapped closely in the shape of a cylinder is called a solenoid. In this case, one end of the solenoid behaves as a magnetic north pole, while the other behaves as the South Pole. The field lines inside the solenoid are in the form of parallel straight lines. This indicates that the magnetic field is the same at all points inside the solenoid. That is, the field is uniform inside the solenoid. A strong magnetic field produced inside a solenoid can be used to magnetise a piece of magnetic material, like soft iron, when placed inside the coil. The magnet so formed is called an electromagnet.

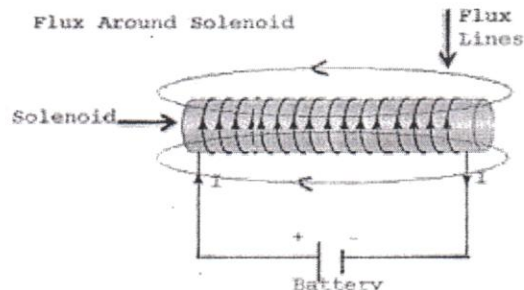

Courtesy: www. mytech-info.com

Force on a Current-Carrying Conductor in a Magnetic Field Activity

- Take a small aluminium rod (of about 5 cm). Using two connecting wires suspend it horizontally from a stand.
- Place a strong horse-shoe magnet in such a way that the rod lies between the two poles with the magnetic field directed upwards. For this put the North Pole of the magnet vertically above and South Pole vertically below the aluminium rod.
- Connect the aluminium rod in series with a battery, a key and a rheostat.
- Now pass a current through the aluminium rod from end B to end A.
- It is observed that the rod is displaced towards the right. You will notice that the rod gets displaced.
- Reverse the direction of current flowing through the rod and observe the direction of its displacement. It is now towards the left.

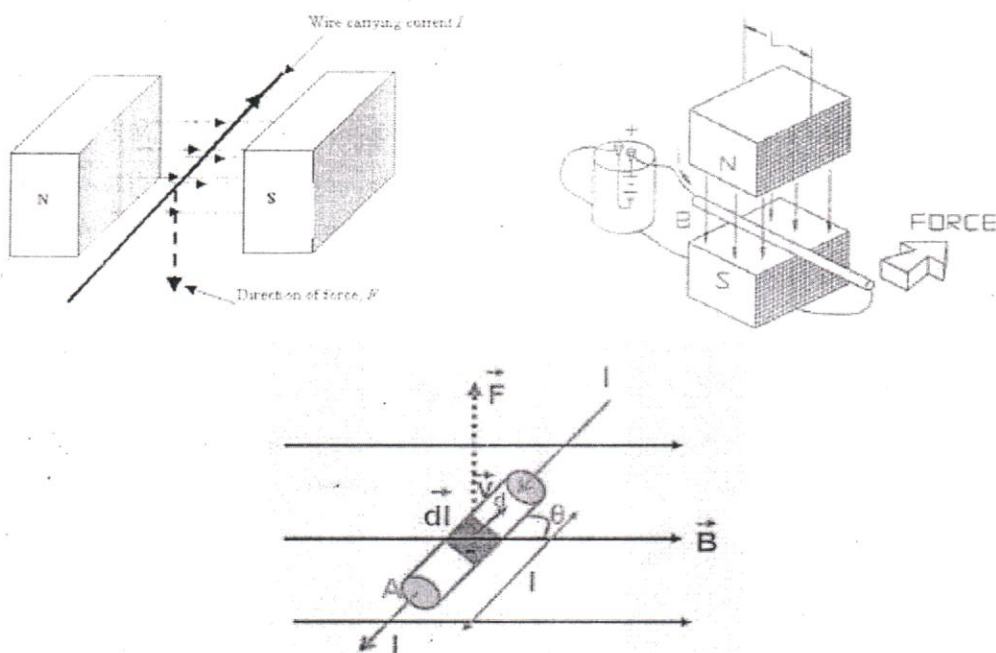

Figures are taken from www.antinine-education.co.uk

A current-carrying rod, experiences a force perpendicular to its length and the magnetic field.

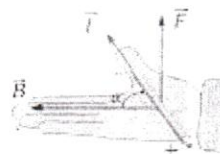

Figure is taken from wikipedia.org

The displacement of the rod in the above activity suggests that a force is exerted on the current-carrying aluminium rod when it is placed in a magnetic field. It also suggests that the direction of force is also reversed when the direction of current through the conductor is

reversed. Now change the direction of field to vertically downwards by interchanging the two poles of the magnet. It is once again observed that the direction of force acting on the current-carrying rod gets reversed. It shows that the direction of the force on the conductor depends upon the direction of current and the direction of the magnetic field. Experiments have shown that the displacement of the rod is largest (or the magnitude of the force is the highest) when the direction of current is at right angles to the direction of the magnetic field. In such a condition we can use a simple rule to find the direction of the force on the conductor.

In the above activity we considered the direction of the current and that of the magnetic field perpendicular to each other and found that the force is perpendicular to both of them. The three directions can be illustrated through a simple rule, called Fleming's left-hand rule. According to this rule, stretch the thumb, forefinger and middle finger of your left hand such that they are mutually perpendicular. If the first finger points in the direction of magnetic field and the second finger in the direction of current, then the thumb will point in the direction of motion or the force acting on the conductor.

Magnetism in Medicine:

When we touch something, our nerves carry an electric impulse to the muscles we need to use. This impulse produces a temporary magnetic field. These fields are very weak and are about one-billionth of the earth's magnetic field. Two main organs in the human body where the magnetic field produced is significant are the heart and the brain. The magnetic field inside the body forms the basis of obtaining the images of different body parts. This is done using a technique called Magnetic Resonance Imaging (MRI). Analysis of these images helps in medical diagnosis.

CCE

Q. Does the blood circulation have any thing to do with magnetic field?

Task 2. Search from literature how much current that can pass through our body with out any damage? Then find out what can be the voltage we can withstand?

Electromagnetic Induction

In 1831, Faraday made an important breakthrough by discovering how a moving magnet can be used to generate electric currents. To observe this effect, let us perform the following activity.

- Take a coil of wire having a large number of turns.
- Connect the ends of the coil to a galvanometer as shown in figure given below.
- Take a strong bar magnet and move its north pole towards one end of the coil.

- There is a momentary deflection in the needle of the galvanometer, say to the right. This indicates the presence of a current in the coil. The deflection becomes zero the moment the motion of the magnet stops.
- Now withdraw the north pole of the magnet away from the coil. Now the galvanometer is deflected toward the left, showing that the current is now set up in the direction opposite to the first.
- Place the magnet stationary at a point near to the coil, keeping its north pole towards the end of the coil. We see that the galvanometer needle deflects toward the right when the coil is moved towards the north pole of the magnet. Similarly the needle moves toward left when the coil is moved away.
- When the coil is kept stationary with respect to the magnet, the deflection of the galvanometer drops to zero.

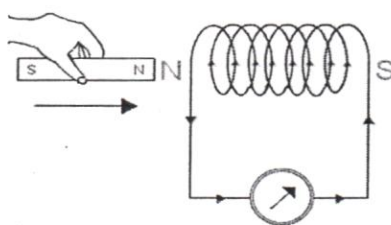

Courtesy: physics.tutorvista.com

Discussion

Moving a magnet towards a coil sets up a current in the coil circuit, as indicated by deflection in the galvanometer. A galvanometer is an instrument that can detect the presence of a current in a circuit. The pointer remains at zero (the centre of the scale) for zero current flowing through it. It can deflect either to the left or to the right of the zero mark depending on the direction of current. You can also check that if you had moved South Pole of the magnet towards the end of the coil, the deflections in the galvanometer would just be opposite to the previous case. When the coil and the magnet are both stationary, there is no deflection in the galvanometer. It is, therefore, clear from this activity that motion of a magnet with respect to the coil produces an induced potential difference, which sets up an induced electric current in the circuit.

Evaluation

1. A coil is kept in a magnetic field. How much current it must generate?
2. Two magnets are kept at a distance d , what action we must take so that they remain there?
3. Will there be any kind of field between them? Discuss.
4. Difference between Fleming's left hand rule and right hand rule? Why so?
When shall you prefer one over the other?

5. We board the train whose bogies are generally of iron. When the train is speeding across the earth's magnetic field what kind of current may generate if possible. Are we harmed by this current? If Yes, Why? If No, why?
6. Trace from history, what are different laws related to electromagnetism?
7. Think of a world without magnetic properties of substances.
8. Explain why two magnetic lines of forces do not intersect.
9. Distinguish between a bar magnet and electromagnet.
10. What is electromagnetic induction? Explain how the movement of a magnet towards or away from a coil carrying a galvanometer produce current?

List of Resource Persons

A. List of External Resource Person

1. Prof. I.P Agrawal : Regional Institute of Education (Retd. Prof.)
2. Prof. V.G. Jadhao : Regional Institute of Education(Retd. Prof.)
3. Prof. Pramod Patil : IEHE , Bhopal
4. Prof. Mukund Bapat : Regional Institute of Education(Retd. Prof.)
5. Prof. Suchitra Banerjee : IEHE , Bhopal
6. Prof. Ajay Bharadwaj : IEHE , Bhopal

B. List of Internal Resource Person

1. Prof. N. Pradhan : Principal , Regional Institute of Education
2. Prof. V.K. Kakaria : Regional Institute of Education
3. Prof. L.K. Tiwary : Regional Institute of Education
4. Prof. Jaydip Mandal : Regional Institute of Education
5. Dr. Chitra Singh : Regional Institute of Education
6. Dr. Kalpana Maski : Regional Institute of Education
7. Dr. N.C. Ojha : Regional Institute of Education
8. Mr. L.S Chouhan : Regional Institute of Education
9. Dr. Shivalika Sarkar: : Regional Institute of Education
(Programme Coordinator)

PHYSICS FEEDBACK

अपसारी एवं अभिसारी प्रकाश घटना के संदर्भ में दिए गए क्रिया कलाप में बाल को काटकर आलपिन लगाने वाले क्रिया कलाप की जगह यदि टार्च का प्रयोग किया जाता तो एक अच्छा उदाहरण होता जिसे बच्चा पहले से जानता है टार्च के अग्रभाग को घुमाकर लाईट को फैलाना एवं एक लिन्दु पर एकत्र करना ये एक अच्छा क्रियाकलाप होता जो वास्तविक में प्रकाश के साथ क्रियाकलाप होता।

अध्याय का नाम:- विद्युतधारा एवं परिपथ

विद्युत धारा की दिशा के संबंध में कठिनाई होती है विद्युत धारा किस दिशा में बह रही है कैसे स्पष्ट करें।

2. विद्युतधारा एवं परिपथ:-

(a) विद्युत घटकों को संकेत के माध्यम से समझाया गया है जिसमें संकेतों की व्याख्या करने में कठिनाई हो सकती है।

. ऊर्जा के स्वरूप एवं स्रोत:-

“ऊर्जा को न ही उत्पन्न किया जा सकता है और न ही नष्ट” इस तथ्य को सिद्ध करने के लिए उचित उदाहरण तथा प्रमाणिक क्रियाकलाप द्वारा समझाना।

अध्याय 12 से:- कक्षा 10 वीं

1. विद्युत चुंबकीय प्रेरण, विद्युत मीटर को नामांकित चित्र से समझाना कठिन है।
2. डायनेमो या विद्युत जनित्र को समझाना।

प्रकाश परावर्तन एवं अपवर्तन समतल सतह से:-

समझाने में कठिनाई

- विषय अनुसार सभी विषय जैसे भौतिक को जीवविज्ञान शिक्षक को पढ़ाने में तथा जीवविज्ञान के शिक्षक से भौतिक या रसायन को समझाने में।
- Physics के derivation को समझाने में
- प्रायोगिक सामग्री को क्लासरूम तक लाने-जाने में समय लगता है, जिससे पाठ्यक्रम पूरा करने में समय लगता है, एवं कठिनाई है।
- विषय-वस्तु ऐसा हो कि क्रियाकलाप से आसानी से जोड़ा जा सके।
- आवश्यकता से अधिक क्रियाकलाप कराने पड़ते हैं। जिससे छात्रों का अध्यापन से ध्यान भटकता है।
- दर्पण के प्रतिबिंब, पूर्ण-आंतरिक परावर्तन, आभासी प्रतिबिंब का बनना को समझाने में कठिनाई।
- परिभाषाएं स्पष्ट नहीं होती हैं एवं उदा. कम हैं।

विद्युत के चुंबकीय प्रभाव

1. वृत्तकार लूप या कुंडली के कारण चुंबकीय क्षेत्र को समझने में।

2. चुंबकीय क्षेत्र में किसी विद्युत धारावाही चालक पर बल को समझने में, परिनालिका के कारण चुंबकीय क्षेत्र को समझने में।
3. इस अध्याय में पाठ्यक्रम को समझने में कठिनाई क्योंकि अवधारणा स्पष्ट नहीं हो पाता है।

ध्वनि-

ध्वनि का संचरण कैसे होता है समझाने में माध्यम अदृश्य?

1. तरंगों को समझने में कठिनाई
अश्रव्य, पराश्रव्य को प्रायोगिक नहीं समझाया
आवृत्ति, आवर्तकाल एवं आयाम को समझाने में कठिनाई।

• ध्वनि:-

ध्वनि का संचरण सैद्धांतिक रूप में पढ़ाया जाता है, परंतु गतिविधियों के रूप में समझाने में कठिनाई होती है। अनुदैर्घ्य एवं अनुप्रस्थ तरंगों को समझाने में कठिनाई। अवश्रव्य एवं पराश्रव्य ध्वनि को प्रायोगिक रूप से नहीं समझाया जा सकता। ध्वनि प्रदूषण एवं उनके हानिकारक प्रभावों को कक्षागत शोर-गुल एवं अनिद्रा के उदाहरण से समझाया जा सकता है। आवृत्ति, आवर्तकाल एवं आयाम को गतिविधियों द्वारा समझाने में कठिनाई।

अध्याय 11 गुरुत्वाकर्षण

कठिन बिंदु:-

1. $F = \frac{Gm_1m_2}{R^2}$

R²

आंकिक प्रश्न हल करने में बच्चों को कठिनाई होती है।

2. मुक्त पतन पढ़ाने में कठिनाई होती है। एक बच्चा बॉल के पृथ्वी से ऊपर किक करता है तो वह ABCDE से होते हुए गिरता है, इस समय बॉल के हवा में ऊपर से नीचे आने के बीच तक बॉल में कौन-कौन से बल कार्य करते हैं, यह समझने में कठिनाई होती है।

3. द्रव्यमान तथा भार में अंतर समझने में कठिनाई होती है जिसे उचित क्रियाकलाप द्वारा समझाया जाना चाहिए।

4. गुरुत्वीय केंद्र पढ़ाने में कठिनाई होती है।

5. गति:- कठिन बिंदु:

- a. चाल और वेग
- b. सूत्र वाले प्रश्नों को समझाने में
- c. गति का ग्राफ बनाने में
- d. वृत्तीय गति को समझाने में
- e. गति के समीकरण समझाने में
- f. एक समान त्वरित गति में वेग समय संबंध

6. बल एवं गति के नियम:-

- a. संतुलित बल असंतुलित बल
- b. गति के नियम समझाने में
- c. रैखिक संवेग
- d. संवेग संरक्षण का नियम

CHEMISTRY FEEDBACK

हाइड्रोकार्बन के व्युत्पन्न

एथेनाल एवं एसिटिक अम्ल की औद्योगिक निर्माण विधि से पहले उसके प्रयोगशाला में निर्माण की विधि, गुण का उल्लेख करते हुए बताया जाता तो बच्चों के लिए सरलता होती एवं विषय अधिक सरल होता सरलता से कठिन की ओर का सिद्धांत लागू होता, यद्यपि औद्योगिक निर्माण की विधि आगे की बड़ी कक्षाओं के लिए लाभकारी है। इसी तरह आलू में वर्धी प्रजनन के साथ यदि विषय वस्तु आलू के बारे में पहले जानकारी जैसे आलू के बारे में पहले जानकारी जैसे आलू एक तना है उसकी आंखें पार्श्व कलिका हैं उसके रूपान्तरण की जानकारी दी जाती तो अधिक रोचक जानकारी बच्चों को प्राप्त होती।

अधातुओं का रसायन-

समझने में कठिनाई

- प्रश्नोत्तर के अभ्यासार्थ प्रश्नों को समझने में कठिनाई होती है।
- क्रियाकलाप के सभी सामग्री नहीं है तो बच्चों को चित्र दिखाकर बताना पड़ता है जैसे ये वुल्फ बोतल है, घिसेल कीप इत्यादि।
- क्रियाकलाप/गतिविधियों को यथार्थ कराने में दिक्कत होती है, क्योंकि उपलब्ध सामग्री पुराना है या नहीं है।
- अध्यायों के नाम:- 4. तत्वों का आवर्ती वर्गीकरण
- तत्वों के आवर्ती गुण:- संयोजकता, परमाणु आकार, आयनन ऊर्जा इलेक्ट्रान बंधुता, विद्युत ऋणता।
Colourful Periodic Table is necessary
- 1. आंकिक प्रश्न के संबंध में कठिनाई।
- कुछ बच्चों का आंकिक प्रश्न के प्रति पूर्वाग्रह को कम करने में कठिनाई।
- 2. अन्य वे प्रश्न जिसमें आपको कठिनाई हो।
- छात्र संख्या अधिक होने पर प्रत्येक बच्चों पर केंद्रित होने में कठिनाई।
- सभी प्रायोगिक आवश्यक उपकरणों की अनुपलब्धता/समय पर अनुपलब्धता और समय का अभाव। छात्रों की संख्या के अनुसार समय का अभाव।

अध्याय का नाम- 17. दैनिक जीवन में रसायन

कठिन बिंदु:-

1. किन अवधारणाओं को समझने में कठिनाई है ?
2. किन अवधारणाओं को समझने में कठिनाई होती है।
- प्रायोगिक कार्य से संबंधित अवधारणाएं जिनके निष्कर्ष किताब में उपलब्ध नहीं है तथा आवश्यक घटक उपलब्ध न हो। उसके निष्कर्ष बिना प्रयोग बताने पर बच्चों की जिज्ञासा बनी रही जाती है।
3. किन अवधारणाओं के लिए गतिविधियों की आवश्यकता है?

नमक का निर्माण
सीमेंट का निर्माण विधि
कांच का उत्पादन

4. कौन सी गतिविधियां करने/कराने में कठिनाई होती है?

Activities which can be easily explained by Direct interaction or education tour

Ex.

सीमेंट निर्माण

Needs factory visit

कांच उत्पादन

5. अन्य वे प्रश्न जिनमें आपको कठिनाई है।
6. प्रायोगिक कार्यों में कठिनाई।

1. अवधारणा (अम्ल, क्षार एवं लवण) कम समय देकर वर्गीकरण के आधार पर दें।
2. अवधारणाओं को समझाने के लिए प्रायोगिक गतिविधियां जो प्रयोगशाला में करना चाहिए।
3. आंकिक प्रश्नों को (पी.एच. गणना हेतु प्रश्नों) का समावेश करें। व्यंजक आवश्यकता है।
4. प्रायोगिक कार्यों में सामग्री की समस्या है।
5. अम्ल वर्षा को चित्र के द्वारा अवधारणा तथा लाभ हानियां।
6. अवधारणाओं को पूर्वज्ञान की कमी के कारण समझाने में कठिनाई।
7. परिभाषा स्पष्ट हो तथा उसे कोष्ठक में होना चाहिए।
8. ज्ञानवर्धक शब्द को अन्डरलाईन दें।
9. प्रश्नों के प्रकार

(a) अति लघुउत्तरीय प्रश्न

(b) लघुउत्तरीय प्रश्न

(c) दीर्घ उत्तरीय प्रश्न

(d) उचित संबंध का समावेश क्रमानुसार किया जाना चाहिए ताकि छात्रों को ब्लूप्रिंट के आधार पर तैयारी करने में सहजता हो।

अध्याय 17 दैनिक जीवन में रसायन (पाठ्य पुस्तक में सिलेबस का बिंदुवार वर्णन हो)।

- रैसिक वर्गीकरण के द्वारा अवधारणा को कम समय में स्पष्ट किया जा सकता है।
- मुख्य शब्द को अलग से डिफाइन करने से अच्छा होता।

सभी बातों को सरल शब्दों से स्पष्ट रूप में प्रदर्शित एवं वर्णित किया गया है।

हाईड्रोकार्बन-

छात्रों को संकेतों व सूत्रों का ज्ञान न होना नामकरण का शुरू के कक्षा में ज्ञान का अभाव हाईड्रोकार्बन की संरचना में बंधों को समझाने परमाणु क्रमांक की समझ में।

- हाईड्रोकार्बन:-

छात्रों का संकेत एवं सूत्रों का ज्ञान नहीं होने से समझाने में कठिनाई होती है। नामकरण 9वीं स्तर के विद्यार्थियों के लिए जटिल कार्य है। हाईड्रोकार्बन की संरचना एवं कार्बन और कार्बन हाईड्रोजन बंधों को संतुलित करने में छात्रों को परेशानी होती है। एल्केन, एल्किन एवं अल्काइन में बंध निरूपण में परेशानी। बांस की तीली एवं प्लास्टिक बाल के द्वारा परमाणु एवं अणु की संरचना व्यक्त किया जा सकता है।

अध्याय- 10 रासायनिक अभिक्रियाएं एवं समीकरण

कठिन बिंदु:-

1. रासायनिक समीकरण के संतुलन में विद्यार्थियों को कठिनाई होती है।

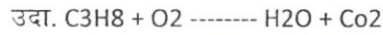

हल करते समय कार्बन तीन करते समय निम्न गलती करते हैं-



2. विस्थापन अभिक्रिया – हम पढ़ते हैं कि अधिक क्रियाशील धातु कम क्रियाशील धातु को विस्थापित करती है।

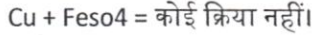

बच्चों को यह समझाना कठिन है कि कौन धातु अधिक क्रियाशील है। इसके लिए विद्युत रासायनिक श्रेणी का ज्ञान आवश्यक है, जो उनके लिए बहुत कठिन है।

3. द्विविस्थापन अभिक्रिया – इसमें धनायनों तथा ऋणायनों का आपस में आदान-प्रदान होता है तथा प्राप्त यौगिक में एक अवक्षेपित होता है तथा दूसरा विलयन में रहता है। बच्चे यह समझ नहीं पाते कि यौगिक किस प्रकार और कितना इलेक्ट्रॉन त्याग या ग्रहण कर आयन बनाते हैं।

4. ऑक्सीकरण तथा अपचयन – अभिक्रिया को अधिक स्पष्टता से समझाने के लिए गतिविधि की आवश्यकता है।

5. ऊष्माशोषी तथा ऊष्माक्षेपी अभिक्रिया को समीकरण में दर्शाने में कठिनाई होती है।

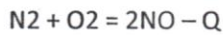
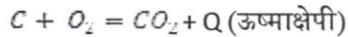

अध्याय 12 कार्य एवं ऊर्जा

1. धनात्मक कार्य एवं ऋणात्मक कार्य को गतिविधि द्वारा समझाने की आवश्यकता है।
2. गतिज ऊर्जा का गणितीय व्यंजक बच्चों को समझाने में कठिनाई होती है।
3. आंकिक प्रश्नों को हल करने में बच्चे किस सूत्र का प्रयोग कर, उसमें कन्फ्यूज रहते हैं।

• छात्र को पूर्व कक्षा में रासायनिक समीकरण का अध्ययन नहीं किए रहते हैं, जिसके कारण सूत्र लिखने की क्रिया में कठिनाई होती है। संयोजकता व सूत्र को पूर्ण रूप से 9वीं स्तर पर विस्तृत नहीं होने के कारण अध्यापन में कठिनाई जबतक ये सब 11, 12 के स्तर पर दिया गया है।

• Atomic Structure की Video C.D. के माध्यम से teaching के लिए प्रदान किया जाए ताकि छात्र/छात्राओं को अच्छे से समझ सकें।

अध्याय 9

1. रासायनिक सूत्र और मोल संकल्पना

आठवीं में बच्चों के तत्व, यौगिक के नाम की जानकारी का अभाव होता है और नवमी में बिना इसकी जानकारी के रासायनिक सूत्र व मोल को नहीं समझ पाते।

अध्याय 8

रासायनिक आबंधन

कक्षा 8 में रासायनिक आबंधन के बारे में पाठ्यपुस्तक में इस विषय के बारे में जानकारी के लिए कोई भी पाठ नहीं है। बच्चों को कम पर रासायनिक प्रक्रिया को सरलतम रूप में समझाया जा सके।

अध्याय 7

छात्र आड़ी काट व खड़ी काट में अंतर नहीं कर पाते व सेक्शन कटिंग में अभ्यास न होने के कारण उन्हें पूर्ण जानकारी नहीं मिल पाती। शालाओं में विज्ञान विषय के लिए उपयुक्त जरूरी उपकरणों या लैब के अभाव के कारण शिक्षकों को विषय पढ़ाने में कठिनाई आती है।

A. परमाणु संरचना-

1. समस्थानिक, परमाणु, समभारिक

कार्बन तत्व के बारे में यह देखा गया है कि कार्बन के कुछ परमाणुओं की दृश्यमान संख्या 12 और कुछ की 14 है। ऐसा कैसे होता है? वास्तव में कार्बन 12 और कार्बन 14 में न्यूट्रानों की संख्या अलग-अलग होती है जहां कार्बन 12 से 6 न्यूट्रान होते हैं वहीं कार्बन 14 से 8 न्यूट्रान होते हैं।

2. प्रयोगिक कार्य में समस्या आता है।

3. बेरी-बेरी योजना

4. अल्फा कण प्रकीर्णन प्रयोग और रदरफोर्ड का परमाणुपाद-

रदरफोर्ड द्वारा प्रस्तुत परमाणु के नाभिकीय मॉडल ने परमाणु में एक छोटे से नाभिक और उसके चारों ओर घूमने वाले इलेक्ट्रान के बारे में बताया इस मॉडल से यह स्पष्ट नहीं होता है कि ये इलेक्ट्रान परमाणु में किस तरह से वितरित हैं। इलेक्ट्रान ऋणावेश होता है।

BIOLOGY FEEDBACK

Evolution

(1) किसी भी अवधारणाओं को समझाने में पाठ्य पुस्तक को सचित्र होना आवश्यक होता है जिसमें चित्र बहुत ही साफ सुथरा और रंगीन होना है। चित्र रंगीन होने के साथ-साथ स्पष्ट हो जिससे छात्रों के मानस पटल पर चित्र स्पष्ट बन सके और उन्हें समझने की आजादी हो।

(2) प्रश्नों का क्रम ब्लूप्रिंट के आधार पर हो जैसे लघु उत्तरीय और दीर्घ उत्तरीय एवं अति लघुउत्तरीय प्रश्नों के समावेश के साथ-साथ उचित संबंध जैसे प्रश्नों का समावेश होना चाहिए।

अध्यायों का नाम- (1) जैविक प्रक्रियाएं: प्रजनन, वृद्धि और परिवर्धन (अध्याय 14)

क्रियाकलापों की अवधि अधिक लंबी होने के कारण तथा पूरी किताबों में क्रियाकलाप बहुत अधिक होने से यह किताब पूरी प्रायोगिक हो गई है। इन प्रयोगों को करने के लिए एक संपूर्ण प्रयोगशाला की आवश्यकता है। जिससे अवधारणाओं को समझाने में आसानी हो सके।

संपूर्ण किताब में चित्र साफ, स्पष्ट तथा Coloured नहीं हैं। यदि हम कोशिका विभाजन तथा प्रजनन संबंधित विषयों पर चर्चा करते हैं तो छात्रों को चित्र स्पष्ट नहीं होने पर समझ/अवधारणाओं के ज्ञान में कमी, आ सकती है।

अध्यायों के नाम:-

1. पारिस्थितिक तंत्र में ऊर्जा का प्रवाह तथा जीव भार के पिरामिड को समझाने में कठिनाई हुई।
2. पारिस्थितिक तंत्र का अर्थ

अध्याय का नाम:- जैविक प्रक्रियाएं, पोषण, परिवहन, श्वसन एवं उत्सर्जन

कठिन बिंदु-

1. पाचन क्या है? परिभाषित नहीं किया गया है।
2. वृक्क में नेफ्रान्स की संरचना बनाया गया है किंतु वृक्क की आन्तरिक संरचना में नेफ्रान्स की स्थिति को नहीं बताया गया है।
3. फेंफड़े का चित्र

अध्याय का नाम:- ऊर्जा के स्वरूप एवं स्रोत

कठिन बिंदु:- भोजन से ऊर्जा हमें कैसे मिलती है ?

जैविक क्रियाएं:- पाचन, परिसंचरण, उत्सर्जन, श्वसन

(a) पाचन की प्रक्रिया Formula के द्वारा ज्यादा बेहतर तरीके से clear किया जा सकता है। उदाहरणार्थ- कार्बोहाइड्रेट, प्रोटीन का पाचन इत्यादि।

(b) परिसंचरण तंत्र:-

क. हृदय परिवहन तथा फेफड़े के बीच संबंध

ख. चित्रों का पूर्ण नामांकन

ग. बिंदुओं का स्पष्टीकरण- द्विलवणीय तथा त्रिलवणीय कपाट का महत्व

(c) उत्सर्जन तंत्र:- वृक्क तथा नेफ्रान के बीच वृक्क के काट की संरचना को स्पष्ट किया जाना चाहिए जिससे वृक्क के भीतर नेफ्रान की स्थिति को बेहतर समझाया जा सके।

4. जैविक प्रक्रियाएं:- नियंत्रण एवं समन्वय

(a) सूचना प्रवाह की प्रक्रिया कठिन है, सुगमतापूर्वक समझाने के लिए सचित्र व्याख्या की आवश्यकता।

हमारा स्वास्थ्य:-

1. स्वास्थ्य क्या है, पूर्ण जानकारी नहीं।
2. संतुलित आहार पढ़ाया जाता है किंतु अर्थ वास्तविक अभाव।
3. रोग के वास्तविक कारणों से अनभिज्ञता
4. स्वच्छता के कार्यक्रमों को सही ढंग से पालन न होना
5. अंधविश्वास मिटाना मुश्किल
 - संक्रामक रोग के प्रति जागरूकता लाना, किंतु मनोरोगों को दूर करने में कठिनाई।
6. सिकल सेल को डिफाइन करने में कठिनाई बच्चा नहीं समझ पाता।
7. संक्रामक व असंक्रामक रोग में अंतर में कठिनाई।
8. एड्स जैसे बीमारी पर खुलकर विचार न रख पाना।
9. पोषटिक अल्सर, सार्स जैसे रोगों को समझाने में।

प्रश्न- मुख्य बिंदु पर प्रश्नों का होना।

10. विभाग तक सीमित

- हमारा स्वास्थ्य:- स्वास्थ्य क्या है? बालक नहीं जानता।

संतुलित आहार पढ़ाया जाता है परंतु पोषण/आहार पुस्तकीय ज्ञान रह जाता है। प्रयोगशाला में गतिविधि द्वारा नहीं समझाया जा सकता, स्वच्छता पर “हस्त प्रक्षालन दिवस कार्यक्रम” से प्रेरणा, संक्रामक रोगों के प्रति जागरूकता लाया जा सकता है। परंतु सामाजिक भ्रांतियां तथा तंत्र-मंत्र एवं मनोरोग को दूर करने में कठिनाई। सर्दी जुकाम, कंजक्टिवाइटिस, टी.बी. इत्यादि पर गतिविधियां आयोजित किया जा सकता है। स्वास्थ्य संबंधी प्रयोग एवं उपचार के साधन एक विभाग तक सीमित होने से गतिविधियों में कठिनाई का होना। पोषटिक आहार, एनीमिया एवं सार्स जैसे रोगों को समझने एवं समझाने में कठिनाई। प्रश्नावली निर्माण में सभी बिंदुओं को सम्मिलित न हो पाना।

- A. जैव विविधता एवं वर्गीकरण
1. वर्गीकरण
 2. नामकरण (वैज्ञानिक नामकरण में)
 3. एककोशिकीय जीव में
 4. बहुकोशिकीय
5. जीवन की मौलिक इकाई कोशिका:-
- a. तरह-तरह की कोशिकाओं का अवलोकन करके समझाने में।
 - b. अंतः झिल्ली तंत्र और कोशिकांगों में अन्तर्संबंध
 - c. कोशिकांगों के नाम याद रखने में।
 - d. अंतः सहजीविता से बने अंग।
 - e. कोशिकांगों के कार्य समझाने में।
 - f. कोशिका झिल्ली का अवलोकन।

REGIONAL INSTITUTE OF EDUCATION, BHOPAL
Department of Extension Education

RELIEVING CERTIFICATE

DEE/RIEB/PAC-16.37/2017-18/

Dated: 12.01.2018

is to certify that the following participants attended a five-day Training programme on *“Training of KGBV and Aavya Vidyalaya teachers of Chhattisgarh in content and pedagogy of science at secondary level”* held from 9th to 13th January, 2018 in this Institute.

Name	Official Address
Ashok Kumar Dadesna	Ekalavya Model Residential Higher secondary School Taregaon (JUNGLE) Bodla Kabirdham (CG)
Dharmraj Verma	Govt. Ekalavya Model Residential Kabirdham (CG)
K.P. Gendle	Ekalavya Model Residential Higher secondary School Taregaon (JUNGLE) Bodla Kabirdham (CG)
Nand Lal Dahnia	Ekalavya Model Residential School Taregaon (JUNGLE) Dist Kabindhane (CG)
Jyoti Shrivastava	Ekalavya Model Residential School Mainpat Surguja Ambikapur CG
Sraddhanjali Gauda	Ekalavya Vidyalaya Hr. Sec School Pandi Dist Korea
Savita Das	Ekalavya Vidyalaya Hr. Sec School Pandi Dist Korea
Saroj Kumar Gupta	Ekalavya Vidyalaya Hr. Sec School Pandi Dist Korea
Virendra Kumar Dewangan	Ekalavya Model Residential School Mainpat Surguja Ambikapur
Najirius Tirkey	Ekalavya Model Residential School Mainpat Surguja Ambikapur
Gyanendra Kumar Dhiwar	Ekalavya Model Residential School Mainpat Surguja CG
Suresh Kumar Soni	Ekalavya A A Vidyalaya Rajnagoan CG
Anit Kumar Chatterjee	Ekalavya Model Residential School Sanna Dist Jashpur CG
Ravi Kumar Banjara	Ekalavya Model Resi Hr. S School Chhote Mudpar Kara Dist Rajgarh CG
Mankamna Prasad Verma	Ekalavya Model Re. H.S.S Shivaprasadnagar Dist Surajapur CG
Tilak Ram Surya	Ekalavya Model Residential H. S. S Chhote mudpar Dist Raigarh CG
Deonarayam Patel	Ekalavya Model Residential Hr. Sec School Chhotemudpar Dist Rajgarh CG
Ritesh Kumar Thawait	Govt. Ekalavya Model Residential School Chhotemudpar Dist Raigarh CG
Gauri Shankar Goarya	Ekalavya Model Residential Higher Sec School Antagarh Dist U.B Kanker CG
Dinesh Kumar Sinha	Ekalavya Model Residential Higher Sec School Antagarh Dist U.B Kanker CG
Nirmal Kumar Behera	Ekalavya Model Residential Higher Sec School Antagarh Dist U.B Kanker CG
Puran Lal Sudhakar	Ekalavya Model Residential School Shivprasadngan Dist Surajpur CG
Rambilas Tirkey	Ekalavya Model Residential School Shivprasadngan Dist Surajpur CG
Dharamrai Ratre	Ekalavya R.G School Jawang Dantewara CG
Kamlesh Kumar Denjare	Ekalavya Model Resi School Karpawand Bastar CG Pin 494222
Shiv Kumar Kanwar	Ekalavya Model Resi K.S.P Katekalyan (Dantewada) CG
Atul Singh	Ekalavya Model Resi Girls Higher Sec School Katekalyan, Dist Dantewada
Mordhvaj Sahu	Ekalavya Model Resi School Kardawana Dist Bastar (CG)
Pyarelal Lahare	Ekalavya Model Resi School Kardawana Dist Bastar (CG)

further certified that they are being relieved in the afternoon of 13th January, 2018 after making payment of advances as per NCERT norms.

HEAD
 Department of Extension Education

Copy to:

1. Persons concerned
2. Head of Institution

Training Programme of KGBV and Eklavya Vidyalaya teachers of Chhattisgarh on content and pedagogy of secondary level
January 09 -13, 2018

Date & Day	9.00-9.30 am	9.30-11.00am		11.00am - 11.15am	11.15am-12.45pm	12.45pm - 2.00 pm	2.00-3.30pm	3.45-5.15pm
09.01.18 Tuesday	Registration	Sound KM		TEA BREAK	Chemical Reactions and Equations IPA	LUNCH BREAK	Force and Motion VGJ	Heredity PP
10.01.18 Wednesday	Feedback	Constructivism approach in teaching learning process NP	11.00am-12.00pm Chemistry in Daily Life CS		12.00-1.15 pm Our Health RG		Electric Current and Circuit MB	Chemical Bonding RS
11.01.18 Thursday	Feedback	Control and Coordination in Plants JM			Conservation of Energy MB		Cell division growth and development in animals SS1	Chem Lab Work RS
12.01.18 Friday	Feedback	Biodiversity SB			Control and Coordination in Animals VK		Metals and Non Metals LKT	Optics LSC
13.01.18 Saturday	Feedback	Multicellular Structure: Tissue AB			Chemical formula and Mole Concept IPA		Phy Lab Work LSC	Gravitation SS

(Valedictory) 5.15pm-5.45pm

Shivalika
8/1/18
Dr. Shivalika Sarkar
Programme Coordinator

1. NP: Prof. Nityanand Pradhan
2. VGJ: Prof. V.G. Jadhao
3. PP: Prof. Pramod Patil
4. MB: Prof. Mukund Bapat
5. AB: Prof. Ajay Bharadwaj
6. VK: Prof. V.K. Kakaria

7. SB: Prof. Suchitra Banerjee
8. JM: Prof. Jaydip Mandal
9. RS: Dr. Rashmi Sharma
10. LKT: Prof. L.K. Tiwary
11. RG: Dr. Ruchi Gautam
12. CS: Dr. Chitra Singh

13. IPA: Prof. I.P Agrawal
14. KM: Dr. Kalpana Maski
15. LSC: Mr. L.S Chouhan
16. SS2 : Dr. Shivalika Sarkar
17. SS1: Dr. Sudhi Shrivastava

8/1/18



One day workshop for need assessment at SCERT Raipur on 10/10/2017